



OPERATOR'S MANUAL

MODEL #100380
REAR TINE TILLER



REGISTER YOUR PRODUCT ONLINE

at championpowerequipment.com



1-877-338-0999

or visit championpowerequipment.com

READ AND SAVE THIS MANUAL. This manual contains important safety precautions which should be read and understood before operating the product. Failure to do so could result in serious injury. This manual should remain with the product.
Specifications, descriptions and illustrations in this manual are as accurate as known at the time of publication, but are subject to change without notice.

TABLE OF CONTENTS

Introduction	3	Tilling Tips and Techniques	21
Safety Definitions	3	Tilling Depths	21
Important Safety Instructions	4	Choosing Correct Wheel and Tine Speeds	22
Training	4	Let the Tiller Do the Work	22
Preparation	4	Avoid Tilling Soggy, Wet Soil	22
Operation	4	Preparing Seedbeds	22
Maintenance and Storage	5	Clearing the Tines	23
Fuel Safety	6	Loading and Unloading the Tiller	23
Safety Symbols	7	Maintenance	24
Operation Symbols	9	Tiller Lubrication	24
Safety Labels	10	Check for Oil Leaks	25
Safety Labels	11	Check Hardware	25
Controls and Features	12	Check Tire Pressure	25
Tiller	12	Transmission Gear Oil Service	25
Engine	12	Tines	26
Assembly	14	Checking and Adjusting Forward Drive Belt Tension	26
Unpacking	14	Belt Tension Adjustment	27
Attach Lower Handle	14	Change Forward/Reverse Belts	28
Install the Wheels	14	Engine Cleaning	29
Install the Tines	14	Air Cleaner Service	29
Install the Tine Shield	15	Engine Oil Service	29
Install the Depth Regulator	15	Air Cleaner Maintenance	31
Attach Upper Handle	15	Spark Plug Service	31
Attach Speed Control	15	Spark Arrester Screen Service	31
Attach Front Bumper	15	Transportation and Storage	31
Introduction	16	Off-Season Storage	32
Wheel Drive Pins	16	Removing from Storage	32
Forward Lever	17	Specifications	33
Reverse Lever	17	Tiller Specifications	33
Depth Regulator Lever Adjustment	17	Engine Specifications	33
Handlebar Height Adjustment	18	Fuel Specifications	33
Operation	18	Parts Diagram	34
Introduction	18	Parts List	38
Add Fuel	18	Engine Parts Diagram	41
Add Engine Oil	19	Engine Parts List	42
Transmission Gear Oil	19	Troubleshooting	44
Starting the Engine	19	Difficulty Starting Engine (Recoil)	45
Stopping the Engine and the Tiller	20	Gasoline Engine: No Power	46
Operation at High Altitude	21	Gasoline Engine Running Roughly	46
		Stops Suddenly When Running	47
		Engine is Overheating	47

INTRODUCTION

Congratulations on your purchase of a Champion Power Equipment (CPE) product. CPE designs, builds, and supports all of our products to strict specifications and guidelines. With proper product knowledge, safe use, and regular maintenance, this product should bring years of satisfying service.

Every effort has been made to ensure the accuracy and completeness of the information in this manual at the time of publication, and we reserve the right to change, alter and/or improve the product and this document at any time without prior notice.

Since CPE highly values how our products are designed, manufactured, operated and are serviced, and also highly value your safety and the safety of others, we would like you to take the time to review this product manual and other product materials thoroughly and be fully aware and knowledgeable of the assembly, operation, dangers and maintenance of the product before use. Fully familiarize yourself, and make sure others who plan on operating the product fully familiarize themselves too, with the proper safety and operation procedures before each use. Please always exercise common sense and always err on the side of caution when operating the product to ensure no accident, property damage, or injury occurs. We want you to continue to use and be satisfied with your CPE product for years to come.

When contacting CPE about parts and/or service, you will need to supply the complete model and serial numbers of your product. Transcribe the information found on your product's nameplate label to the table below

CPE TECHNICAL SUPPORT TEAM
1-877-338-0999
MODEL NUMBER
100380
SERIAL NUMBER
DATE OF PURCHASE
PURCHASE LOCATION

SAFETY DEFINITIONS

The purpose of safety symbols is to attract your attention to possible dangers. The safety symbols, and their explanations, deserve your careful attention and understanding. The safety warnings do not by themselves eliminate any danger. The instructions or warnings they give are not substitutes for proper accident prevention measures.

DANGER

DANGER indicates a hazardous situation which, if not avoided, will result in death or serious injury.

WARNING

WARNING indicates a hazardous situation which, if not avoided, could result in death or serious injury.

CAUTION

CAUTION indicates a hazardous situation which, if not avoided, could result in minor or moderate injury.

NOTICE

NOTICE is used to address practices not related to physical injury.

IMPORTANT SAFETY INSTRUCTIONS

WARNING

Cancer and Reproductive Harm – www.P65Warnings.ca.gov

This machine meets voluntary safety standard B71.8 – 1996, which is sponsored by the Outdoor Power Equipment Institute, Inc., and is published by the American National Standards Institute.

Training

1. Carefully read this Operator's Manual and any other literature you may receive. Be thoroughly familiar with the controls and the proper use of the tiller and its engine. Know how to stop the unit and disengage the controls quickly.
2. Never allow children under age 16 to operate the tiller. Never allow adults to operate the tiller without proper instruction.
3. Keep the area of operation clear of all persons, particularly children and pets.
4. Keep in mind that the operator or user is responsible for accidents or hazards occurring to other people, their property, and themselves.

Preparation

1. Thoroughly inspect the area where the tiller is to be used and remove all foreign objects.
2. Be sure all tiller controls are released and both wheels are in the Wheel Drive position before starting the engine.
3. Do not operate the tiller without wearing adequate outer garments. Avoid loose garments or jewelry that could get caught in moving parts.
4. Do not operate the tiller when barefoot or wearing sandals, sneakers, or light footwear. Wear protective footwear that will improve footing on slippery surfaces.
5. Do not till near underground electric cables, telephone lines, pipes or hoses. If in doubt, contact your telephone or utility company.
6. Warning: Handle fuel with care; it is highly flammable and its vapors are explosive. Take the following precautions:
 - 6a. Store fuel in containers specifically designed for this purpose.
 - 6b. The gas cap shall never be removed or fuel added while the engine is running. Allow the engine to cool for several minutes before adding fuel.
 - 6c. Keep matches, cigarettes, cigars, pipes, open flames and sparks away from the fuel tank and fuel container.

- 6d. Fill fuel tank outdoors with extreme care. Never fill fuel tank indoors. Use a funnel or spout to prevent spillage.
 - 6e. Replace all fuel tank and container caps securely.
 - 6f. If fuel is spilled, do not attempt to start the engine, but move the machine away from the area of spillage and avoid creating any source of ignition until fuel vapors have dissipated.
7. Never make adjustments when engine is running (unless recommended by manufacturer).

Operation

1. Do not put hands or feet near or under rotating parts.
2. DO NOT till in reverse.
3. Exercise extreme caution when on or crossing gravel drives, walks, or roads. Stay alert for hidden hazards or traffic. Do not carry passengers.
4. After striking a foreign object, stop the engine, remove the wire from the spark plug and prevent it from touching the spark plug. Thoroughly inspect the machine for any damage and repair the damage before restarting and operating the machine.
5. Exercise caution to avoid slipping or falling.
6. If the unit should start to vibrate abnormally, stop the engine, disconnect the spark plug wire and prevent it from touching the spark plug, and check immediately for the cause. Vibration is generally a warning of trouble.
7. Stop the engine, disconnect the spark plug wire and prevent it from touching the spark plug, whenever you leave the operating position, before unclogging the tines, or when making any repairs, adjustments or inspections.
8. Take all possible precautions when leaving the machine unattended. Stop the engine. Disconnect the spark plug wire and move it away from the spark plug. Be sure that both wheels are in the Wheel Drive position.
9. Before cleaning, repairing, or inspecting, stop the engine and make certain all moving parts have stopped. Disconnect the spark plug wire and prevent it from touching the spark plug to prevent accidental starting.
10. The flap on the tine hood must be down when operating the tiller.
11. Never use the tiller unless proper guards, plates, or other safety protective devices are in place.
12. Do not run the engine in an enclosed area. Engine exhaust contains carbon monoxide gas, a deadly poison that is odorless, colorless, and tasteless.
13. Keep children and pets away.

14. **Never operate the tiller under engine power if the wheels are in the Freewheel position.** In the Freewheel position, the wheels will not hold the tiller back and the revolving tines could propel the tiller rapidly, possibly causing loss of control. Always engage the wheels with the wheel drive pins in the Wheel Drive position before starting the engine or engaging the tines/wheels with the forward or reverse controls.
15. **Be aware that the tiller may unexpectedly bounce upward or jump forward if the tines should strike extremely hard packed soil, frozen ground, or buried obstacles like large stones, roots, or stumps.** If in doubt about the tilling conditions, always use the following operating precautions to assist you in maintaining control of the tiller:
 - 15a. Use shallower depth regulator settings, working gradually deeper with each pass.
 - 15b. Use slower engine speeds.
 - 15c. Clear the tilling area of all large stones, roots or other debris.
 - 15d. Avoid using downward pressure on the handlebars. If need be, use slight upward pressure to keep the tines from digging too deeply.
 - 15e. In an emergency, stop the tines and wheels by releasing whichever lever is engaged. Do not attempt to restrain the tiller.
16. Do not overload the tiller's capacity by attempting to till too deeply at too fast a rate.
17. Never operate the tiller at high transport speeds on hard or slippery surfaces. Look behind and use care when backing up.
18. Do not operate the tiller on a slope that is too steep for safety (greater than 15 degrees). When on slopes, slow down and make sure you have good footing. Never permit the tiller to freewheel down slopes.
19. Never allow bystanders near the unit.
20. Never operate the tiller without good visibility or light.
21. Never operate the tiller if you are tired; or under the influence of alcohol, drugs or medication.
22. Operators shall not tamper with the engine-governor settings on the machine; the governor controls the maximum safe operating speed to protect the engine and all moving parts from damage caused by overspeed. Authorized service shall be sought if a problem exists.
23. Do not touch engine parts which may be hot from operation. Let parts cool down sufficiently.
24. Please remember: You can always stop the tines and wheels by releasing control levers (whichever control is engaged).
25. Never pull the tiller towards you.
26. Start the engine carefully according to instructions and with feet well away from the tines.
27. Never pick up or carry a machine while the engine is running.

Maintenance and Storage

1. Check all nuts, bolts, and screws for proper tightness to be sure the equipment is in safe working condition.
2. Never store the tiller with fuel in the fuel tank inside a building where ignition sources are present, such as hot water and space heaters, furnaces, clothes dryers, stoves, electric motors, etc. Allow the engine to cool before storing the unit in any enclosure.
3. To reduce the chances of a fire, keep the engine free of grass, leaves, or excessive grease.
4. Store gasoline in a cool, well-ventilated area, safely away from any spark- or flame-producing equipment. Store gasoline in an approved container, safely away from the reach of children.
5. Never perform maintenance while the engine is running or the spark plug wire is connected, except when specifically instructed to do so.
6. If the fuel tank has to be drained, do this outdoors.

Fuel Safety

⚠ DANGER

GASOLINE AND GASOLINE VAPORS ARE HIGHLY FLAMMABLE AND EXPLOSIVE.

Fire or explosion can cause severe burns or death.

Gasoline and gasoline vapors:

- Gasoline is highly flammable and explosive.
- Gasoline can cause a fire or explosion if ignited.
- Gasoline is a liquid fuel but it's vapors can ignite.
- Gasoline is a skin irritant and needs to be cleaned up immediately if spilled on skin or clothes.
- Gasoline has a distinctive odor, this will help detect potential leaks quickly.
- In any petroleum gas fire, flames should not be extinguished unless by doing so the fuel supply valve can be turned OFF. This is because if a fire is extinguished and a supply of fuel is not turned OFF, then an explosion hazard could be created.
- Gasoline expands or contracts with ambient temperatures. Never fill the gasoline tank to full capacity, as gasoline needs room to expand if temperatures rise.

When adding or removing gasoline:

Turn the tiller off and let it cool for at least two minutes before removing the gasoline cap. Loosen the cap slowly to relieve pressure in the tank.

Only fill or drain gasoline outdoors in a well-ventilated area.

DO NOT pump gasoline directly into the tiller at the gas station. Use an approved container to transfer the fuel to the tiller.

DO NOT overfill the gasoline tank.

Always keep gasoline away from sparks, open flames, pilot lights, heat and other sources of ignition.

DO NOT light or smoke cigarettes.

When starting the tiller:

DO NOT attempt to start a damaged tiller.

Make certain that the gasoline cap, air filter, spark plug, fuel lines and exhaust system are properly in place.

Allow spilled gasoline to evaporate fully before attempting to start the engine.

Make certain that the tiller is resting firmly on level ground.

When operating the tiller:

DO NOT tip the tiller or allow fuel or oil to spill.

When transporting or servicing the tiller:

Make certain that the fuel valve is in the OFF position and the gasoline tank is empty.

Disconnect the spark plug wire.

When storing the tiller:

Store away from sparks, open flames, pilot lights, heat and other sources of ignition.







Do not store tiller or gasoline near furnaces, water heaters, or any other appliances that produce heat or have automatic ignitions.





⚠ WARNING

Never use a gasoline container, gasoline tank, or any other fuel item that is damaged or appears damaged.

Safety Symbols

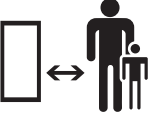







Some of the following symbols may be used on this product. Please study them and learn their meaning. Proper interpretation of these symbols will allow you to more safely operate the product.









SYMBOL	MEANING
	Read Operator's Manual. To reduce the risk of injury, user must read and understand operator's manual before using this product.
	Eye and Ear Protection. Always wear safety goggles or safety glasses with side shields, and as necessary a full face-shield as well as full ear protection when operating this product. Always wear eye protection with side shields marked to comply with ANSI Z87.1.
	Footwear. Always wear safety shoes or heavy boots when operating the machine.
	Gloves. Always wear nonslip, heavy-duty protective gloves when operating this product.
	Safety Alert. This machine was built to be operated according to the safe operation practices in this manual. As with any type of power equipment, carelessness or error on the part of the operator can result in serious injury. This machine is capable of amputating fingers, hands, toes and feet and throwing foreign objects. Failure to observe the safety instructions could result in serious injury or death.
	Fire/Explosion. Fuel and its vapors are extremely flammable and explosive. Fire or explosion can cause severe burns or death. Operation of this equipment may create sparks that can start fires around dry vegetation. A spark arrestor may be required. The operator should contact local fire agencies for laws or regulations relating to fire prevention requirements.
	Hot Surface. To reduce the risk of injury or damage, avoid contact with any hot surface.
	Open Flame Alert. Fuel and its vapors are extremely flammable and explosive. Keep fuel away from smoking, open flames, sparks, pilot lights, heat, and other ignition sources.

SYMBOL	MEANING
	<p>Toxic Fumes. The engine exhaust from this product contains chemicals known to cause cancer, birth defects and other reproductive harm.</p> <p>Risk of Asphyxiation. This engine emits carbon monoxide, an odorless, colorless poison gas. Breathing carbon monoxide can cause nausea, fainting or death. Use only in a well-ventilated area.</p>
	<p>Clearance. Keep all objects including others at least 10 feet (3m) from this machine. Only one person should operate the tiller and load the logs.</p>
	<p>Rotating Tines. Avoid injury from rotating tines. Keep hands away.</p>
	<p>Rotating Tines. Avoid injury from rotating tines. Keep feet away.</p>
	<p>Thrown Objects. This machine may pick up and throw objects which can cause serious personal injury.</p>

Operation Symbols

Some of the following symbols may be used on this product. Please study them and learn their meaning. Proper interpretation of these symbols will allow you to more safely operate the product.

SYMBOL	MEANING
	Check Oil Level. Recommended oil is 10W-30. The engine can be seriously damaged without oil. Always check the oil level before using. The machine must be resting firmly on level ground when checking.
	Check Fuel Level. Use clean, fresh, regular unleaded gasoline with a minimum octane rating of 85 and an ethanol content of less than 10% by volume.
	Engine Switch ON. Turn the Engine Switch to "ON" position.
	Choke. Move choke lever to "CHOKE" position.
	Throttle: Full Speed. Move the throttle lever to full speed to start the engine.
	Fuel Valve ON. Move the fuel valve lever to "ON" position.
	Recoil Starter. Pull recoil starter to start the engine.
	Choke RUN. Move choke lever to "RUN" position.

SYMBOL	MEANING
	Throttle: Low Speed.
	Fuel Valve OFF.
	Forward.
	Reverse.
	Engage Wheels and Tines.
	Disengage Wheels and Tines.
	Speed.
	Transmission Gear Oil. API rated GL-4 or GL-5 Viscosity of SAE 140, SAE 85W-140 or SAE 80W-90.

Safety Labels

These labels warn you of potential hazards that can cause serious injury. Read them carefully.

If a label comes off or becomes hard to read, contact Technical Support Team for possible replacement.

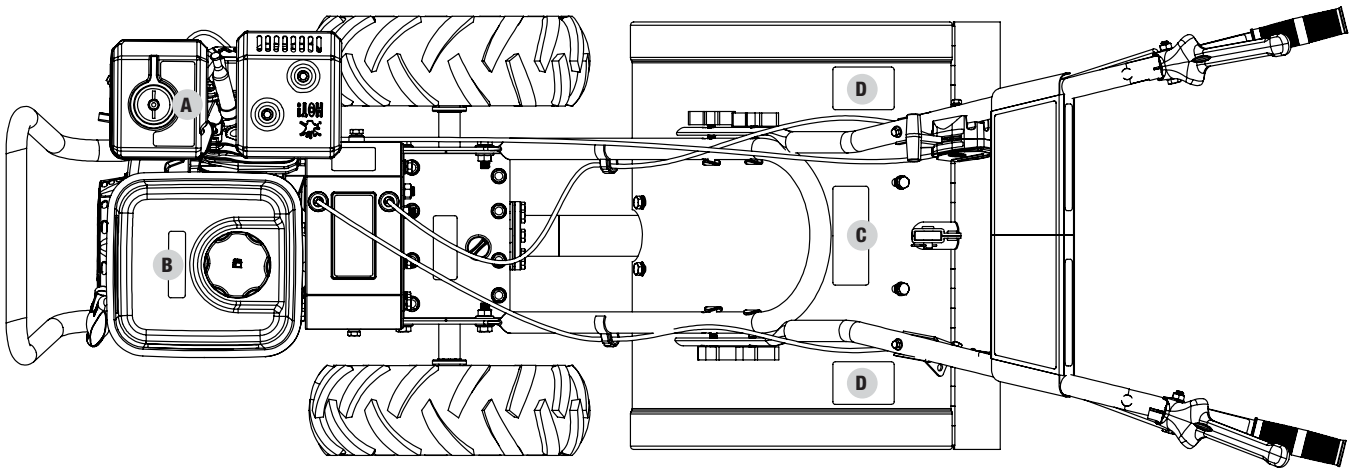

	LABEL	DESCRIPTION
A		Hot Surface
B		Fuel
C		Safety Icons
D		Safety Icons

Safety Labels

These labels warn you of potential hazards that can cause serious injury. Read them carefully.

If a label comes off or becomes hard to read, contact Technical Support Team for possible replacement.

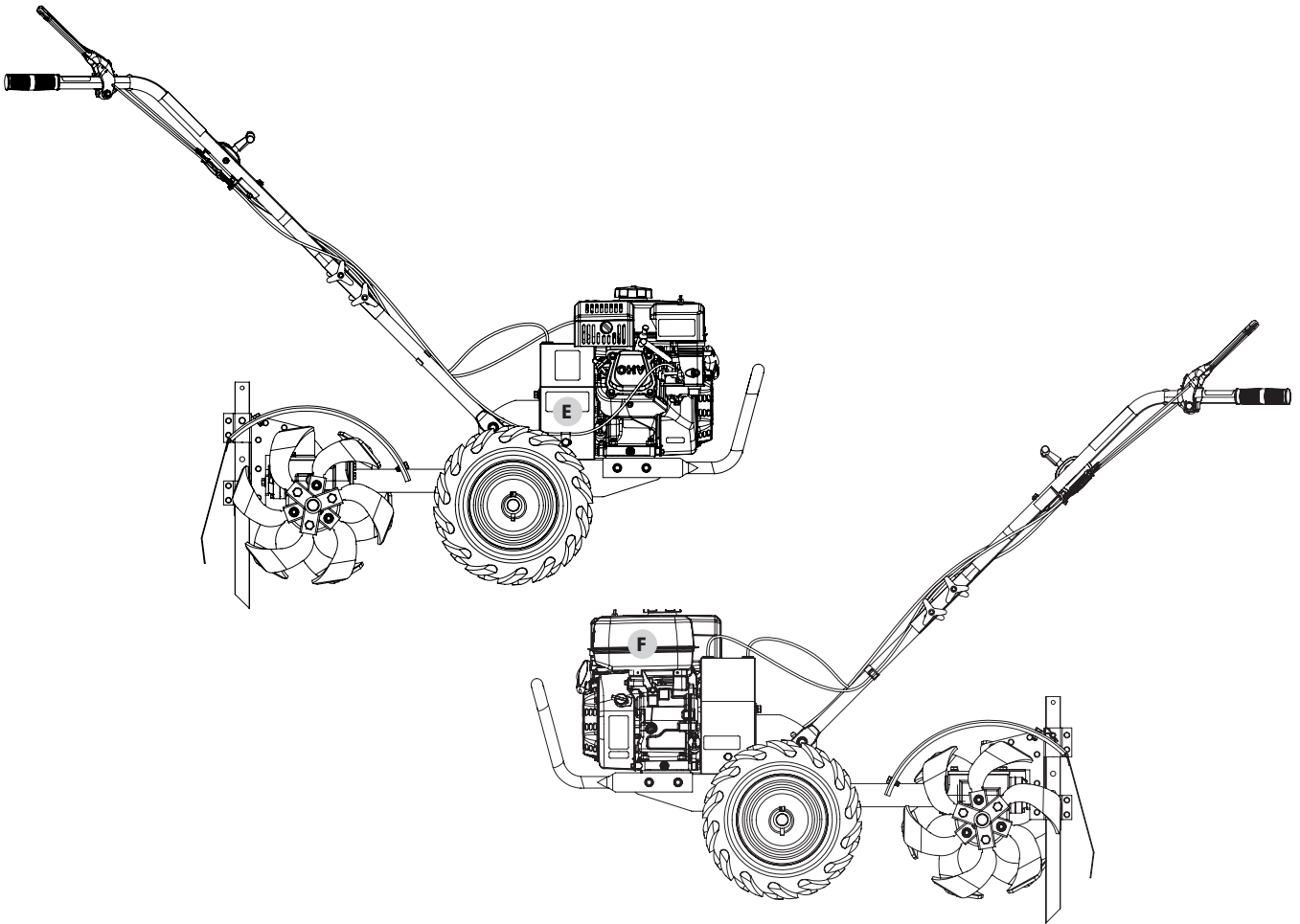

	LABEL	DESCRIPTION
E		Combustion
F		Safety Icons

CONTROLS AND FEATURES

Read this operator's manual before operating your tiller. Familiarize yourself with the location and function of the controls and features. Save this manual for future reference.

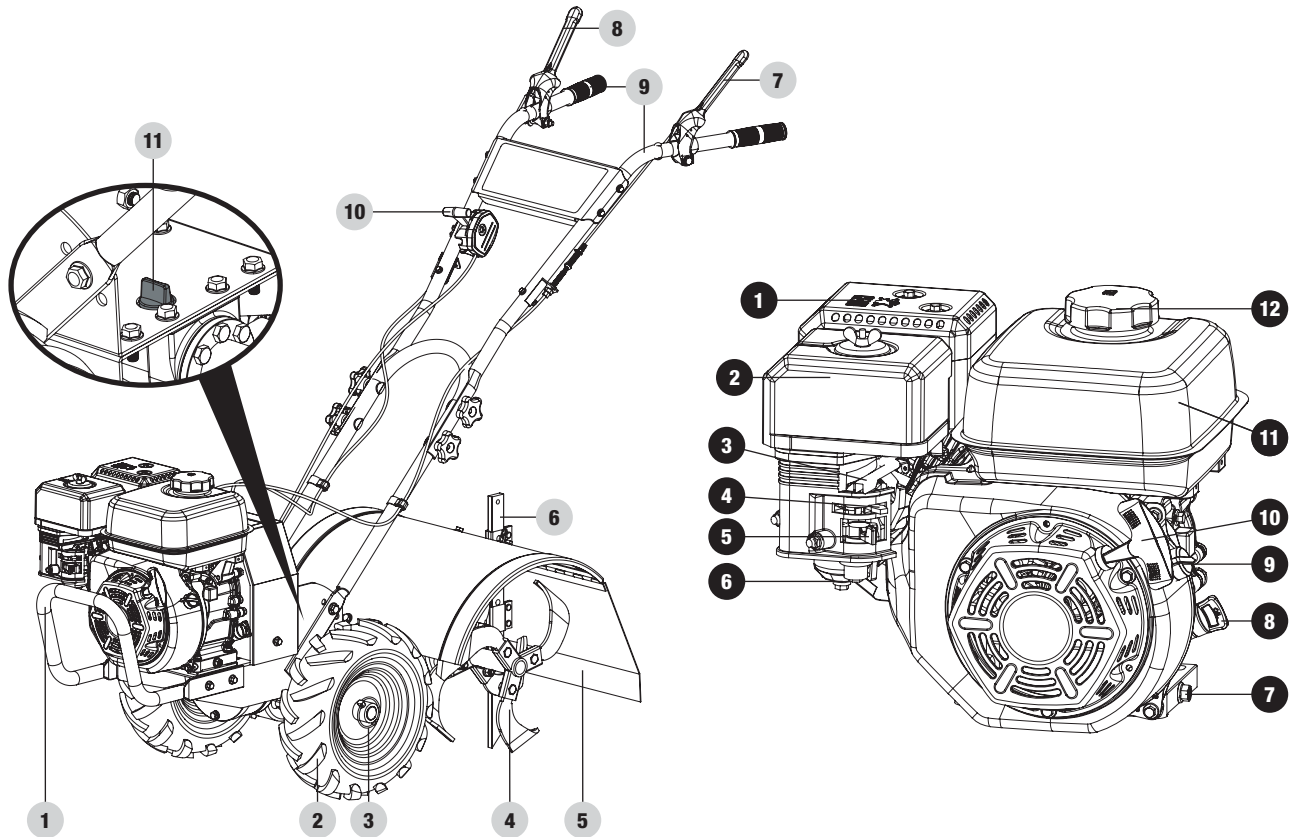

Tiller

1. Front Bumper
2. Wheels
3. Wheel Lock Pins
4. Tines
5. Tine Shield
6. Depth Regulator Lever
7. Reverse Lever
8. Forward Lever
9. Handlebars
10. Speed Control
11. Gear Oil Dipstick

Engine

1. **Muffler**
2. **Air Filter** – Protects the engine by filtering dust and debris from the intake air.
3. **Throttle**
4. **Choke** – Used to start the engine.
5. **Fuel Valve** – Used to turn fuel supply on and off to engine.
6. **Carburetor**
7. **Oil Drain Bolt** – Used to drain the oil.
8. **Oil Fill Cap/Dipstick** – Used to check and fill oil level.
9. **Engine On/Off Switch**
10. **Recoil Starter** – Used to manually start the engine.
11. **Gasoline Tank** – 0.9 gal. (3.2 L)
12. **Gasoline Tank Cap**

Parts Included

Accessories

- Engine Oil (0.6 qt.) 1
- Oil Funnel 1

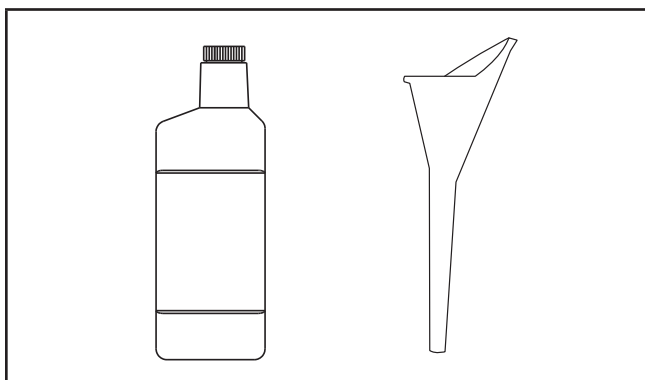

Tools Included

- 8-10 Wrench 1
- 12-14 Wrench 1
- 13-16 Wrench 1
- Spark Plug Wrench (engine) 1

Tools Not Included

- Needle Nose Pliers (for cotter pins) 1

ASSEMBLY

Your tiller requires some assembly. This unit ships from our factory without oil. It must be properly serviced with fuel and oil before operation.

If you have any questions regarding the assembly of your tiller, call our Technical Support Team at 1-877-338-0999. Please have your serial number and model number available.

Unpacking

1. Remove all parts and packaging components.
2. Remove top lid and remove sides.
3. Remove any remaining packaging.
4. With helper, remove the tiller from the shipping crate.

Attach Lower Handle

1. Loosen the lower handle bolts.
2. Align the lower handle holes to the middle height adjustment holes in the transmission cover and install the (4) M10×25 mm flange head bolts and (4) M10 nuts. Tighten all hardware.

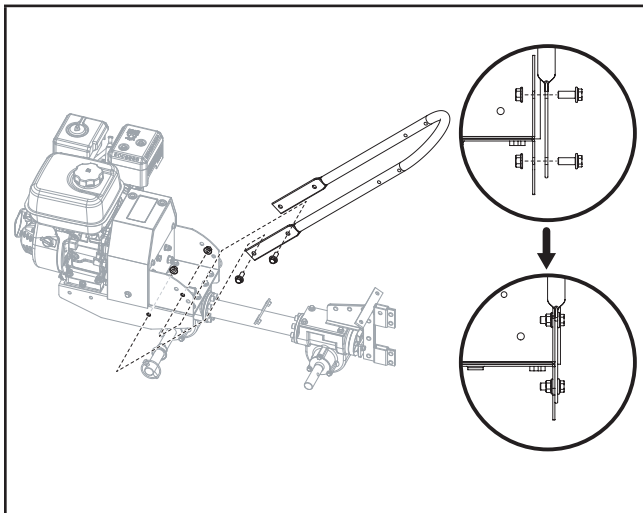

Install the Wheels

1. Remove the locking pins from the wheel hubs.
2. The tiller wheels are directional. For best performance install the wheels with the tire thread facing the direction as shown.
3. Slide the wheel hub onto the wheel axle.
4. Align the wheel hub hole with the hole in the axle and insert the locking pin.
5. Rotate the locking pin ring to lock the pin in position. Repeat on other wheel.

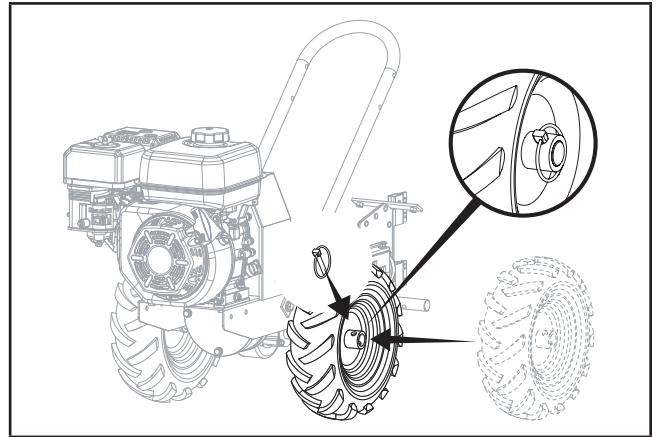

Install the Tines

Before Assembly

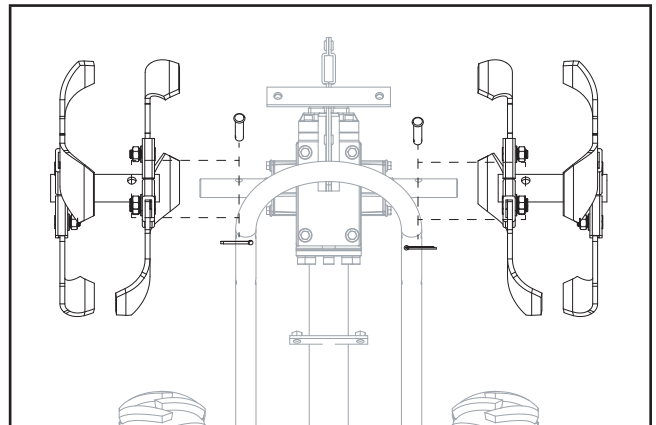

1. Check the orientation of the tine blade. The sharp cutting edge should be facing the direction of tine rotation for your tiller.
2. Install the tine assemblies on each tine axle. Secure with (2) pins and (2) cotter pins. Bend cotter pins once inserted to prevent them from coming out.

After Assembly

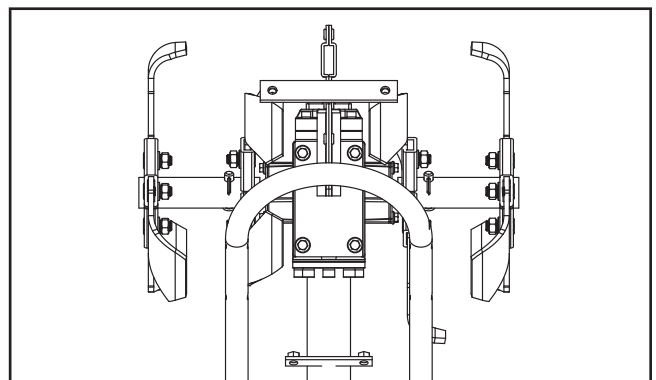

Install the Tine Shield

1. Remove the (4) M10×25 mm flange head bolts installed in the tine shield brackets above the transmission housing.
2. Place the tine shield on the bracket and secure with the bolts removed in step 1.

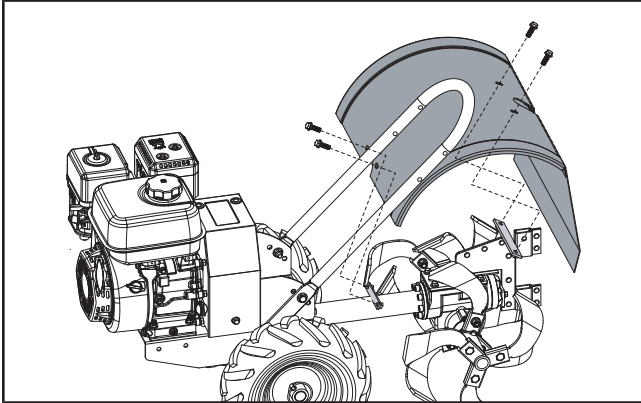

Install the Depth Regulator

1. Remove the (1) pin and (1) clip from the depth regulator lever.
2. Insert the depth regulator into the bottom of the depth regulator bracket.
3. Insert the pin through the bracket and lever.
4. Install the clip removed in 1 onto the depth regulator lever.

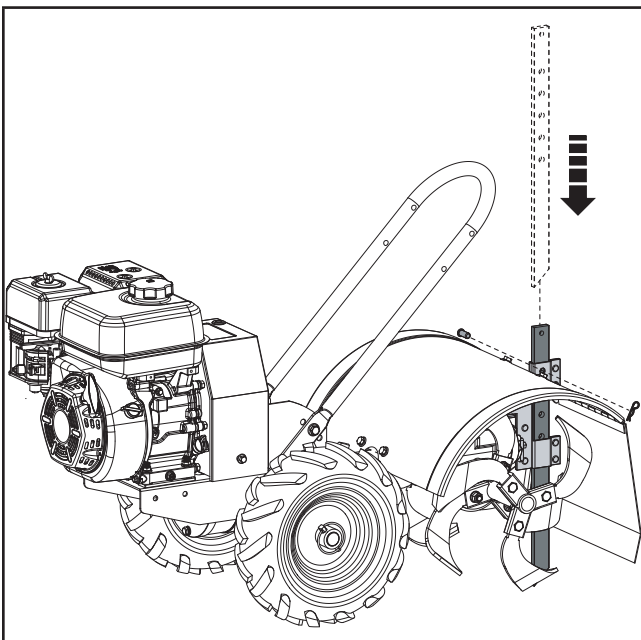

Attach Upper Handle

1. Slide the upper handle down over the lower handle and align the holes.

2. Insert the (4) M8×50 curved head bolts into the holes as shown and secure with the (4) handle knobs and (4) flat washers.
3. Tighten the handle knobs securely.

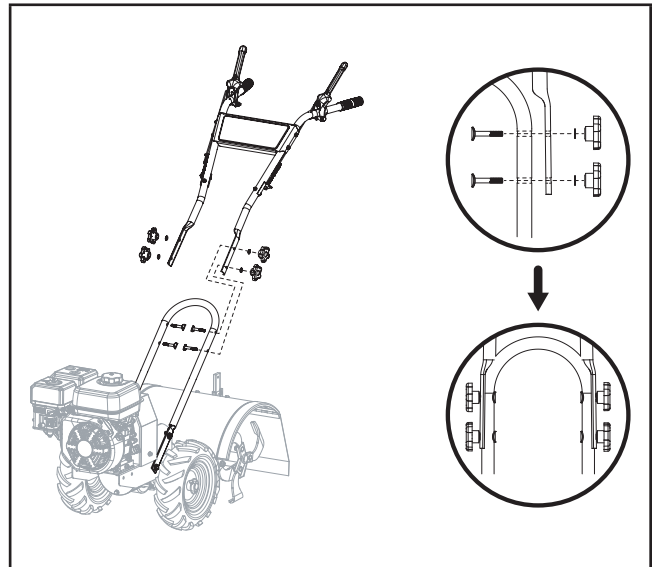

Attach Speed Control

1. Attach speed control using provided (1) M6 bolt, (1) washer, and (1) M6 nut.
2. Tighten completely.
3. Use plastic clips to secure the cables as shown.

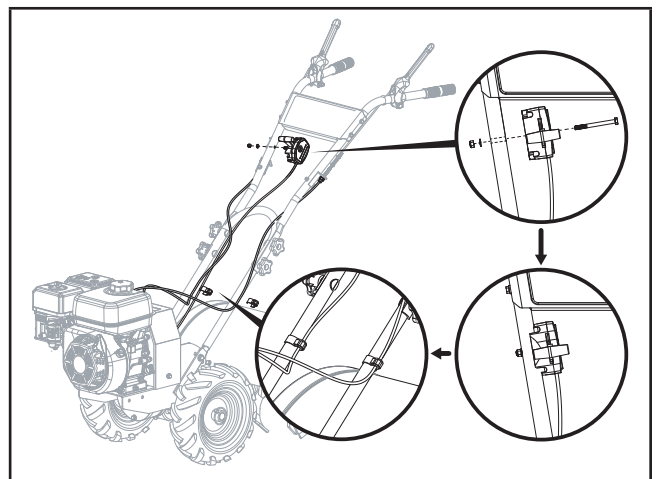

Attach Front Bumper

1. Slide the front bumper onto the outside of the base frame and align the holes.
2. Install the (4) M8×25 mm bolts and (4) M8 lock nuts and tighten securely.

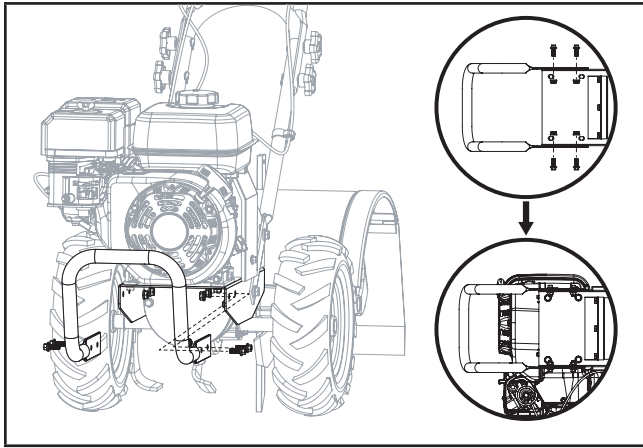

⚠ WARNING

Before operating your machine, carefully read and understand all safety, controls and operating instructions.

Failure to follow these instructions can result in serious personal injury.

Introduction

This section describes the location and function of the controls on your tiller. Refer to the following Section, Operation, for detailed operating instructions.

Practice using these controls, with the engine shut off, until you understand the operation of the controls and feel confident with each of them.

Wheel Drive Pins

Each wheel is equipped with a locking pin that secures the wheel to the wheel shaft. The wheels can be positioned in either a WHEEL DRIVE or a FREEWHEEL mode.

Before starting the engine, put both wheels in the WHEEL DRIVE position by inserting the wheel drive pins through the wheel hubs and axle shaft. Doing so “locks” the wheels to the axle shaft, causing the wheels to turn when either the forward or reverse lever is engaged.

Use the FREEWHEEL mode only when the engine is not running. In FREEWHEEL, the wheel locking pins are placed only through the holes in the wheel shaft (not the wheel hubs), thus allowing the wheels to turn freely when you manually move the tiller

⚠ WARNING

Never allow either of the wheels to be in the FREEWHEEL position when the engine is running. Always put both wheels in the WHEEL DRIVE position before starting the engine.

Failure to comply could cause loss of tiller control, property damage, or personal injury.

To replace the wheels in the WHEEL DRIVE or FREEWHEEL:

1. Stop the engine, disconnect the spark plug wire from the spark plug and allow engine to cool.
2. Raise one wheel about 1 in. (2.5 cm) off the ground and place a sturdy support under the transmission.

⚠ WARNING

Do not place tiller on its side when changing wheel drive positions. Doing so could result in gasoline leaking from the fuel tank.

Failure to follow this instruction could result in personal injury or property damage.

FOR WHEEL DRIVE MODE: Slide wheel outward and align the holes. Insert locking pin through wheel hub and wheel shaft. Secure wheel locking pin by pushing in as far as it will go then wrapping ring around the wheel shaft as shown. Repeat with the other wheel and then remove the support from beneath the transmission.

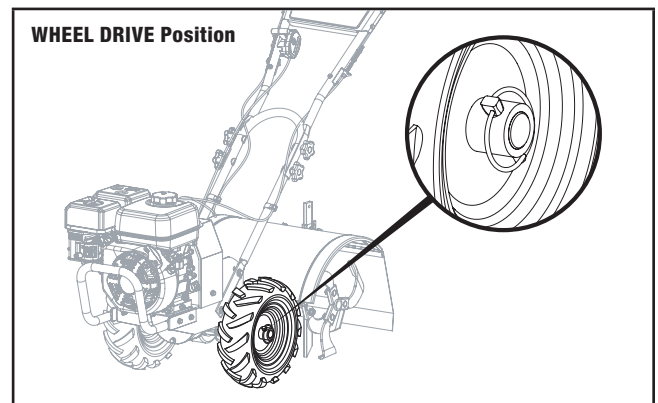

FOR FREEWHEEL MODE: Slide the wheel inward and insert the wheel drive locking pin only through the hole in the axle shaft. Secure wheel locking pin by pushing in as far as it will go then wrapping ring around the wheel shaft as shown. Repeat for the other wheel and then remove the support from beneath the transmission.

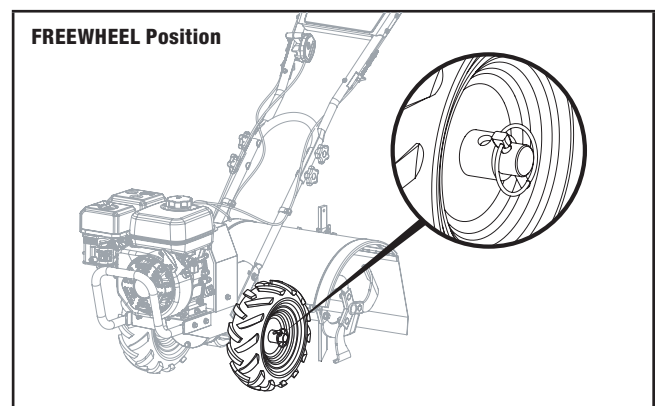

⚠ WARNING

Before starting engine, be sure that both wheels are in WHEEL DRIVE position. See Wheel Drive Pins for instructions.

Engaging the Forward Lever when the wheels are not in WHEEL DRIVE could allow the tines to rapidly propel the tiller forward or backward. Failure to comply could cause loss of tiller control, property damage, or personal injury

Forward Lever

The Forward Lever controls the engagement of forward drive to the wheels and counter-rotating tilling with the tines.

To operate the Forward Lever:

1. Put wheels in WHEEL DRIVE position (see “WARNING” statement).
2. Depress and hold the lever against the handlebar to start the wheels going forward and tines rotating in a reverse direction.
3. Release the lever to disengage (stop) the wheels and tines (the engine will continue to run).

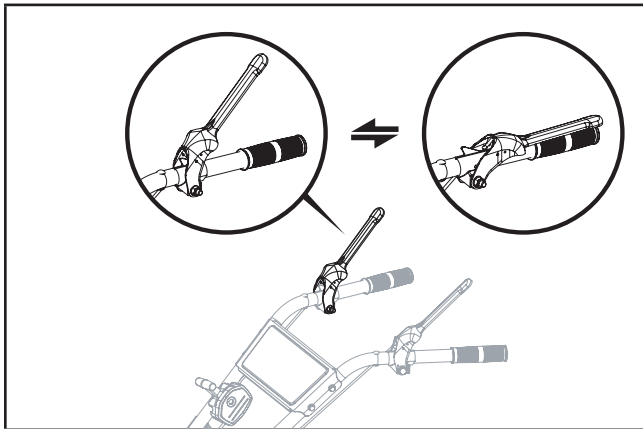
**⚠ WARNING**

Never pull the tiller toward you with the tines engaged.

Reverse Lever

The reverse lever controls the reverse motion of the wheels and forward motion of the tines. To operate the Reverse Lever:

1. Put wheels in WHEEL DRIVE position (see “WARNING” statement).
2. Ensure all tiller tine motion has stopped before re-engaging tines.

3. Depress and hold the lever against the handlebar to start the wheels in reverse and tines rotating in a forward direction.
4. Release the lever to disengage (stop) the wheels and tines (the engine will continue to run).

⚠ WARNING

DO NOT till in reverse.

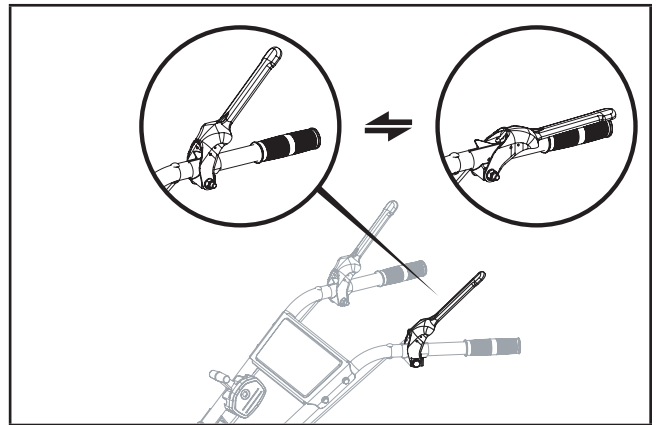
**Depth Regulator Lever Adjustment**

This regulator lever controls the tilling depth of the tines. Remove pin and clip and slide regulator lever up or down as required. Reassemble pin and clip.

The “travel position” (highest hole) raises the tines approximately 1-1/2 in. (4 cm) off the ground, allowing the tiller to be moved without the tines contacting the ground. This setting should also be used when starting the engine.

Moving the regulator lever upward will increase the tilling depth. The lowest notch allows a tilling depth of approximately 6 in. (15 cm), depending on soil conditions. For best results, always begin tilling at a very shallow depth setting and gradually increase the tilling depth.

⚠ WARNING

Do not attempt to till too deeply too quickly.

Gradually work down to deeper tilling depths.

Place the Depth Regulator Lever in the “travel” position before starting the engine. This position prevents the tines from touching the ground until you are ready to begin tilling.

Failure to follow this warning could result in personal injury or property damage.

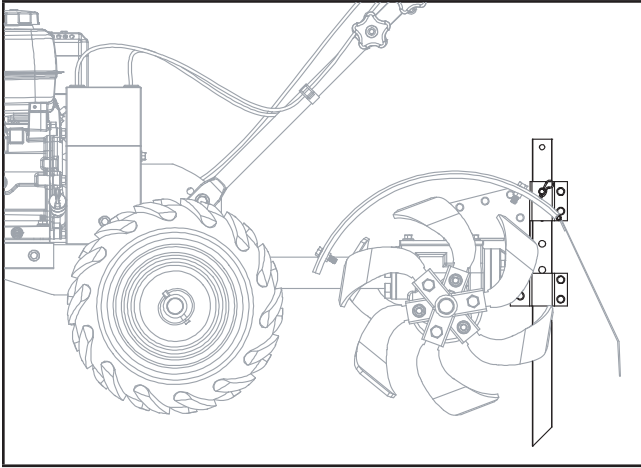

Handlebar Height Adjustment

The handlebar height is adjustable to three different settings. In general, adjust the handlebars so they are at waist level when the tines are 3-4 in. in the soil.

To adjust the handlebars:

1. Stop engine, disconnect spark plug wire from spark plug, and allow engine to cool.
2. Remove hardware, reposition handlebars, and reinstall hardware securely.

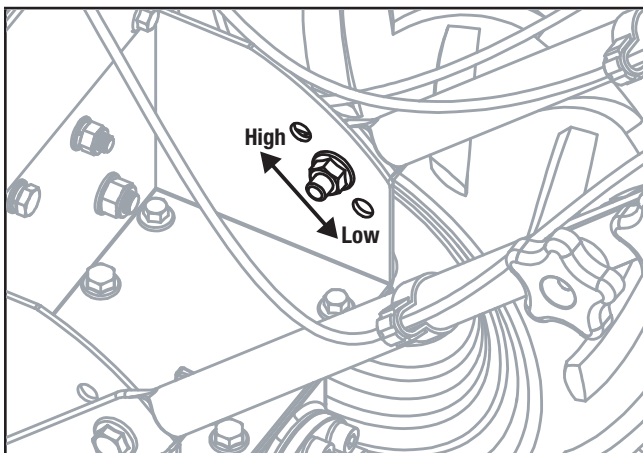

OPERATION

⚠ WARNING

Before operating your machine, carefully read and understand all safety, controls and operating instructions in this Operator's Manual.

Failure to follow these instructions can result in serious personal injury

Introduction

Read this section before you start the engine. Then, take the time to familiarize yourself with the basic operation of the tiller before using it in the garden. Find an open, level area and practice using the tiller controls without the tines engaging the soil (put tines in "travel" setting). Only after you've become completely familiar with the tiller should you begin using it in the garden.

Add Fuel

1. Use clean, fresh, regular unleaded gasoline with a minimum octane rating of 85 and an ethanol content of 10% or less by volume. **E10 E25 E85**
2. DO NOT mix oil with gasoline.
3. Remove the gasoline cap.
4. Slowly add gasoline to the tank. DO NOT OVERFILL.

Gasoline can expand after filling. A minimum of ¼ in. (6.4 mm) of space left in the tank is required for gasoline expansion although more than ¼ in. (6.4 mm) is recommended. Gasoline can be forced out of the tank as a result of expansion if overfilled and can affect the stable running condition of the tiller.

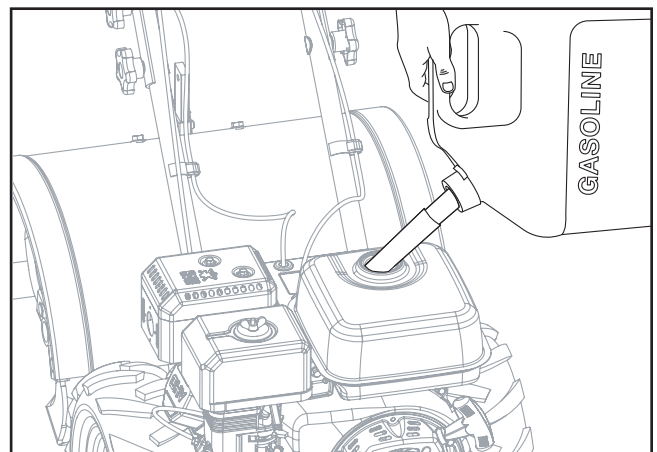

⚠ CAUTION

Use regular unleaded gasoline with a minimum octane rating of 85 and an ethanol content of 10% or less by volume.

DO NOT mix oil and gasoline.

Fill tank to approximately ¼ in. (6.4 mm) below the top of the tank to allow for gasoline expansion.

DO NOT pump gasoline directly into the tiller at the pump. Use an approved container to transfer the gasoline to the tiller.

DO NOT fill tank indoors.

DO NOT fill tank when the engine is running or hot.

DO NOT overfill the tank.

DO NOT light cigarettes or smoke when filling the tank.

⚠ WARNING

Pouring gasoline too fast through the fuel screen may result in blow back of gasoline at the operator while filling.

🗨 NOTICE

Our engines work well with 10% or less ethanol blend gasoline. When using ethanol-gasoline blends there are some issues worth noting:

- Ethanol-gasoline blends can absorb more water than gasoline alone.
- These blends can eventually separate, leaving water or a watery goo in the tank, fuel valve and carburetor.
- With gravity-fed supplies, the compromised gasoline can be drawn into the carburetor and cause damage to the engine and/or potential hazards.
- There are only a few suppliers of fuel stabilizer that are formulated to work with ethanol-gasoline blends.
- Any damages or hazards caused by using improper gasoline, improperly stored gasoline, and/or improperly formulated stabilizers, are not covered by manufacturer's warranty.

It is advisable to always shut off the gasoline supply, run the engine to starvation and drain the tank when the equipment is not in use for more than 30 days.

Add Engine Oil

1. Place tiller on a flat, level surface.
2. Put the wheels in the WHEEL DRIVE position.

3. Remove oil fill cap/dipstick to add engine oil.
4. Using a funnel, add up to 0.6 qt. (0.6 L) of oil and replace oil fill cap/dipstick. DO NOT OVERFILL.
5. Check engine oil level and add as needed.

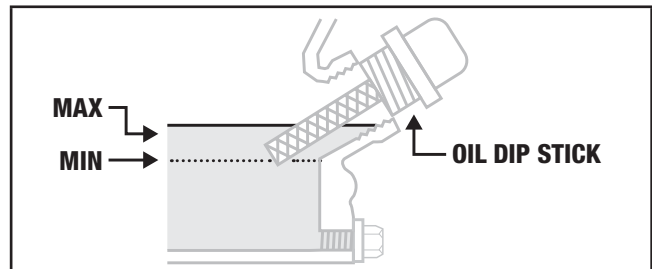

Recommended Oil Type									
		10W-30							
	5W-30			10W-40					
	5W-30 Synthetic								
°F	-20	0	20	40	60	80	100	120	
°C	-28.9	-17.8	-6.7	4.4	15.6	26.7	37.8	48.9	
	Ambient temperature								

Transmission Gear Oil

The tiller ships from the factory with transmission gear oil installed. Operating the tiller when the transmission is low on oil can result in severe damage. See checking or adding Transmission Gear Oil Service for more details.

Starting the Engine

To help prevent serious personal injury or damage to equipment

⚠ WARNING

Do not attempt to engage the tines or wheels until you have read all of the operating instructions

⚠ WARNING

Before starting engine, put both wheels in the WHEEL DRIVE position. Never have wheels in FREEWHEEL position when engine is running. When the wheels are in FREEWHEEL, they do not hold back the tiller and the tines could propel the tiller rapidly forward or backward.

⚠ WARNING

Never run engine indoors or in enclosed, poorly ventilated areas. Engine exhaust contains carbon monoxide, an odorless and deadly gas.

⚠ WARNING

Keep away from rotating tines. Rotating tines will cause injury.

1. Make certain the tiller is on a flat, level surface. Tilling on a grade greater than 15 degrees can be unsafe and cause a low oil shut-off as oil pools in the engine opposite the low oil sensor.
2. Put the wheels in the WHEEL DRIVE position (wheel pins must be through holes in wheel hubs and wheel shaft).
3. Move the Depth Regulator Lever all the way down to the "travel" position, so that the tines clear the ground.
4. Release all controls on the tiller.
5. Flip engine switch to the "ON" position.

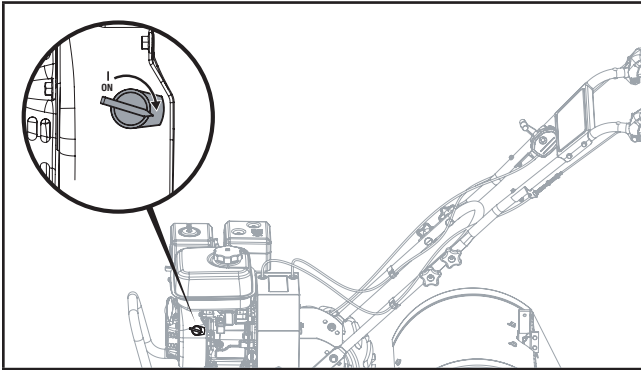

6. Move the choke lever to the "Choke" position.
7. Move the throttle lever to the "Fast" position.
8. Move the fuel valve to the "ON" position.

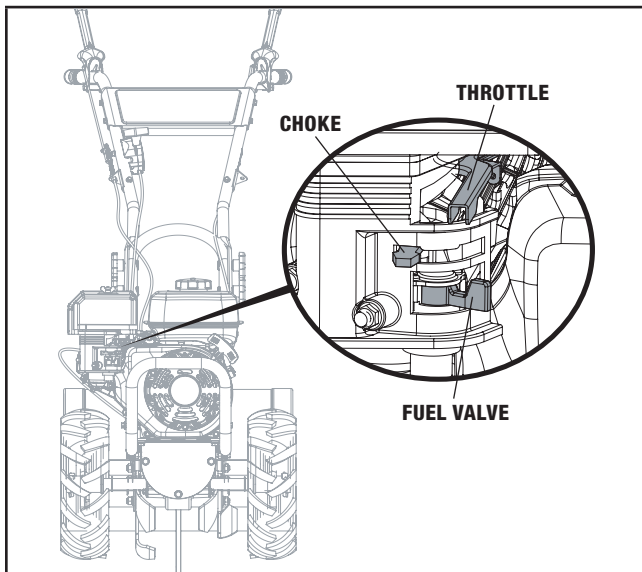

9. Pull the starter cord slowly until resistance is felt and then pull rapidly.

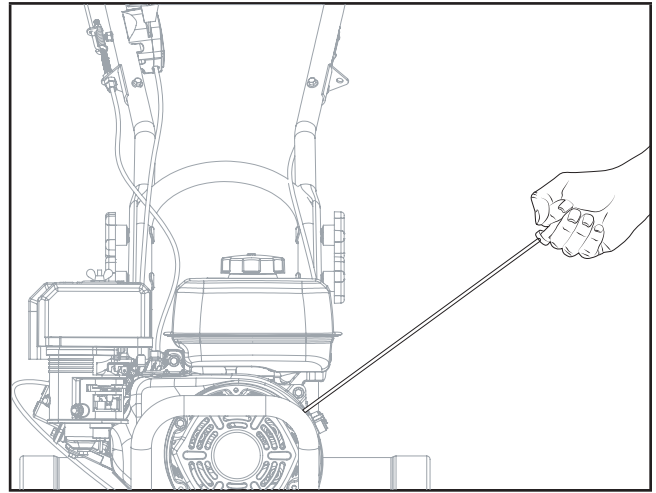

10. As engine warms up, move the choke lever to the "Run" position.

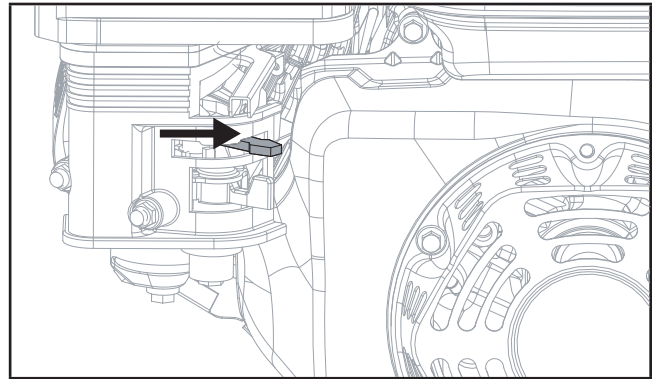
**🗨 NOTICE**

If the engine starts but does not run, make certain that the tiller is on a flat, level surface. The engine is equipped with a low oil sensor that will prevent the engine from running when the oil level falls below a critical threshold.

Stopping the Engine and the Tiller

In an emergency, turn the engine switch to the "OFF" position.

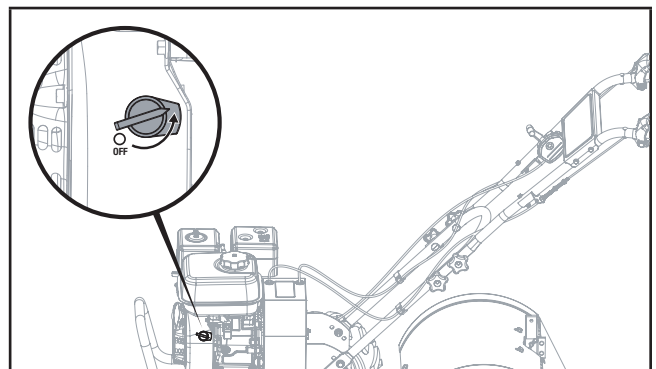

Under normal operation:

1. To stop the wheels and tines, release all control levers.

2. Turn the fuel valve to the "OFF" position.

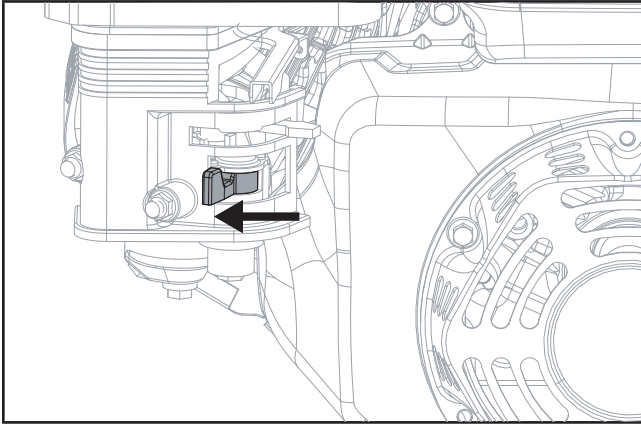

3. Let the engine run until fuel starvation has stopped the engine. This usually takes a few minutes.
4. Turn the engine switch to the "OFF" position.

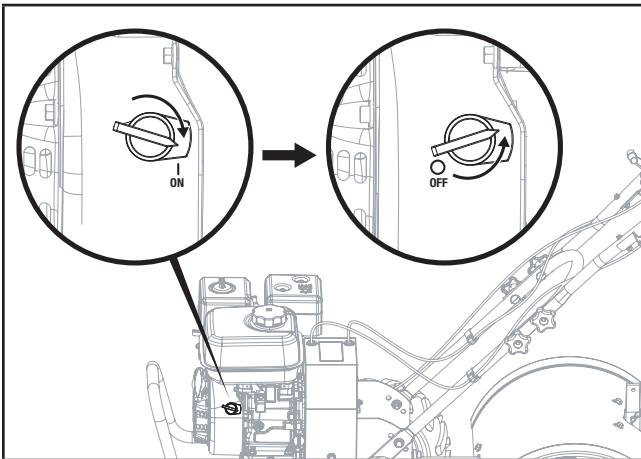

Operation at High Altitude

The density of air at high altitude is lower than at sea level. Engine power is reduced as the air mass and air-fuel ratio decrease. Engine power and generator output will be reduced approximately 3½% for every 1000 ft. of elevation above sea level. This is a natural trend and cannot be changed by adjusting the engine. At high altitudes increased exhaust emissions can also result due to the increased enrichment of the air fuel ratio. Other high altitude issues can include hard starting, increased fuel consumption and spark plug fouling.

To alleviate high altitude issues other than the natural power loss, CPE can provide a high altitude carburetor main jet. The alternative main jet and installation instructions can be obtained by contacting our Technical Support Team. Installation instructions are also available in the Technical Bulletin area of the CPE website.

The part number and recommended minimum altitude for the application of the high altitude carburetor main jet is listed in the table below.

In order to select the correct high altitude main jet it is necessary to identify the carburetor model. For this purpose, a code is stamped on the side of the carburetor. Select the correct high altitude jet part number corresponding to the carburetor code found on your particular carburetor.

Carb. Code	High Alt. Jet Part Number	Min. Altitude
Z530610	16161-Z010310-0000	3000 ft. (914 m)
	16161-Z050210-0000	6000 ft. (1829 m)

⚠ WARNING

Operation using the alternative main jet at elevations lower than the recommended minimum altitude can damage the engine. For operation at lower elevations, the originally supplied standard main jet must be used. Operating the engine with the wrong engine configuration at a given altitude may increase its emissions and decrease fuel efficiency and performance.

TILLING TIPS AND TECHNIQUES

Tilling Depths

⚠ WARNING

Before tilling, contact your telephone or utilities company and inquire if underground equipment or lines are used on your property. Do not till near buried electric cables, telephone lines, pipes or hoses.

Avoid pushing down on the handlebars in an attempt to force the tiller to dig deeper. Doing so takes the weight off the powered wheels, causing them to lose traction. Without the wheels helping to hold the tiller back, the tines will attempt to propel the tiller – often causing the tiller to skip rapidly across the ground. (Sometimes, slight downward pressure on the handlebars will help get through a particularly tough section of sod or unbroken ground, but in most cases this won't be necessary.)

Avoid trying to dig too deeply too quickly, especially when busting sod or when tilling soil that hasn't been tilled for some time. Use shallow depth regulator settings (only an inch or two deep) for the first passes through the soil. With each succeeding pass, dig another inch or two deeper. (Watering the area a few days prior to tilling will make the tilling easier, as will letting the newly worked soil set for a day or two before making a final, deep tilling pass.)

When cultivating (breaking up surface soil around plants to destroy weeds), adjust the tines to dig only 1 in. to 2 in. (2.5 to 5 cm) deep. Using shallow tilling depths helps prevent injury to plants whose roots often grow close to the surface. If needed, lift up on the handlebars slightly to prevent the tines from digging too deeply. (Cultivating on a regular basis not only eliminates weeds, it also loosens and aerates the soil for better moisture absorption and faster plant growth.)

Choosing Correct Wheel and Tine Speeds

With experience, you will find the “just right” tilling depth and tilling speed combination that is best for your garden.

Set the engine throttle lever at a speed to give the engine adequate power and yet allow it to operate at the slowest possible speed ... at least until you have achieved the maximum tilling depth you desire. Faster engine speeds may be desirable when making final passes through the seedbed or when cultivating. Selection of the correct engine speed, in relation to the tilling depth, will ensure a sufficient power level to do the job without causing the engine to labor.

Let the Tiller Do the Work

While tilling, relax and let the wheels pull the tiller along while the tines do the digging. Walk on the side that is not yet finished (to avoid making footprints in the freshly tilled soil) and lightly, but securely grip the handlebar with just one hand.

Avoid Tilling Soggy, Wet Soil

Tilling wet soil often results in large, hard clumps of soil that can interfere with planting. If time permits, wait a day or two after heavy rains to allow the soil to dry before tilling. Test soil by squeezing it into a ball. If it compresses too easily, it is too wet to till.

Preparing Seedbeds

When preparing a seedbed, go over the same path twice in the first row, then overlap one-half the tiller width on the rest of the passes. When finished in one direction, make a second pass at a right angle. Overlap each pass for best results (in very hard ground, it may take three or four passes to thoroughly pulverize the soil.)

If the garden size will not permit lengthwise and then crosswise tilling, then overlap the first passes by one-half a tiller width, followed by successive passes at one quarter width.

Cultivating

With planning, you can allow enough room between rows to cultivate. Leave room for the hood width, plus enough extra room for future plant growth.

Tilling on Slopes

Read the following recommendations before tilling on slopes:

If you must garden on a moderate slope, please follow two very important guidelines:

1. Till only on moderate slopes, never on steep ground where footing is difficult. Tilling on a grade greater than 15 degrees can be unsafe and cause a low oil shut-off as oil pools in the engine opposite the low oil sensor.
2. We recommend tilling up and down slopes rather than terracing. Tilling vertically on a slope allows maximum planting area and also leaves room for cultivating.

IMPORTANT: When tilling on slopes, be sure the correct oil level is maintained in the engine (check every one-half hour of operation). The incline of the slope will cause the oil to slant away from its normal level and this can starve engine parts of required lubrication. Keep the engine oil level at the full point at all times!

⚠ WARNING

Do not operate tiller on a slope too steep for safe operation. Till slowly and be sure you have good footing. Never permit tiller to freewheel down slopes. Failure to follow this warning could result in personal injury.

Tilling on slopes greater than 15 degrees can be unsafe and cause a low oil shut-off due to oil pooling in the opposite side of the engine to the low oil sensor.

Tilling Up and Down Slopes (Vertical Tilling)

To keep soil erosion to a minimum, be sure to add enough organic matter to the soil so that it has good moisture-holding texture and try to avoid leaving footprints or wheel marks.

When tilling vertically, try to make the first pass uphill as the tiller digs more deeply going uphill than it does downhill. In soft soil or weeds, you may have to lift the handlebars slightly while going uphill. When going downhill, overlap the first pass by about one-half the width of the tiller.

Tilling Across Slopes Without Using Terraces (Horizontal Tilling)

If vertical or terracing gardening aren't practical for you, then you can till laterally across a slope. We don't recommend this method as it can create unsure footing and invites soil erosion.

As in terrace gardening, start at the top of the slope and overlap the first pass by half the width of the tiller. For added stability of the tiller, always keep the uphill wheel in the soft, newly tilled soil.

Terrace Gardening

- When a slope is too steep or too short for vertical tilling, it may be necessary to till across the slope and create

terraced rows. Terraces are rows that are cut into the side of a slope, creating a narrow, but flat area on which to plant.

- On a long slope, you can make several terraces, one below the other.
- Terraces should be only 2-to-3 ft. (60-90 cm) wide. Digging too far into the side of the slope will expose poor subsoil that is unproductive for plants.
- To create a terrace, start at the top of the slope and work down. Go back and forth across the first row.
- Each succeeding lower terrace is started by walking below the terrace you're preparing. For added stability of the tiller, always keep the uphill wheel in the soft, newly tilled soil. Do not till the last 12 in. (30 cm) or more of the downhill outside edge of each terrace. This untilled strip helps prevent the terraces from breaking apart and washing downhill. It also provides a walking path between rows.

Clearing the Tines

The tines have a self-clearing action which eliminates most tangling of debris in the tines. However, occasionally dry grass, stringy stalks or tough vines may become tangled. Follow these procedures to help avoid tangling and to clean the tines, if necessary.

- To reduce tangling, set the depth regulator deep enough to get maximum "chopping" action as the tines chop the material against the ground. Also, try to till under crop residues or cover crops while they are green, moist and tender.
- While power composting, try swaying the handlebars from side to side about 6 in. to 12 in. (15 to 30 cm). This "fishtailing" action often clears the tines of debris.
- If tangling occurs, lift the tines out of the soil and run the tiller in reverse (if unit is equipped with powered reverse) for a few feet. This reversing action should unwind a good deal of debris.
- It may be necessary to remove the debris by hand (a pocket knife will help you to cut away the material). Be sure to stop the engine and disconnect the spark plug wire before clearing the tines by hand.

⚠ WARNING

Before clearing the tines by hand, stop the engine, allow all moving parts to stop and disconnect the spark plug wire.

Remove the ignition key on electric start models.

Failure to follow this warning could result in personal injury.

Loading and Unloading the Tiller

⚠ WARNING

Loading and unloading the tiller into a vehicle is potentially hazardous and we don't recommend doing so unless absolutely necessary, as this could result in personal injury or property damage. However, if you must load or unload the tiller, follow the guidelines given next.

- Before loading or unloading, stop the engine, wait for all parts to stop moving, disconnect the spark plug wire and let the engine and muffler cool.
- The tiller is too heavy and bulky to lift safely by one person. Two or more people should share the load.
- Use sturdy ramps and manually (engine shut off) roll the tiller into and out of the vehicle. Two or more people are needed to do this.
- The ramps must be strong enough to support the combined weight of the tiller and any handlers. The ramps should provide good traction to prevent slipping; they should have side rails to guide the tiller along the ramps; and they should have a locking device to secure them to the vehicle.
- The handlers should wear sturdy footwear that will help to prevent slipping.
- Position the loading vehicle so that the ramp angle is as flat as possible (the less incline to the ramp, the better). Turn the vehicle's engine off and apply its parking brake.
- When going up ramps, stand in the normal operating position and push the tiller ahead of you. Have a person at each side to turn the wheels.
- When going down ramps, walk backward with the tiller following you. Keep alert for any obstacles behind you. Position a person at each wheel to control the speed of the tiller. Never go down ramps tiller-first, as the tiller could tip forward.
- Place wooden blocks on the downhill side of the wheels if you need to stop the tiller from rolling down the ramp. Also, use the blocks to temporarily keep the tiller in place on the ramps (if necessary), and to chock the wheels in place after the tiller is in the vehicle.
- After loading the tiller, prevent it from rolling by engaging the wheels in the WHEEL DRIVE position. Chock the wheels with blocks and securely tie the tiller down.

MAINTENANCE

WARNING

Before inspecting, cleaning or servicing the machine, shut off engine, wait for all moving parts to come to a complete stop, disconnect spark plug wire and move wire away from spark plug. Remove ignition key on electric start models.

Failure to follow these instructions can result in serious personal injury or property damage.

BEFORE EACH USE

- Check engine oil level
- Clean engine
- Check air filter element
- Check reduction gear oil

FIRST 2 HOURS OF BREAK-IN OPERATION

- Check drive belt tension
- Check nuts and bolts
- Change engine oil

EVERY 5 OPERATING HOURS

- Check engine oil level

EVERY 10 OPERATING HOURS

- Check drive belt tension
- Check nuts and bolts
- Change engine oil
- Lubricate tiller

EVERY FIRST MONTH OR FIRST 20 HOURS

- Change engine oil
- Replace reduction gear oil
- Clean air filter element

EVERY 30 OPERATING HOURS

- Check gear oil level in transmission
- Check tines for wear
- Check air pressure in tires (if unit has pneumatic tires)

EVERY 3 MONTHS OR EVERY 50 HOURS OF OPERATION

- Change engine oil
- Replace reduction gear oil
- Replace air filter element
- Clean spark arrester

EVERY YEAR OR EVERY 100 HOURS OF OPERATION

- Clean deposit cup
- Check/adjust spark arrester*
- Check/adjust idling
- Check/adjust valve clearance**
- Clean fuel tank and fuel filter**

EVERY TWO YEARS

- Check fuel line

EVERY 125 HOURS

- Clean up carbon from cylinder head piston**

NOTICE

- Change the engine oil after the first 2 hours of break-in operation.
- Change the engine oil more frequently in dusty conditions.

** These items should be replaced if replacement needed.

*** These items should be maintained and repaired by our authorized dealer, unless the owner has appropriate tools and is proficient with mechanical maintenance.

Tiller Lubrication

After every 10 operating hours, oil or grease the lubrication points as described below.

Use clean lubricating oil (#30 weight engine oil is suitable) and clean general purpose grease (grease containing a metal lubricant is preferred, if available).

- Remove the wheels, clean the wheel shaft and apply a thin coating of grease to the wheel shaft.
- Grease the back, front and sides of the depth regulator lever.
- Remove the tines and clean the tine shaft. Use a file or sandpaper to gently remove any rust, burrs or rough spots (especially around holes in shaft). Apply grease to ends of shaft before installing tines.
- Oil the threads on the handlebar height adjustment screws and the handlebar attaching screws.

Check for Oil Leaks

Before each use, check the tiller for signs of an oil leak — usually a dirty, oily accumulation either on the unit or on the floor.

A little seepage around a cover or an oil seal is usually not a cause for alarm. However, if the oil drips overnight, then immediate attention is needed. Ignoring an oil leak can result in severe transmission damage!

If a cover is leaking, check for loose screws. If the screws are tight, a new gasket or oil seal may be required.

If the leak is from around a shaft and oil seal, the oil seal probably needs to be replaced. See your authorized dealer or contact the factory for service or advice.

IMPORTANT: Never operate the tiller if the transmission is low on oil. Check the oil level after every 30 hours of operation and whenever there is any oil leakage.

Check Hardware

Check for loose or missing hardware after every 10 operating hours and tighten or replace (as needed) before reusing tiller.

Be sure to check the screws underneath the tiller hood that secure the transmission cover and the Depth Regulator Lever to the transmission.

Check Tire Pressure

(Models with pneumatic tires) Check the air pressure in both tires. The air pressure should be between 15 PSI and 20 PSI (pounds per square inch).

Keep both tires equally inflated to help prevent machine from pulling to one side.

Transmission Gear Oil Service

Check the transmission gear oil level after every 30 hours of operation or whenever you notice any oil leak. Operating the tiller when the transmission is low on oil can result in severe damage.

A. To Check the Transmission Gear Oil Level:

1. Check the gear oil level when the transmission is cool. Gear oil will expand in warm operating temperatures and this expansion will provide an incorrect oil level reading.
2. With the tiller on level ground, pull the Depth Regulator Lever all the way up.
3. Remove the dipstick/oil fill plug from the transmission housing and look inside the oil fill hole to locate the main drive shaft situated below the hole.

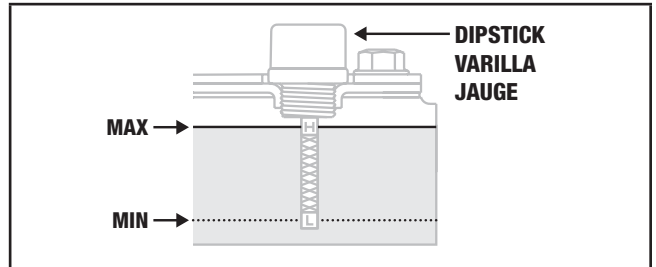
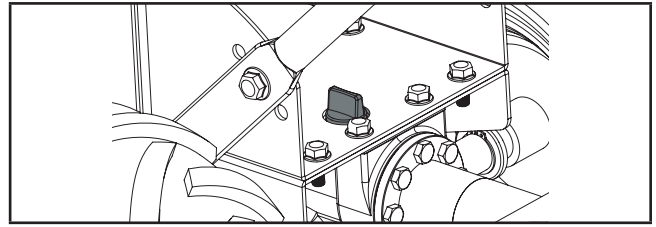

4. The gear oil level is correct if it falls between the L and H marks on the oil dipstick.
5. If the gear oil level is low, add GL-4 gear oil (SAE 85W-140 or SAE 140).
6. If the gear oil level is okay, securely replace the oil fill plug.

IMPORTANT: Do not operate the tiller if the gear oil level is low. Doing so will result in severe damage to the transmission components.

B. To Drain the Transmission Gear Oil:

The transmission gear oil does not need to be changed unless it has been contaminated with dirt, sand or metal particles.

1. Drain gasoline from the fuel tank or run the engine until the fuel tank is empty. See "DANGER" statement below.
2. Drain the oil from the engine.
3. Remove the left-side wheel.
4. Tilt the left-side wheel shaft into a drain pan and allow the gear oil to drain through the top of the transmission.

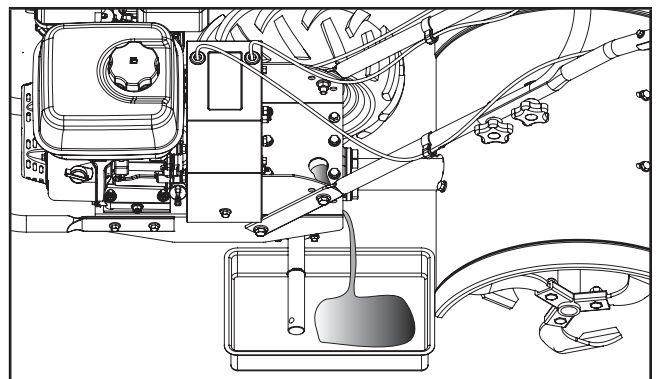

5. Reinstall the wheel.
6. Refill the transmission using GL-4 gear oil (SAE 85W-140 or SAE 140).
7. Refill the engine with engine oil and replenish the fuel tank with gasoline.

Tines

The tines will wear with use and should be inspected at the beginning of each tilling season and after every 30 operating hours. The tines can be replaced either individually or as a complete set. Refer to the parts list for tine identification and part numbers.

A. Tine Inspection:

With use, the tines will become shorter, narrower and pointed. Badly worn tines will result in a loss of tilling depth, and reduced effectiveness when chopping up and turning under organic matter.

B. Removing/Installing a Single Tine:

1. With the engine shut off and the spark plug wire disconnected, remove the M10×25 bolt, lock washer, flat washer and M10 nut that attach a single tine to a tine holder. If needed, use penetrating oil on the nuts.
2. When installing a single tine, be sure to position it so that its cutting edge (sharp) will enter the soil first as the tiller moves forward. Hand tighten completely.

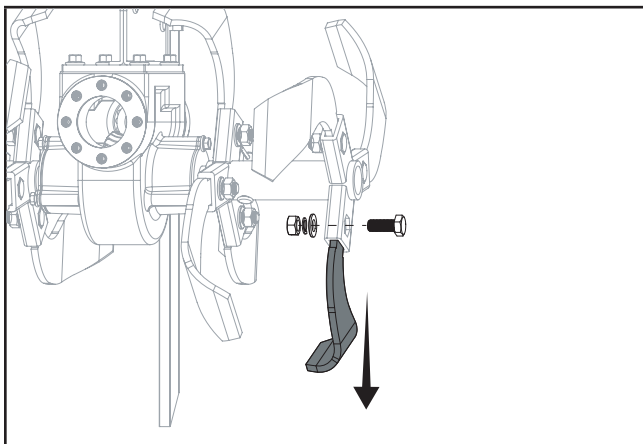

C. Removing/Installing a Tine Assembly:

1. A tine assembly consists of eight tines mounted on a tine holder.
2. If removing both tine assemblies, mark them “left” and “right” before removal. Remove (2) pins and (2) cotter pins that secure the tine assembly to the tine shaft. If necessary, use a rubber mallet to tap the tine assembly outward off the shaft.
3. Before reinstalling the tine assembly, inspect the tine shaft for rust, rough spots or burrs. Lightly file or sand, as needed. Apply a thin coat of grease to the shaft.
4. Install each tine assembly so that the cutting (sharp) edge of the tines will enter the soil first when the tiller moves forward.
5. Bend cotter pins once inserted to prevent the pins from coming out.

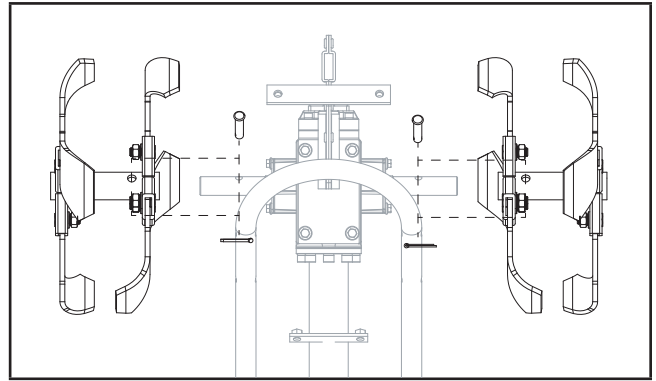

Checking and Adjusting Forward Drive Belt Tension

It is important to maintain correct tension on the forward drive belt. A loose belt will cause the tines and wheels to slow down — or stop completely — even though the engine is running at full speed. A too-tight belt can result in unintentional tine movement when the lever is in the Neutral (released) position.

- Check belt tension after the first two hours of break-in operation and after every 10 operating hours.
- At the end of each tilling season, check the belt for cracks, cuts or frayed edges, and replace it as soon as possible.

To Check Belt Tension:

1. Stop engine, wait for all parts to stop moving and disconnect spark plug wire.
2. With the forward and reverse lever in an open (released) position, measure and note the overall length of the cable spring by measuring from the outermost coil to the outermost coil.

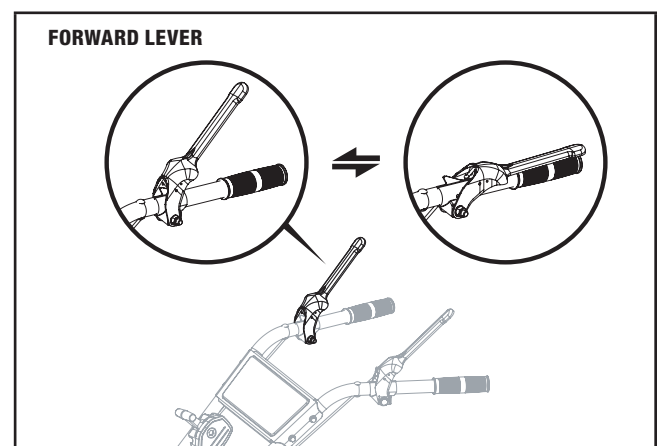

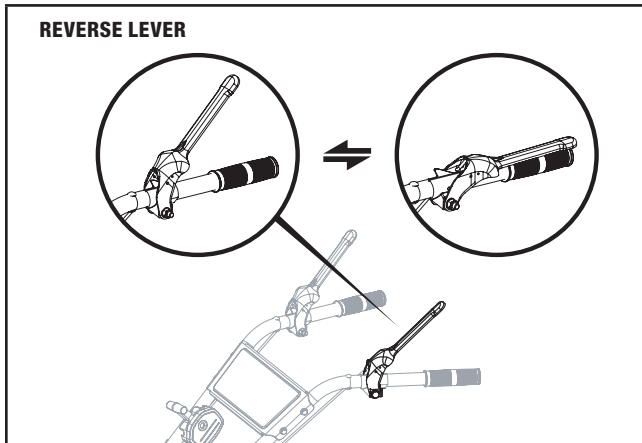

3. Squeeze the forward lever against the handlebar and re-measure the length of the coils. The belt tension is correct if this second measurement between 1/6 in. to 3/16 in. (2-5 mm) longer than the first measurement.
4. If the spring is too short (less than 1/16 in. [2 mm]), the tension is too loose. If the spring is too long (more than 3/16 in. [5 mm]), the tension is too tight.
5. To adjust the length of the spring.
 1. Release the forward lever.
 2. Un-thread the hex nut halfway up the adjustment screw.
 3. Unhook the top of the spring from the lever.
 4. Use pliers to prevent the adjuster from turning and turn the slotted screw located inside the spring clockwise (viewed from operator's position) to increase tension on the spring. Turn the screw counter-clockwise to decrease tension. Once adjusted, reattach the spring to the lever.
 5. Repeat Steps 2 and 3 to re-measure the length of the spring. When the second measurement is between 1/16 in. to 3/16 in. (2 to 5 mm) longer than the first measurement, re-tighten the hex nut against the top of the adjuster.

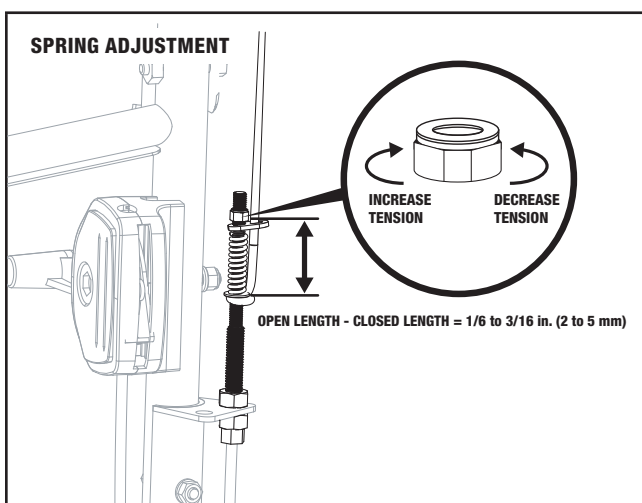

Replacement Belt Information

If the drive belt needs to be replaced, refer to the parts list for information. The procedure requires average mechanical ability and commonly available tools to change or replace.

	LENGTH (inches)	WIDTH (inches)
7PK612	24 in. \pm 0.24 in.	0.95 in. \pm 0.01 in.
5PK730	29 in. \pm 0.20 in.	0.70 in. \pm 0.02 in.

	LENGTH (mm)	WIDTH (mm)
7PK612	612.0 \pm 6.0 mm	24.20 \pm 0.30 mm
5PK730	730.0 \pm 5.0 mm	17.80 \pm 0.50 mm

Belt Tension Adjustment

Proper belt tension is critical to good performance. After 1/2 hour of operation, all cables may have to be adjusted due to initial stretch. Thereafter, check tension after every 2 hours of operation.

To increase belt tension:

1. Turn jam nut clockwise in 1/8 in. (3 mm) increments.
2. Check adjustment.

To decrease belt tension:

1. Turn jam nut counter-clockwise in 1/8 in. (3 mm) increments.
2. Check adjustment.
3. This procedure can be repeated until conduit adjustment bolts are fully adjusted. If no more adjustment can be made, belt may have to be replaced.

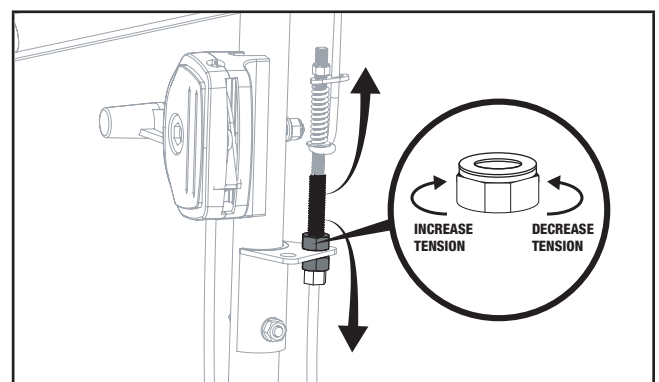

Change Forward/Reverse Belts

1. Turn off engine. Engine must cool completely before proceeding.
2. Remove spark plug wire and secure away from spark plug.
3. Reduce the belt tension by loosening the forward and reverse cable lower jam nut.
4. Remove the upper and lower belt guards.

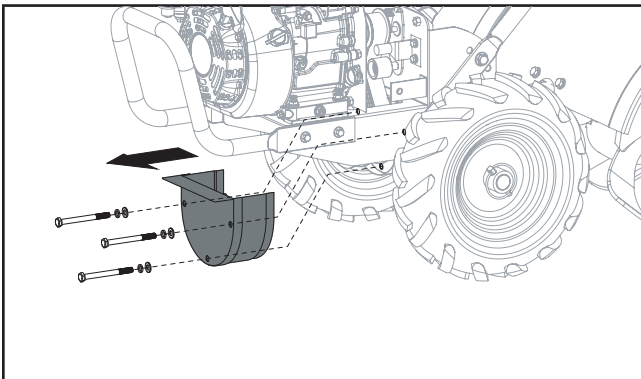
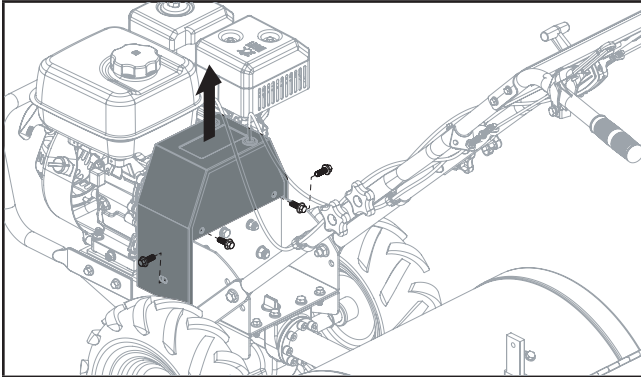

5. To remove the reverse drive belt:
 - a. Remove the reverse belt idler.
 - b. Slide the belt free of the reverse belt guides and engine pulley.
 - c. Pull belt down and away from the transmission pulley.

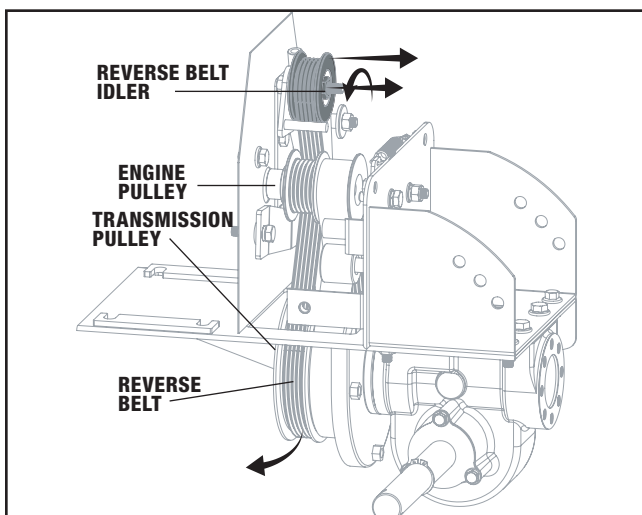

6. To remove the forward drive belt:

- a. Remove the two forward belt guide studs and forward belt idler assembly.

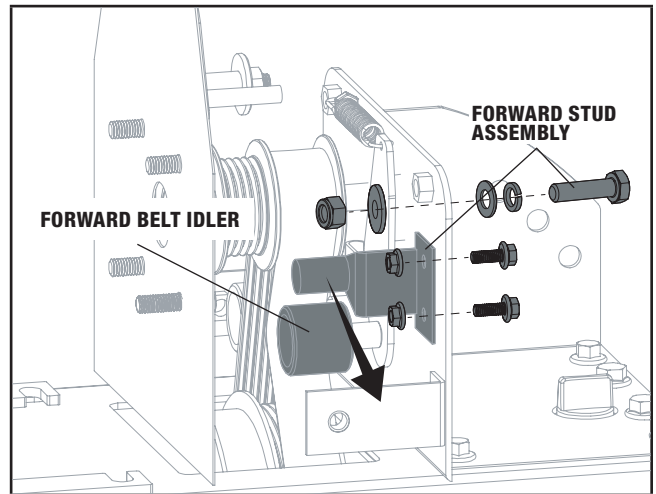

- b. Slide the belt free of the engine pulley.
- c. Pull the belt down and away from the transmission pulley.

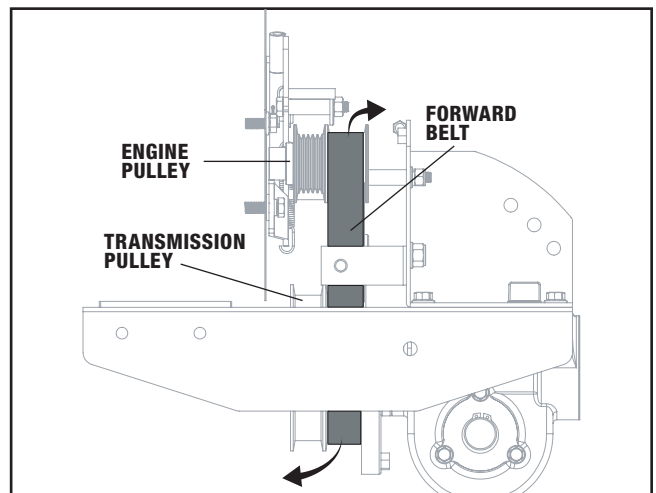

7. To install the reverse drive belt:
 - a. Insert the belt from underneath the unit and up around the reverse belt idler.
 - b. Place the lower loop of the belt around the rear portion of the transmission pulley.
 - c. Replace the reverse belt idler into the reverse belt idler bracket. The belt should not go around the engine pulley. Be sure the belt is inside of the reverse belt guide studs.

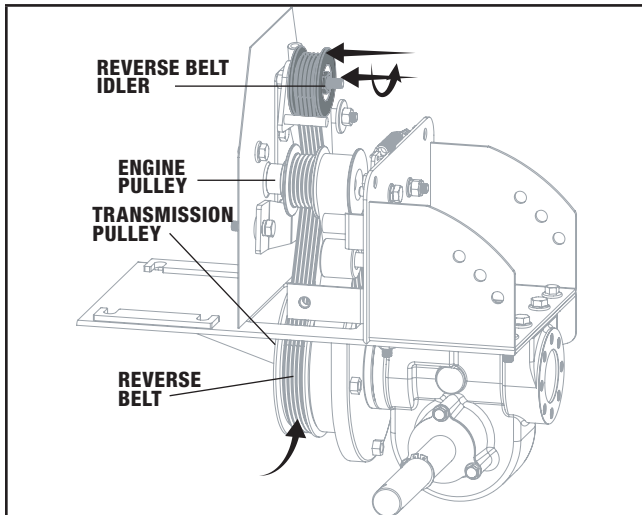

8. To install the forward drive belt:
- Insert the belt from underneath the unit and up around the rearward portion on the engine pulley.
 - Place the lower loop of the belt around the rearward portion of the transmission pulley.
 - Replace the forward belt guide studs and forward belt idler assembly.

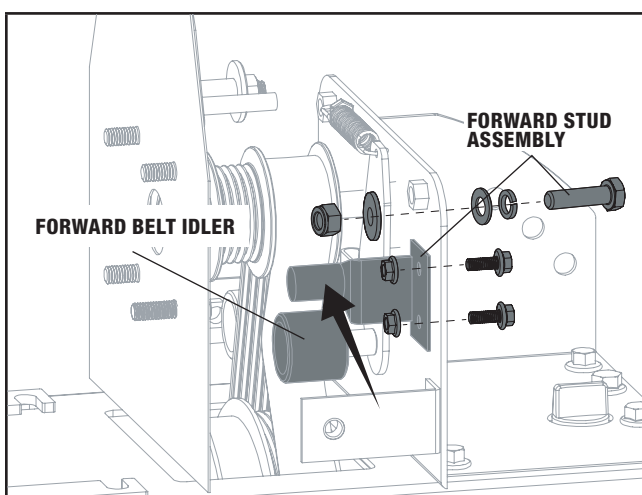
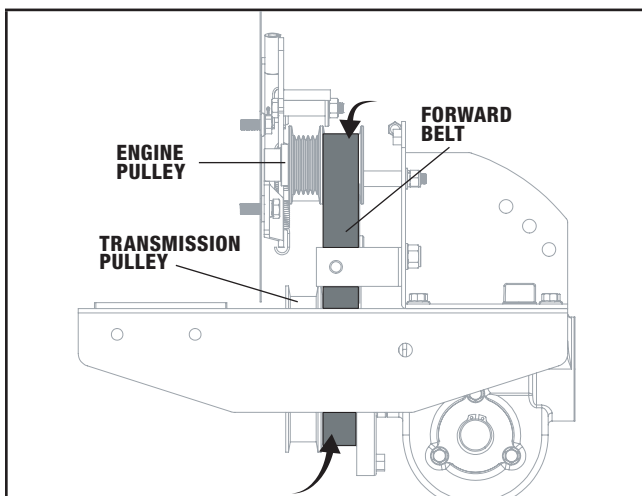

- Tighten the forward and reverse lower jam nut.
- Check the belt tension. The belts should be loose with the drive levers disengaged.
- Replace the upper and lower belt guards.
- Re-attach the spark plug wire to the spark plug.
- Follow Operating Instructions – start the engine and operate the forward drive lever to check for proper cable adjustment and belt tension. See the Belt Tension Adjustment section if cable adjustment is required.
- Start the engine and operate the reverse drive lever to check for proper cable adjustment and belt tension. See the Belt Tension Adjustment section if cable adjustment is required.

⚠ WARNING

The tines or wheels should not rotate with the engine running, the depth regulator set at transport height (lowest height) and the drive lever not engaged.

Engine Cleaning

Keeping the engine clean will help to ensure smooth operation and prevent damage from overheating. Refer to the Engine Owner's Manual for engine cleaning service intervals and instructions. Be sure that the muffler is cool before servicing the engine.

Air Cleaner Service

The air cleaner filters dirt and dust out of the air before it enters the carburetor. Operating the engine with a dirty, clogged air filter can cause poor performance and damage to the engine. Never operate the engine without the air cleaner installed. Inspect and service the air cleaner more often if operating in very dusty or dirty conditions. Refer to the engine Owner's Manual for air cleaner service intervals and instructions.

Engine Oil Service

Check the engine oil level before each use and after every five hours of continuous operation. Running the engine when it is low on oil will quickly ruin the engine.

It is recommended that you change the engine oil after every 10 hours of operation and even sooner when operating in extremely dirty or dusty conditions.

A. To Check the Engine Oil Level:

- Park the tiller on a level area and shut off the engine.
- Level the engine (use the Depth Regulator Lever to adjust the engine angle).

- Clean around the oil dipstick to prevent dirt from falling into the crankcase.
- On engines with a dipstick, remove it and wipe it clean. Reinsert the dipstick, tighten it securely, and remove it. Add oil as needed to bring the level up to the FULL mark. Wipe dipstick clean each time oil level is checked. Do not overfill. Tighten dipstick securely.

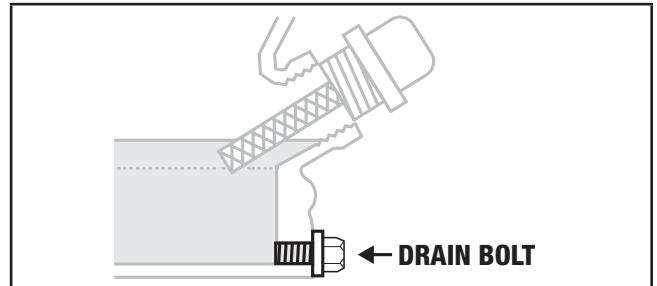
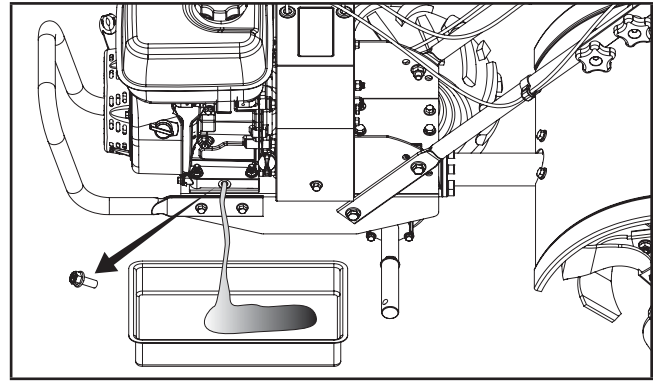
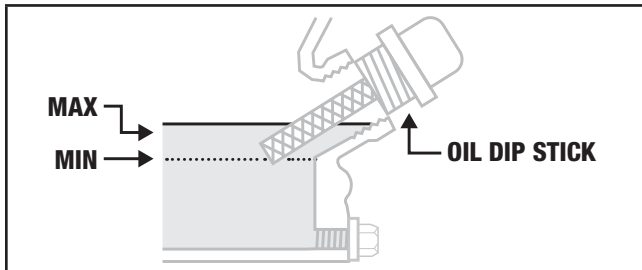

B. To Change the Engine Oil:

⚠ CAUTION

DO NOT attempt to crank or start the engine before it has been properly filled with the recommended type and amount of oil. Damage to the tiller as a result of failure to follow these instructions will void your warranty.

🗨 NOTICE

The recommended oil type is **10W-30 automotive oil**.

- Place tiller on a flat, level surface.
- Put the wheels in the WHEEL DRIVE position.
- Remove the left-side wheel and carefully prop up until ready to drain the engine oil.
- Tilt the left-side wheel shaft into a drain pan.
- Clean around the oil drain plug to prevent dirt from falling into the crankcase. Remove oil drain plug.
- Allow the engine oil to drain.
- Replace oil drain bolt.
- Reinstall the wheel.
- Refill the with engine oil through the dipstick with funnel and replenish the fuel tank with gasoline.

🗨 NOTICE

Once oil has been added, a visual check should show oil about 1-2 threads from running out of the fill hole.

If using the dipstick to check oil level, DO NOT screw in the dipstick while checking.

🗨 NOTICE

Check oil often during the break-in period. Refer to the [Maintenance](#) section for recommended service intervals.

⚠ CAUTION

The engine is equipped with a low oil shut-off and will stop when the oil level in the crankcase falls below the threshold level.

🗨 NOTICE

We consider the first 5 hours of run time to be the break-in period for the engine. During the break in period we recommend using standard automotive non-synthetic blended oils. After the break in period synthetic oil can be used but is not required. Adjusting throttle setting will increase/decrease engine speed helping to seat piston rings. Avoid bogging or lugging the engine down and avoid prolonged running at constant RPM. After the 5 hour break-in period, change the oil. Using synthetic oil does not increase the recommended oil change interval.

NOTICE

Weather will affect engine oil and engine performance. Change the type of engine oil used based on weather conditions to suit the engine needs.

NOTICE

Synthetic oil may be used after the 5 hour initial break-in period. Using synthetic oil does not increase the recommended oil change interval. Full synthetic 5W-30 oil will aid in starting in cold ambient <math><5^{\circ}\text{C}</math> (41° F).

Air Cleaner Maintenance

A dirty air cleaner can restrict air flowing into the carburetor. To keep the carburetor in good working conditions, please service the air cleaner periodically. If operating the engine in extremely dusty area, servicing should be done more often.

WARNING

Never clean the air cleaner element with gasoline or low flash-point detergents, an explosion may happen.

NOTICE

Never run the engine without an air cleaner. Dirty air entering the engine can speed up engine wear.

1. Remove the air cleaner cover and take the element out.
2. Paper element: Wash the element with home detergents and warm water (or non-flammable or high flash-point cleansing solvents) and dry.
Foam element: Soak in clean engine oil until saturated. Squeeze out excess oil; otherwise, the engine will smoke when starting.
3. Clean the air cleaner cover and inner surface with a damp cloth, be careful not to allow dust to enter the carburetor.
4. Reinstall the element and reinstall the air cleaner cover.

Spark Plug Service

Spark plug type: F6RTC/F6TC/F7RTC/F7TC

For normal engine operation, ensure the spark plug gap is correct and check for carbon deposit around the spark plug.

1. Remove the spark plug cap.
2. Clear away dirt around the spark plug base.
3. Dismantle the spark plug with a spark plug wrench.
4. Visually check the spark plug. Clean with a steel brush. If the insulator is damaged, replace the spark plug.

5. Measure the spark plug clearance with a spark plug gap gauge. The clearance should be 0.7-0.8 mm. If adjustment is necessary, bend the side electrode carefully.
6. Check if the spark plug gasket is in good condition. To prevent cross threading, screw in by hand.
7. Screw in the spark plug to the bottom first by hand and then screw in by a spark plug wrench and compress the gasket.
 - 7a. If a new spark plug is used, twist another 1/2 turn after compressing the gasket.
 - 7b. If reinstalling a used spark plug, only twist another 1/8-1/4 turn.

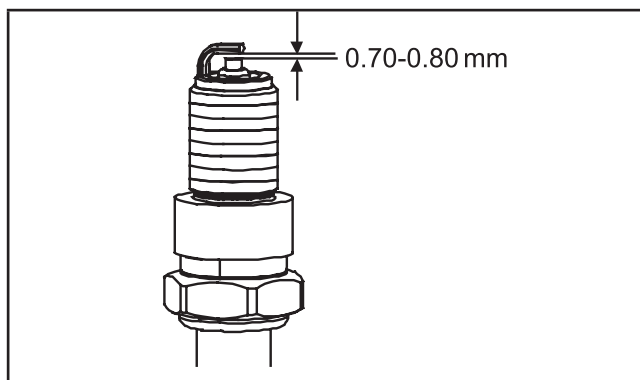
**WARNING**

Don't touch the muffler when the engine is running or hot.

NOTICE

The spark plug must be tightened securely, or it may become very hot and damage the engine.

Spark Arrester Screen Service

If the engine muffler is equipped with a spark arrester screen, remove and clean it according to the service intervals.

TRANSPORTATION AND STORAGE

Transport with the fuel valve turned the "OFF" position. Transport or store the engine when it is cool to avoid getting burns or starting a fire.

NOTICE

Do not tilt the engine to avoid fuel spill. Spilled fuel or fuel vapor may ignite and cause fire.

Off-Season Storage

When the tiller won't be used for an extended period, prepare it for storage as follows:

1. Make sure the storage area is dry and free of dust.
2. Clean the tiller and engine.
3. Do routine tiller lubrication and check for loose parts and hardware.
4. Turn the fuel valve to "OFF" position, set a proper container under the carburetor.
5. Drain the oil out of the gasoline engine.
6. Remove the spark plug. Place about a spoon of fresh engine oil into the cylinder. Crank the engine to distribute engine oil evenly.
7. Reinstall the spark plug.
8. Store unit in a clean, dry area.
9. Never store the tiller with fuel in the fuel tank in an enclosed area where gas fumes could reach an open flame or spark, or where ignition sources are present (space heaters, hot water heaters, furnaces, etc.)
10. Loosen the oil drain bolt and completely drain the gasoline out of the carburetor into a proper container and screw the oil drain bolt down. Remove the sediment bowl after closing fuel cock, and completely pour the gasoline out the sediment bowl. Finally reinstall the sediment bowl back and screw it down.

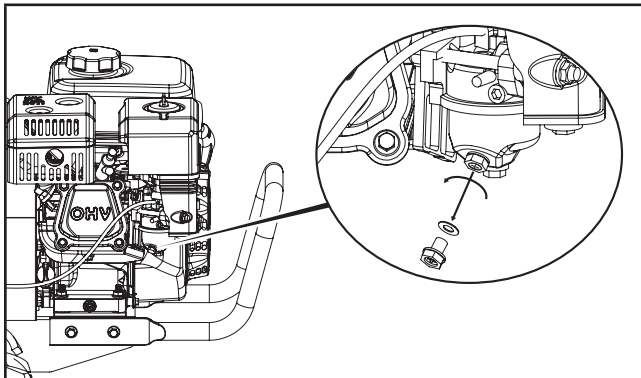

⚠ WARNING

Fuel is extremely flammable and explosive under certain conditions. Keep smoke, fire and spark away from operating site.

Removing from Storage

1 MONTH

- No repair needed.

1-2 MONTHS

- Drain the used gasoline and add fresh gasoline.

2 MONTHS TO 1 YEAR

- Drain the used gasoline and add fresh gasoline.
- Drain the gasoline out of the carburetor cup.
- Drain the gasoline out of the sediment bowl.

OVER 1 YEAR

- Drain the used gasoline add fresh gasoline.
- Drain the gasoline out of the carburetor cup.
- Drain the gasoline out of the sediment bowl.

SPECIFICATIONS

Tiller Specifications

Model	100380
Tine Diameter	13.8 in. (350 mm)
Tilling Width (in.)	19 in. (480 mm)
Tilling Depth (in.)	8 in. (203 mm)
Tilling Depth Adjustments	1.6 in. (41 mm) Increments
Wheel Diameter	13 in. (330 mm)
Transmission Gear Oil	API rated GL-4 or GL-5
..... Viscosity of SAE 140, SAE 85W-140 or SAE 80W-90	
Net Weight	160.9 lb. (73 kg)
Length	58.7 in. (149 cm)
Width	19.7 in. (50 cm)
Height	49.6 in. (126 cm)

Engine Specifications

Displacement	212 cc
Type	4-Stroke OHV
Fuel Capacity	0.9 gal. (3.2 L)
Oil Capacity	0.6 qt. (0.6 L)
Oil Type	10W-30

NOTICE

Weather will affect engine oil and engine performance.
Change the type of engine oil used based on weather conditions to suit the engine needs.

Fuel Specifications

Use regular unleaded gasoline with a minimum octane rating of 85 and an ethanol content of less than 10% by volume. DO NOT USE E15 or E85. DO NOT OVERFILL.

Parts Diagram

Control Subassembly

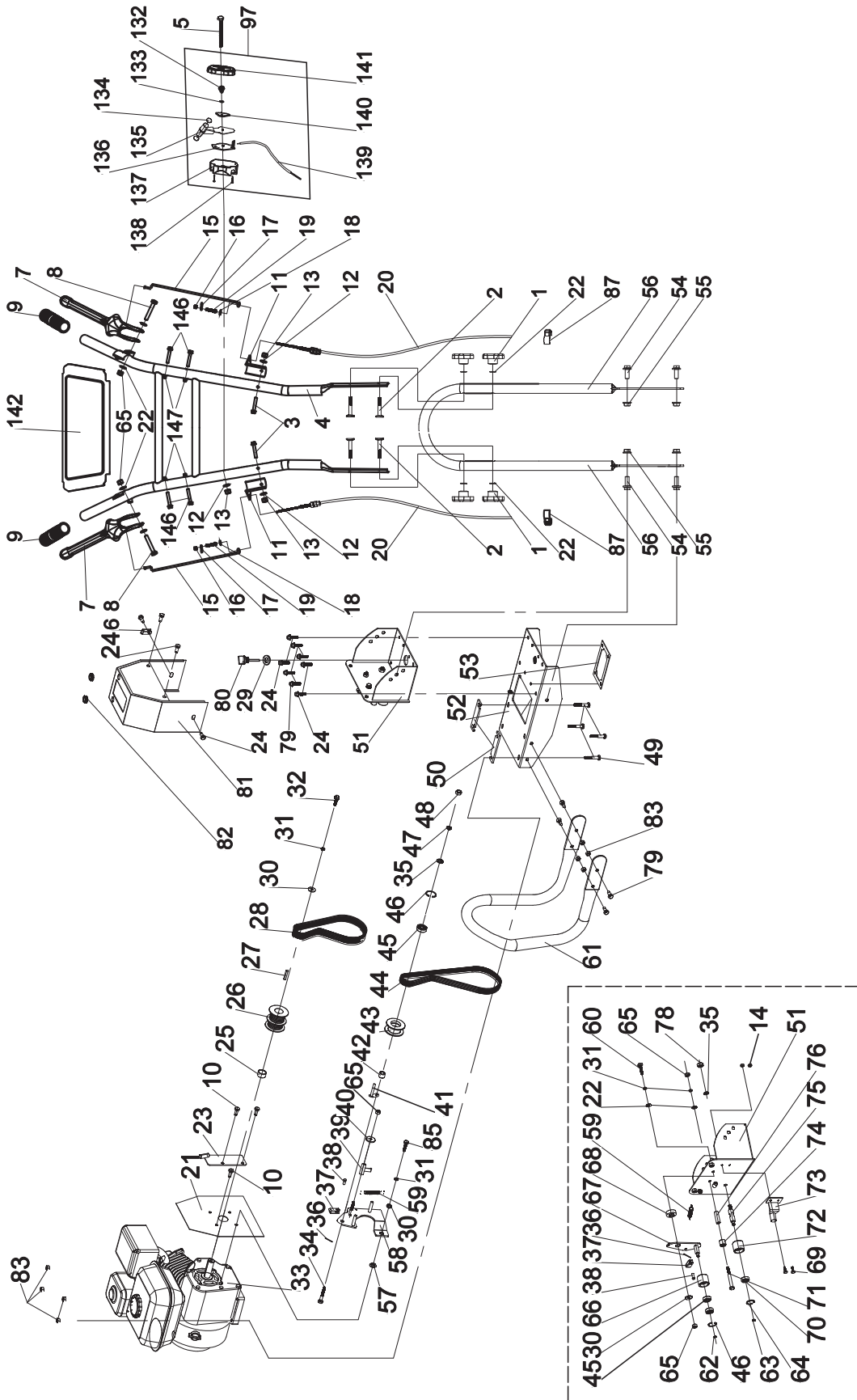

Tine and Fender Subassembly

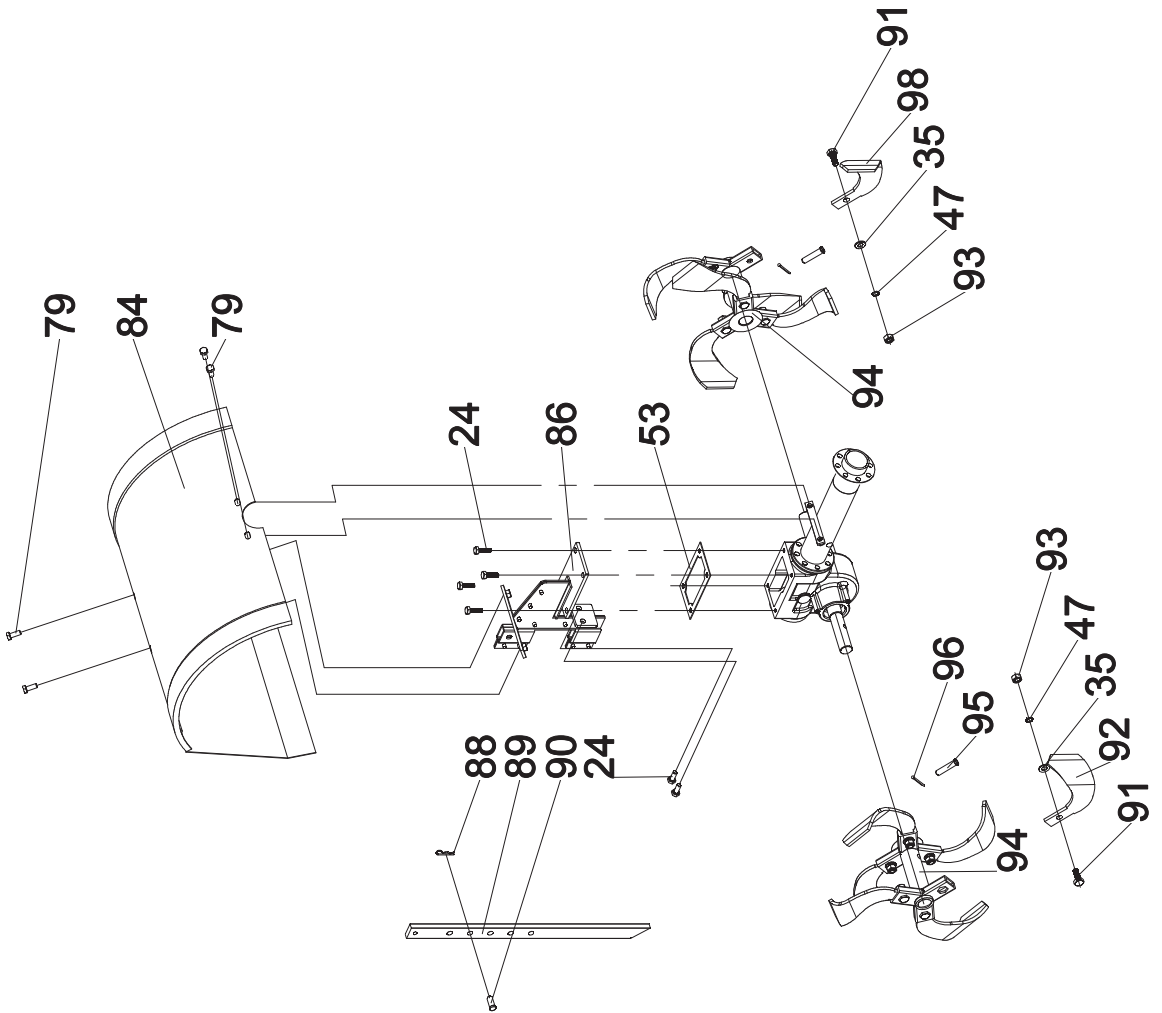

Transmission Subassembly

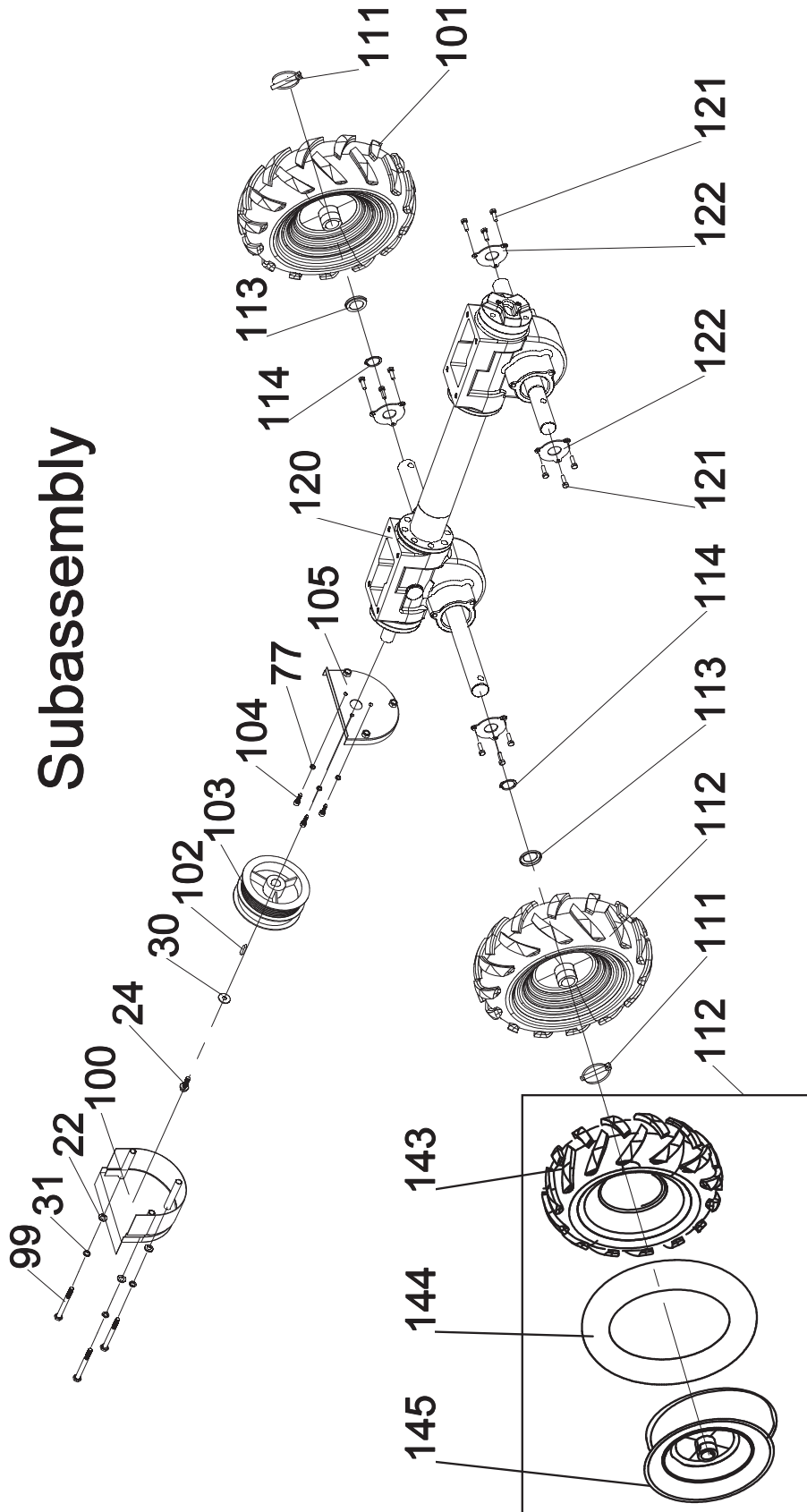

Transmission Case Subassembly

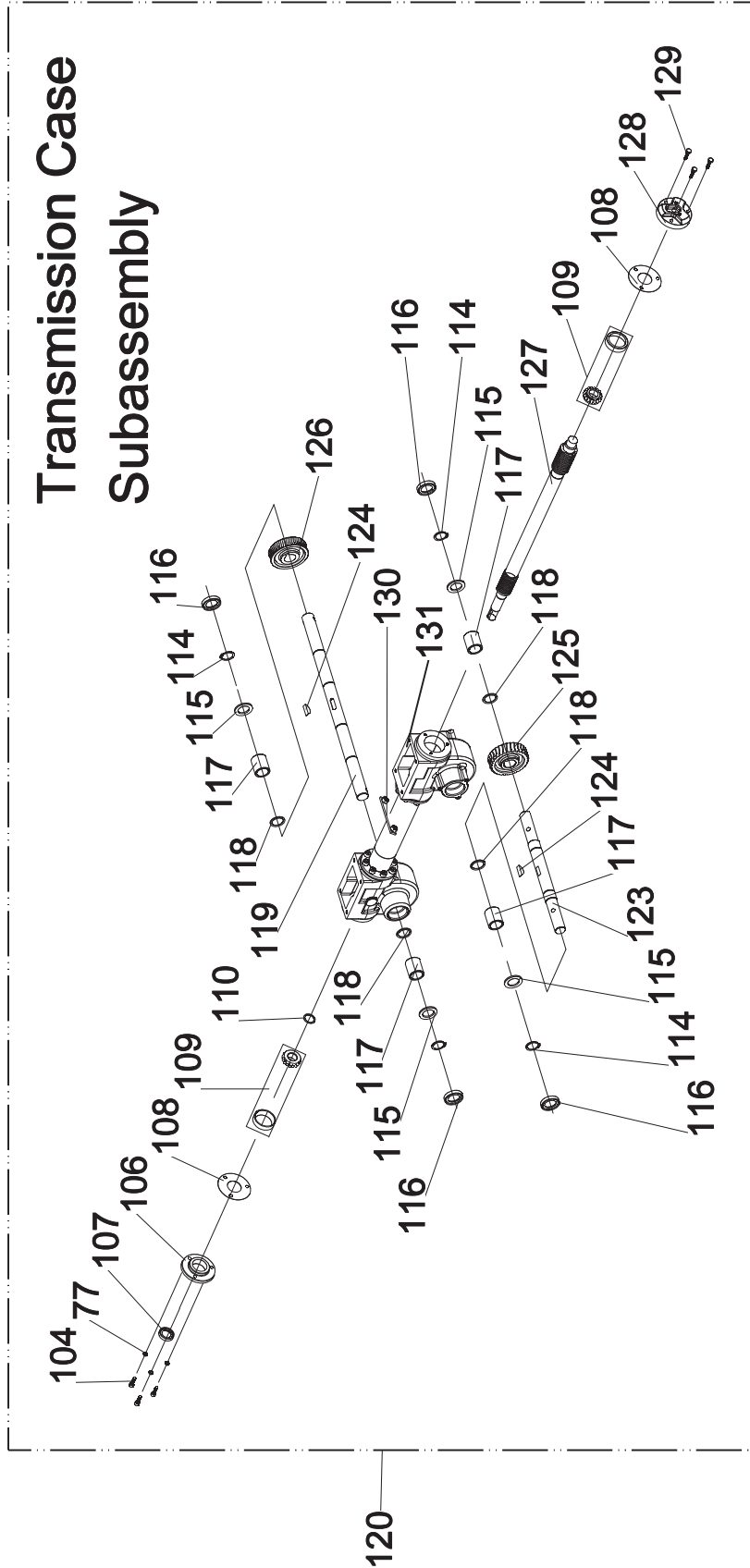

Parts List

#	Part Number	Description	Qty.
1	100380-001	Handle Bar Knob Nut	4
2	100380-002	Fan-shaped Screw M8 × 50	4
3	100379-026	Flange Bolt M6 × 35	2
4	100380-003.2	Handle Bar Assembly, Black	1
5	100379-009	Bolt M6 × 60	1
6	100380-004	Wire Nip	1
7	100380-005.2	Clutch Lever, Black	2
8	100380-006	Bolt M8 × 25	2
9	100380-007	Handle cover	2
10	100379-033	Flange Bolt M8 × 16	3
11	100380-008	Cable Fixing Plate	2
12	100379-019	Flat Washer Ø6	3
13	100379-020	Locknut M6	3
14	100379-099	Flange Locknut M6	2
15	100380-009	Clutch Rod	2
16	100380-010	Locknut M5	2
17	100380-011	Pull Pole Protector	2
18	100380-012	Flat Washer Ø5 × Ø12 × 1	2
19	100380-013	Spring	2
20	100380-014	Clutch Cable Assembly	2
21	100380-015.48	Big Belt Cover Protector, Yellow	1
22	100379-016	Flat Washer Ø8	13
23	100380-016	The Backward Pull Plate Assembly	1
24	100380-017	Flange Bolt M8 × 20	15
25	100380-018	Small Belt Wheel Shaft Bushing	1
26	100380-019	Small Belt Wheel	1
27	100380-020	Flat Key 4.78 × 5 × 35	1
28	100380-021	Belt 7PK612	1
29	100380-022	Oil Dipstick Gasket	1
30	100380-023	Flat Washer Ø8 × Ø22 × 2	4
31	100379-029	Spring Washer Ø8	7
32	100379-076	Bolt 5/16, 1"-24	1
33	100379-024	Gasoline Engine	1
34	100380-024	Bolt M10 × 50	1
35	100379-040	Flat Washer Ø10	12
36	100380-025	Pin Ø1.5 × 20	2
37	100380-026	Cable Clip	2

#	Part Number	Description	Qty.
38	100380-027	Pin Roll Ø6 × 16	2
39	100380-028	Shaft Bushing 1	1
40	100379-057	Flat Washer Ø8 × Ø28 × 3	1
41	100380-029	Belt Buckle	1
42	100380-030	Reverse Tension Sleeve	1
43	100380-031	Reverse Tension Wheel	1
44	100380-032	Belt 5PK730	1
45	100380-033	Bearing 6200	3
46	100380-034	Circlip 30	2
47	100379-111	Spring Washer Ø10	13
48	100380-035	Nut M10	1
49	100379-093	Flange Bolt M8 × 45	4
50	100380-036	Ajustable Plate	2
51	100380-037.48	Handle Seat Assembly, Yellow	1
52	100380-038.48	Engine Seat Assembly, Yellow	1
53	100380-039	Gaskets	2
54	100380-040	Flange Bolt M10 × 25	4
55	100380-041	Flange Locknut M10	2
56	100380-042.2	Handle Arm, Black	1
57	100380-043	Tension Bushing	1
58	100380-044	Tension Seat Plate Assembly	1
59	100380-045	Spring	2
60	100380-046	Bolt M8 × 30	1
61	100380-047.2	Bumper, Black	1
62	100380-048	Circlip 10	1
63	100379-064	Circlip 8	1
64	100379-065	Circlip 24	1
65	100379-015	Locknut M8	5
66	100380-049	Forward Tension Wheel	1
67	100380-050	Clutch Arm Assembly	1
68	100380-051	Tension Bushing	1
69	100379-108	Flange Bolt M6 × 16	2
70	100379-063	Bearing 628	1
71	100380-052	Bolt M8 × 70	1
72	100380-053	Tension Wheel	1
73	100380-054	Retaining Stem Components Belt	1
74	100380-055	Belt Block Set 2	1

#	Part Number	Description	Qty.
75	100380-056	Tension Wheel Pole	1
76	100380-057	Belt Block Set 1	1
77	100380-058	Spring Washer Ø6	3
78	100380-059	Locknut M10	1
79	100379-048	Flange Bolt M8 × 25	12
80	100380-060	Oil Dipstick	1
81	100380-061.48	Big Belt Cover Protector, Yellow	1
82	100380-062	Cable Protector	2
83	100379-032	Flange Locknut M8	8
84	100380-063.48	Safety Guard Assembly, Yellow	1
85	100379-080	Bolt M8 × 25	1
86	100380-064.2	Depth Regulator Seat Assembly, Black	1
87	100380-065	Ply-yarn Drill	2
88	100379-042	B Uncork Pin Ø2 × 37	1
89	100380-066.2	Safety Guard, Black	1
90	100380-067	Pin Roll Ø10 × 25	1
91	100379-113	Bolt M10 × 1 × 25	12
92	100380-068.2	Left Tillage Blade, Black	6
93	100379-110	Nut M10 × 1	12
94	100380-069.2	Tool Carrier Assembly, Black	2
95	100380-070	Pin Roll Ø10 × 42	2
96	100380-071	Pin Ø3 × 30	2
97	100380-072	Throttle Switch	1
98	100380-073.2	Right Tillage Blade, Black	6
99	100380-074	Bolt M8 × 90	3
100	100380-075.48	Small Belt Cover Assembly, Yellow	1
101	100380-076.48	Wheel, Right, 13inch, Yellow	1
102	100380-077	Flat Key 5 × 5 × 25	1
103	100380-078	Big Belt Wheel	1
104	100379-005	Screw M6 × 20	3
105	100380-079.48	Small Belt Cover Protector Assembly, Yellow	1
106	100380-080.2	Front Cover, Black	1
107	100380-081	Framework Oil Seal Ø20 × Ø32 × 6	1
108	100380-082	Gaskets 1	2
109	100380-083	Cone Needle Bearing 7204E	2

#	Part Number	Description	Qty.
110	100380-084	Adjusting Shim	1
111	100380-085	Lock Pin	2
112	100380-086.48	Wheel, Left, 13inch, Yellow	1
113	100380-087	Wheel Shaft Cap	2
114	100380-088	Circlip 25	6
115	100380-089	Locating Washer	4
116	100380-090	Framework Oil Seal Ø25 × Ø40 × 7	4
117	100380-091	Output Shaft Bearing	4
118	100380-092	Adjustable Washer	4
119	100380-093	Wheel Shaft	1
120	100380-095.2	Cabinet Assembly, Black	1
121	100380-096	Flange Bolt M6 × 12	12
122	100380-097	Oil Seal Cap	4
123	100380-098	Tiller Shaft	1
124	100380-099	Semicircle Key	2
125	100380-100	Tiller Worm Wheel	1
126	100380-101	Worm Wheel	1
127	100380-102	Worm Wheel Shaft	1
128	100380-103.2	Rear Cap, Black	1
129	100380-104	Screw M6 × 25	3
130	100380-105.2	Front Cover Fixing Plate, Black	1
131	100380-106.2	Box, Black	1
132	100379-013	Rivet	1
133	100379-123	Saddle Elastic Washer Ø10	1
134	100379-122	Plug	2
135	100379-112.1	The Accelerator Components In Hand, Black	1
136	100379-120	The Throttle Switch Fixed Plate	1
137	100379-023	Right Throttle Switch Box	1
138	100379-012	Self-tapping Screw M3 × 20	2
139	100379-014	Throttle Cable	1
140	100379-121	Positioning Plate	1
141	100379-021	Left Throttle Switch Box	1
142	100380-106.1	Logo Plate, Black	1
143	100380-107	tyre casing	2
144	100380-108	tyre tube	2
145	100380-109.48	Wheel boss, Yellow	2

#	Part Number	Description	Qty.
146	100380-110.2	Flange Bolt M6 × 35, Black	4
147	100380-111.2	Flange Locknut M6, Black	4

Engine Parts Diagram

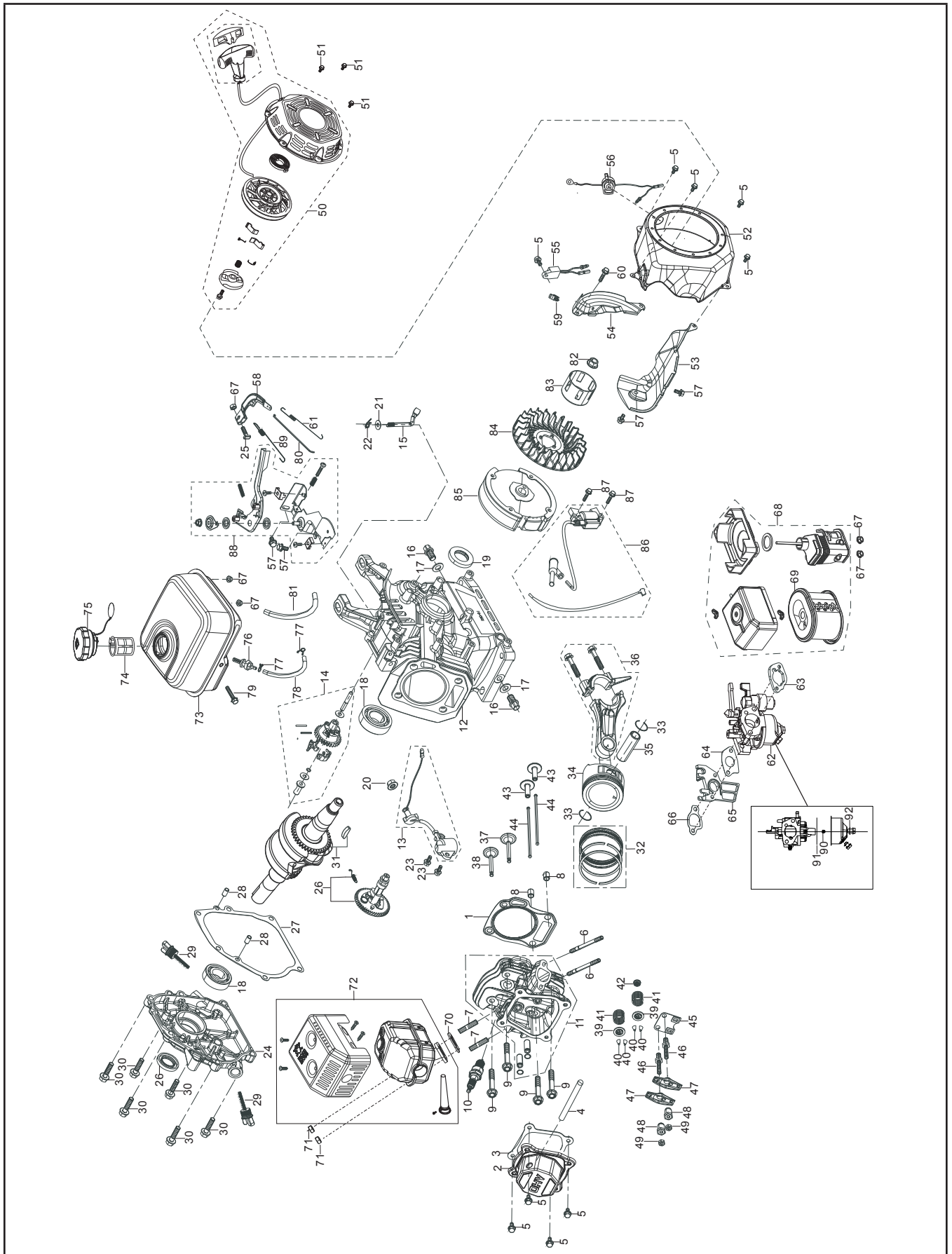

Engine Parts List

#	Part Number	Description	Qty.
1	12131-Z950110-0000	Gasket, Cylinder Head	1
2	12410-Z440110-0099	Cover Subassembly, Cylinder Head	1
3	12004-Z440110-0000	Gasket, Cylinder Head Cover	1
4	17004-Z010310-0000	Tube, Breather, Ø8 × Ø12 × 90	1
5	90001-0612-01	Bolt, M6 × 12	9
6	90204-Z010310-0000	Stud, M6 × 113	2
7	90203-Z010110-0000	Stud, M8 × 34	2
8	90502-1114-00	Pin, d=11 L=14	2
9	12003-Z010110-0000	Bolt, Cylinder Head, M8 × 60	4
10	30010-Z010110-0000	Plug, Spark, M14 × 1.25-6e L=81, F6RTC	1
11	12140-Z810210-0000	Head Subassembly, Cylinder	1
12	11310-Z530420-0099	Crankcase Subassembly	1
13	37060-Z010120-0000	Sensor, Engine Oil	1
14	16400-Z010110-0000	Gear Assembly, Governor	1
15	16061-Z010110-0000	Arm, Governor	1
16	11007-Z010110-0000	Bolt, Drain Plug, M10 × 1.25 × 15	2
17	90408-Z010110-0000	Washer, Ø10 × 1.25 × Ø15	2
18	90547-0205-CL	Bearing, Ø25 × Ø52 × 15	2
19	90682-Z300110-0000	Seal, Oil d=25 D=41.25 b=6	2
20	90305-Z010210-01	Nut, M10	1
21	90408-Z010210-0000	Washer, Ø6.2 × Ø15 × 0.6	1
22	90501-Z010110-0000	Cotter Pin, Ø1.2 L=26	1
23	90001-0614-01	Bolt, M6 × 14	2
24	11411-Z440310-0000	Cover, Crankcase	1
25	16072-Z010110-0000	Bolt, Governor Support, M6 × 21	1
26	14200-530210-0099	Camshaft Assembly	1
27	11001-Z440110-0000	Gasket, Crankcase	1
28	90502-0912-00	Pin, d=9 L=12	2
29	15010-Z290110-0B00	Dipstick Subassembly, Oil	2
30	90001-0832-01	Bolt, M8 × 32	6

#	Part Number	Description	Qty.
31	13300-Z533210-0000	Crankshaft Assembly	1
32	13200-Z140210-0099	Piston Ring Assembly	1
33	13122-Z010110-0000	Clip, Piston Pin	2
34	13111-Z140220-0099	Piston	1
35	13121-Z010110-0000	Pin, Piston	1
36	13010-Z440210-0099	Rod, Connecting	1
37	12110-Z810110-0099	Intake Valve	1
38	12110-Z810120-0099	Exhaust Valve	1
39	12112-Z810210-0000	Seat, Valve Spring	2
40	12109-Z810110-0000	Lock Clamp, Valve	4
41	12103-Z010110-0000	Spring, Valve	2
42	12101-Z810210-0000	Guide, Seal	1
43	14081-Z040110-0000	Tappet, Valve	2
44	14071-Z440110-0000	Lifter, Valve	2
45	14090-Z010110-0000	Plate Subassembly, Lifter Stopper	1
46	14313-Z010110-0000	Bolt, Valve Adjusting	2
47	14311-Z010110-0000	Rocker, Valve	2
48	14314-Z010110-0000	Nut, Valve Adjusting	2
49	14312-Z010110-0000	Nut, Valve Lock	2
50	28200-Z300110-H600	Starter Assembly, Recoil, Black	1
51	90001-0608-01	Bolt, M6 × 8	3
52	28110-Z010410-0B00	Shroud, PMS 109 C	1
53	19304-Z010610-0000	Shroud, Cylinder Body	1
54	19340-Z010120-0000	Shield, Lower	1
55	37050-Z010210-0000	Protector, Oil	1
56	35540-Z060140-Q200	Switch Subassembly, Stop Engine	1
57	90001-0610-01	Bolt, M6 × 10	4
58	16070-Z010110-0000	Support Subassembly, Governor	1
59	90740-Z010110-0000	Collar, Ø15	1
60	90001-0616-01	Bolt, M6 × 16	1
61	16012-Z010110-0000	Spring, Throttle Valve Returning	1
62	16100-Z530610-0709	Carburetor Assembly	1
63	17001-Z010210-0000	Gasket, Air Cleaner	1
64	16001-Z010110-0000	Gasket, Carburetor	1
65	16003-Z010110-0000	Plate, Carburetor Insulator	1
66	16002-Z050110-0000	Gasket, Carburetor Insulator	1
67	90305-0600-31	Nut, M6	5

#	Part Number	Description	Qty.
68	17100-Z010210-0000	Air Cleaner Assembly, Black	1
69	17150-Z010110-0000	Element, Air Cleaner	1
70	18001-Z440110-0000	Gasket, Exhaust Outlet	1
71	90303-0800-31	Nut, M8	2
72	18100-Z012410-H300	Muffler Assembly, Black	1
73	16620-Z440410-H600	Fuel Tank, Black	1
74	16652-Z010710-0000	Strainer, Fuel	1
75	16730-Z440210-LK00	Fuel Tank Cap, Black	1
76	16680-Z010110-0000	Outlet Subassembly, Fuel Tank Oil	1
77	90740-Z010210-0000	Collar, Ø7.5	2
78	90686-Z010710-0000	Tube, Fuel, Ø4.5 × Ø8.5 × 160	1
79	90001-0630-01	Bolt, M6 × 30	1
80	16062-Z010110-0000	Rod, Governor	1
81	30431-Z010110-0000	Jacket, Rubber	1
82	13501-Z010110-0000	Nut, Flywheel, M14 × 1.5	1
83	28002-Z010310-0000	Pulley, Starter	1
84	19352-Z440110-0000	Cooling Fan	1
85	13510-Z440410-0000	Flywheel Subassembly	1
86	30400-Z440110-0100	Coil, Ignition	1
87	90001-0625-01	Bolt, M6 × 25	2
88	16520-Z010430-0001	Control Assembly ,Throttle	1
89	16063-Z050510-0000	Spring, Governor	1
90	16161-Z030310-0000	Main Jet, H128 × 0.91, Standard	1
	16161-Z010310-0000	Main Jet, H128 × 0.94, Altitude 3000-6000 feet	/
	16161-Z050210-0000	Main Jet, H128 × 0.97, Altitude 6000-8000 feet	/
91	16112-Z010110-0000	Seal Ring, Float	1
92	90681-Z010510-0000	Seal Ring	1

TROUBLESHOOTING

Problem	Cause	Solution
Engine does not start	Spark plug wire disconnected.	Reconnect wire.
	Engine Throttle Control Lever incorrectly set.	Put lever in START position.
	Fuel tank empty.	Add fuel.
	Choke control (if so equipped) in incorrect position.	Move to CHOKE position.
	Stale gasoline.	Drain fuel and add fresh fuel.
	Dirty air filter.	Clean or replace filter.
	Defective or incorrectly gapped spark plug.	Inspect spark plug.
	Carburetor out of adjustment.	Contact Technical Support Team.
	Misadjusted throttle control.	Contact Technical Support Team.
	Dirt or water in fuel tank.	Contact Technical Support Team.
Engine runs poorly	Defective or incorrectly gapped spark plug.	Inspect spark plug.
	Dirty air filter(s).	Clean or replace.
	Carburetor out of adjustment.	Contact Technical Support Team.
	Stale gasoline.	Replace with fresh gasoline.
	Dirt or water in fuel tank.	Contact Technical Support Team.
Engine overheats	Engine cooling system clogged.	Clean air cooling area.
	Carburetor out of adjustment.	Contact Technical Support Team.
	Oil level is low.	Check oil level.
Engine does not shut off	Misadjusted throttle control or ignition switch.	Contact Technical Support Team.
Wheels and Tines will not turn	Improper use of controls.	Review controls section.
	Worn, broken, or misadjusted drive belt(s).	See "Checking and Adjusting Forward Drive Belt Tension" or "Belt Tension Adjustment".
	Internal transmission wear or damage.	Contact local dealer or the factory.
	Bolt loose in transmission pulley.	Tighten bolt.
Tines turn, but wheels don't	Wheel Drive Pins not in WHEEL DRIVE.	See "Wheel Drive Pins".
	Bolt loose in transmission pulley.	Tighten bolt.
	Internal transmission wear or damage.	Contact Technical Support Team.
Wheels Turn, but tines don't	Tine holder mounting hardware missing.	Replace hardware.
	Bolt loose in transmission pulley.	Tighten bolt.
	Internal transmission wear or damage.	Contact Technical Support Team.
Poor tilling performance	Worn tines.	See "Tines" section.
	Improper Depth Regulator setting.	See "Depth Regulator Lever Adjustment".
	Incorrect throttle setting.	Adjust throttle on engine or speed control on handelbar to highest setting.
	Forward Drive Belt slipping.	See "Checking and Adjusting Forward Drive Belt Tension" or "Belt Tension Adjustment".

Difficulty Starting Engine (Recoil)

Problem	Cause	Solution	
Something wrong with the fuel system: fuel supply is not smooth or no fuel supply	There is no enough fuel in fuel tank and fuel cock is closed.	Fill fuel, open fuel cock.	
	Air vent in the fuel filler cap is clogged.	Dredge air vent.	
	Fuel cock is clogged.	Clean first and then dredge.	
	Improper or clogged main oil flow hole.	Readjust or clean. Blow to clear through.	
	Needle valve is not closed properly or start hole is clogged.	Dismantle needle valve and repair, clean. Blow to get through.	
	Float is damaged or sticking.	Repair float.	
	Fuel is too filthy or deteriorated.	Replace.	
	There is water in fuel.	Replace.	
	Too much fuel in engine.	Drain extra fuel. Dry up spark plug electrodes.	
	Wrong fuel brand.	Select proper fuel brand corresponding with the requirements.	
No spark	Too much carbon deposit and dirt around electrodes.	Clear carbon deposits.	
	Too much carbon deposit and dirt around electrodes.	Replace spark plug.	
	Too much carbon deposit and dirt around electrodes.	Adjust to proper value.	
Abnormal cylinder compression	Piston ring is at its wear limit.	Replace.	
	Piston ring is broken.	Replace.	
	Piston ring is sticking.	Clear up carbon fouling.	
	Spark plug is not installed tightly or gasket is missing.	Tighten with a gasket in.	
	Air leakage between cylinder block and cylinder head.	Check cylinder gasket and the flatness of the surface where the cylinder block contacts the cylinder head.	
		Tighten cylinder head bolts in stipulated order to stipulated torque.	
Air leakage in the valves.	Check valve clearance and tightness. Repair if necessary.		

If engine still doesn't start, contact our Technical Support Team for service and/or repair.

⚠ WARNING

- When testing the spark plug, never hold the high-voltage wire of the spark plug with wet hand.
- Make sure there is no spilled fuel outside the engine and that the spark plug isn't covered with fuel.
- To prevent fire, keep sparks far away from the spark plug mounting hole.

Gasoline Engine: No Power

Problem	Cause	Solution
When increasing throttle, speed increase slow (or even decreases and stops running)/poor compression	Air in fuel line or fuel line clogged.	Exhaust air or dredge fuel line.
	Main oil flow hole is not adjusted properly.	Readjust.
	In carburetor, needle valve hole and main oil flow hole clogged.	Clean and blow to clear.
	Fuel cock is clogged up.	Clean/replace damaged part.
	Too much carbon deposit in combustion chamber.	Clear away.
	Too much carbon fouling in muffler and exhaust pipe.	Clear away.
	Air cleaner is clogged up.	Clean air cleaner filter element.
	Intake pipe is leaking.	Repair or replace.
	Piston or cylinder or piston ring is worn.	Replace the worn part.
	Air leakage from the surface where the cylinder block contacts the cylinder head.	Replace cylinder gasket.
	Too big or too small valve clearance.	Readjust.
	Valve tightness is poor.	Repair.

Gasoline Engine Running Roughly

Problem	Cause	Solution
Knocking sound	Piston, cylinder or piston ring is worn excessively.	Replace the worn part.
	Piston pin and piston pin hole are worn excessively.	Replace piston or piston pin.
	Piston pin and piston pin hole are worn excessively.	Replace tie rod.
	Roller bearing for crankshaft main shaft is worn.	Replace roller bearing.
Abnormal combustion	Engine is too hot.	Shut down and allow engine to cool off before troubleshooting.
	Too much carbon deposit in combustion chamber.	Clear away.
	Improper gasoline brand or low gasoline quality.	Replace with qualified gasoline.
Spark plug	There is water in float chamber.	Clean.
	Improper spark plug electrodes clearance.	Adjust.
	Faulty spark plug.	Replace spark plug.

Stops Suddenly When Running

Problem	Cause	Solution
Stops suddenly while running	Operated on a hill.	Keep engine oil level within targets and operate tiller on inclines less than 15 degrees, or disconnect oil sensor wire temporarily.
	Unit bounces or hops.	
	Pulling back swiftly on the handlebars.	
	Fuel is empty.	Refill fuel.
	Carburetor is clogged.	Check fuel line and dredge.
	Float is leaking.	Repair.
	Needle valve is stuck.	Dismantle float chamber and eliminate.
	Spark plug is punctured, or short-circuited by carbon deposit.	Replace spark plug.
	Side electrode of spark plug is dropped out.	Replace spark plug.
	Ignition coil is punctured or short-circuited.	Replace ignition coil.
	Cylinder is seriously scored and valve dropped out.	Repair or replace damaged parts.

Engine is Overheating

Problem	Cause	Solution
Engine is overheating	Oil level is low	Fill oil to proper level
	Exhaust pipe blocked up	Clean exhaust pipe
	Shroud leaking	Repair damaged part
	Cooling fins blocked by foreign matter	Clean cooling fins
	Cooling fan loosened and malfunctioning.	Reinstall properly
	Connection rod deformation has made piston and cylinder bushing side wear	Replace connection rod
	Cylinder or piston or piston ring is worn and made a space between cylinder and crankcase	Replace the worn parts
	Crankshaft main bearing burned out	Replace main bearing
Beating sound	Piston, piston ring or cylinder is worn	Replace the worn part
	Connection rod or piston pin and piston pin hole are worn	Replace the worn part
	Crankshaft main neck is worn	Replace the worn bearing
	Piston ring is broken	Replace piston ring
Metal beating sound when abnormal combustion occurs	Too much carbon deposit in combustion chamber	Clear away carbon deposit
	Insufficient electrode clearance of spark plug	Adjust electrode clearance properly
Other	Improper valve clearance	Readjust valve clearance properly
	Fly wheel is not connected with crankshaft tightly	Tighten

For further technical support:

Technical Support Team
 Mon-Fri 8:30 AM-5:00 PM (PST/PDT)
 Toll Free 1-877-338-0999
 support@championpowerequipment.com

WARRANTY*

CHAMPION POWER EQUIPMENT
2 YEAR LIMITED WARRANTY

Warranty Qualifications

To register your product for warranty and FREE lifetime call center technical support please visit:

<https://www.championpowerequipment.com/register>

To complete registration you will need to include a copy of the purchase receipt as proof of original purchase. Proof of purchase is required for warranty service. Please register within ten (10) days from date of purchase.

Repair/Replacement Warranty

CPE warrants to the original purchaser that the mechanical and electrical components will be free of defects in material and workmanship for a period of two years (parts and labor) from the original date of purchase. Transportation charges on product submitted for repair or replacement under this warranty are the sole responsibility of the purchaser. This warranty only applies to the original purchaser and is not transferable.

Do Not Return The Unit To The Place Of Purchase

Contact CPE's Technical Service and CPE will troubleshoot any issue via phone or e-mail. If the problem is not corrected by this method, CPE will, at its option, authorize evaluation, repair or replacement of the defective part or component at a CPE Service Center. CPE will provide you with a case number for warranty service. Please keep it for future reference. Repairs or replacements without prior authorization, or at an unauthorized repair facility, will not be covered by this warranty.

Warranty Exclusions

This warranty does not cover the following:

Normal Wear

Products with mechanical and electrical components need periodic parts and service to perform well. This warranty does not cover repair when normal use has exhausted the life of a part or the equipment as a whole.

Installation, Use and Maintenance

This warranty will not apply to parts and/or labor if the product is deemed to have been misused, neglected, involved in an accident, abused, loaded beyond the product's limits or modified. Normal maintenance is not covered by this warranty and is not required to be performed at a facility or by a person authorized by CPE.

Other Exclusions

This warranty excludes:

- Cosmetic defects such as paint, decals, etc.
- Wear items such as filter elements, o-rings, etc.
- Failures due to acts of God and other force majeure events beyond the manufacturer's control.
- Problems caused by parts that are not original Champion Power Equipment parts.

Limits of Implied Warranty and Consequential Damage

Champion Power Equipment disclaims any obligation to cover any loss of time, use of this product, freight, or any incidental or consequential claim by anyone from using this product. THIS WARRANTY AND THE ATTACHED U.S. EPA and/or CARB EMISSION CONTROL SYSTEM WARRANTIES (WHEN APPLICABLE) ARE IN LIEU OF ALL OTHER WARRANTIES, EXPRESS OR IMPLIED, INCLUDING WARRANTIES OF MERCHANTABILITY OR FITNESS FOR A PARTICULAR PURPOSE.

A unit provided as an exchange will be subject to the warranty of the original unit. The length of the warranty governing the exchanged unit will remain calculated by reference to the purchase date of the original unit.

This warranty gives you certain legal rights which may change from state to state or province to province. Your state or province may also have other rights you may be entitled to that are not listed within this warranty.

Contact Information

Address

Champion Power Equipment, Inc.
12039 Smith Ave.
Santa Fe Springs, CA 90670 USA
www.championpowerequipment.com

Customer Service

Mon – Fri 8:30 AM – 5:00 PM (PST/PDT)
Toll Free: 1-877-338-0999
info@championpowerequipment.com
Fax no.: 1-562-236-9429

Technical Service

Mon – Fri 8:30 AM – 5:00 PM (PST/PDT)
Toll Free: 1-877-338-0999
tech@championpowerequipment.com
24/7 Tech Support: 1-562-204-1188

*Except as otherwise stipulated in any of the following enclosed Emission Control System Warranties (when applicable) for the Emission Control System: U.S. Environment Protection Agency (EPA) and/or California Air Resources Board (CARB).

**CHAMPION POWER EQUIPMENT, INC. (CPE),
THE UNITED STATES ENVIRONMENT PROTECTION AGENCY (U.S. EPA)
AND THE CALIFORNIA AIR RESOURCES BOARD (CARB) EMISSION CONTROL SYSTEM WARRANTY**

Your Champion Power Equipment (CPE) engine complies with both the U.S. EPA and state of California Air Resources Board (CARB) Exhaust and Evaporative emissions regulations.

YOUR WARRANTY RIGHTS AND OBLIGATIONS:

The US EPA, California Air Resources Board, and CPE are pleased to explain the Federal and California Exhaust and Evaporative Emission Control Systems Warranty on your 2019 small off-road engine (SORE) and engine powered equipment. In California, new equipment that use small off-road engines (SORE) must be designed, built and equipped to meet the State's stringent anti smog standards. In the other states, new engines and equipment must be designed, built and equipped, at the time of sale, to meet U.S. EPA regulations for small off-road engines (SORE). CPE must warrant the exhaust and evaporative emission control system on your small off-road engine (SORE) for the period listed below, provided there has been no abuse, neglect, unapproved modification, or improper maintenance of your equipment leading to the failure of the exhaust and evaporative emission control systems.

Your evaporative emission control system may include parts such as: carburetors, fuel tanks, fuel lines, (for liquid fuel and fuel vapors), fuel caps, valves, canisters, filters, clamps, connectors, and other associated components. Also included for your exhaust emission control system may be fuel-injection system, the ignition system, catalytic converter and other exhaust emission related assemblies. Where a warrantable condition exists, CPE will repair your small off-road engine (SORE) at no cost to you including diagnosis, parts and labor.

MANUFACTURER'S WARRANTY COVERAGE:

This exhaust and evaporative emission control system is warranted for two years. If any exhaust and evaporative, emission related part on your engine or equipment is defective in, the part will be repaired or replaced by CPE.

OWNER WARRANTY RESPONSIBILITIES:

As the small off-road engine (SORE) owner, you are responsible for the performance of the required maintenance listed in your Owner's Manual. CPE recommends that you retain all your receipts covering maintenance on your small off-road engine (SORE), but CPE cannot deny warranty coverage solely for the lack of receipts.

As the small off-road engine (SORE) owner, you should be aware that CPE may deny you warranty coverage if your small, off-road engine (SORE) or a part has failed due to abuse, neglect, improper maintenance or unapproved modifications.

You are responsible for presenting your small off-road engine to an Authorized CPE distribution center, service center or alternative service outlet as described in (3)(f.) below or CPE dealer or CPE, Santa Fe Springs, Ca. as soon as the problem exists. The warranty repairs shall be completed in a reasonable amount of time, not to exceed 30 days.

If you have any questions regarding your warranty coverage, you should contact:

Champion Power Equipment, Inc.
Customer Service
12039 Smith Ave.
Santa Fe Springs, CA 90670
1-877-338-0999
tech@championpowerequipment.com

EXHAUST AND EVAPORATIVE EMISSION CONTROL SYSTEM WARRANTY

The following are specific provisions relative to your Exhaust and Evaporative Emission Control System (ECS) Warranty Coverage.

- 1. APPLICABILITY:** This warranty shall apply to 1995 and later model year California small off-road engines (SORE) (for other states, 1997 and later model year engines). The ECS Warranty Period shall begin on the date the new engine or equipment is delivered to its original, end-use purchaser, and shall continue for 24 consecutive months thereafter.
- 2. GENERAL EMISSIONS WARRANTY COVERAGE**

CPE warrants to the original, end-use purchaser of the new engine or equipment and to each subsequent purchaser that each of its small off-road engines (SORE) is:

 - 2a. Designed, built and equipped to conform to U.S. EPA emissions standards for spark-ignited engines at or below 19 kilowatts and all applicable regulations adopted by the California Air Resources Board, and
 - 2b. Free from defects in materials and workmanship that cause the failure of a warranted part to be identical in all material respects to the part as described in the engine manufacturer's application for certification for a period of two years.
- 3. THE WARRANTY ON EXHAUST AND EVAPORATIVE EMISSION-RELATED PARTS WILL BE INTERPRETED AS FOLLOWS:**
 - 3a. Any warranted part that is not scheduled for replacement as required maintenance in the Owners Manual shall be warranted for the ECS Warranty Period. If any such part fails during the ECS Warranty Period, it shall be repaired or replaced by CPE according to Subsection "d" below. Any such part repaired or replaced under the ECS Warranty shall be warranted for any remainder of the ECS Warranty Period.
 - 3b. Any warranted, exhaust and evaporative emissions-related part which is scheduled only for regular inspection as specified in the Owners Manual shall be warranted for the ECS Warranty Period. A statement in such written instructions to the effect of "repair or replace as necessary", shall not reduce the ECS Warranty Period. Any such part repaired or replaced under the ECS Warranty shall be warranted for the remainder of the ECS Warranty Period.
 - 3c. Any warranted, exhaust and evaporative emissions-related part which is scheduled for replacement as required maintenance in the Owner's Manual shall be warranted for the period of time prior to the first scheduled replacement point for that part. If the part fails prior to the first scheduled replacement, the part shall be repaired or replaced by CPE according to Subsection "d" below. Any such exhaust and evaporative emissions-related part repaired or replaced under the ECS Warranty, shall be warranted for the remainder of the ECS Warranty Period prior to the first scheduled replacement point for such emissions-related part.
 - 3d. Repair or replacement of any warranted, exhaust and evaporative emissions-related part under this ECS Warranty shall be performed at no charge to the owner at a CPE Authorized Service Outlet.
 - 3e. The owner shall not be charged for diagnostic labor which leads to the determination that a part covered by the ECS Warranty is in fact defective, provided that such diagnostic work is performed at a CPE Authorized Service Outlet.
 - 3f. CPE shall pay for covered exhaust and evaporative emissions warranty repairs at non-authorized service outlets under the following circumstances:
 - i. The service is required in a population center with a population over 100,000 according to U.S. Census 2000 without a CPE Authorized Service Outlet AND
 - ii. The service is required more than 100 miles from a CPE Authorized Service Outlet. The 100 mile limitation does not apply in the following states: Alaska, Arizona, Colorado, Hawaii, Idaho, Montana, Nebraska, Nevada, New Mexico, Oregon, Texas, Utah and Wyoming.
 - 3g. CPE shall be liable for damages to other original engine components or approved modifications proximately caused by a failure under warranty of an emission-related part covered by the ECS Warranty.
 - 3h. Throughout the ECS Warranty Period, CPE shall maintain a supply of warranted exhaust and evaporative emission-related parts sufficient to meet the expected demand for such exhaust and evaporative emission-related parts.
 - 3i. Any CPE Authorized and approved exhaust and evaporative emission-related replacement part may be used in the performance of any ECS Warranty maintenance or repair and will be provided without charge to the owner. Such use shall not reduce CPE's warranty obligation.
 - 3j. Unapproved add-on or modified parts may not be used to modify or repair a CPE engine. Such use voids this ECS Warranty and shall be sufficient grounds for disallowing an ECS Warranty claim. CPE shall not be liable hereunder for failures of any warranted parts of a CPE engine caused by the use of such an unapproved add-on or modified part.

EMISSION-RELATED PARTS INCLUDE THE FOLLOWING: (using those portions of the list applicable to the engine)

Systems covered by this warranty	Parts Description
Fuel Metering System	Fuel regulator, Carburetor and internal parts
Air Induction System	Air cleaner, Intake manifold
Ignition System	Spark plug and parts, Magneto ignition system
Exhaust System	Exhaust manifold, catalytic converter
Miscellaneous Parts	Tubing, Fittings, Seals, Gaskets, and Clamps associated with these listed systems.
Evaporative Emissions	Fuel Tank, Fuel Cap, Fuel Lines (for liquid fuel and fuel vapors), Fuel Line Fittings, Clamps, Pressure Relief Valves, Control Valves, Control Solenoids, Electronic Controls, Vacuum Control Diaphragms, Control Cables, Control Linkages, Purge Valves, Gaskets, Liquid/Vapor Separator, Carbon Canister, Canister Mounting Brackets, Carburetor Purge Port Connector

TO OBTAIN WARRANTY SERVICE:

You must take your CPE engine or the product on which it is installed, along with your warranty registration card or other proof of original purchase date, at your expense, to any Champion Power Equipment dealer who is authorized by Champion Power Equipment, Inc. to sell and service that CPE product during his normal business hours. Alternate service locations defined in Section (3)(f.) above must be approved by CPE prior to service. Claims for repair or adjustment found to be caused solely by defects in material or workmanship will not be denied because the engine was not properly maintained and used.

If you have any questions regarding your warranty rights and responsibilities, or to obtain warranty service, please write or call Customer Service at Champion Power Equipment, Inc.

Champion Power Equipment, Inc.
12039 Smith Ave.
Santa Fe Springs, CA 90670
1-877-338-0999
Attn.: Customer Service
tech@championpowerequipment.com