

CHAMPION

POWER EQUIPMENT

TM-MC

OWNER'S MANUAL



2 INCH CHEMICAL WATER TRANSFER PUMP



MODEL NUMBER

66526

SAVE THESE INSTRUCTIONS
Important safety instructions
are included in this manual.

MADE IN CHINA
REV 66526-20180530

12039 Smith Ave.
Santa Fe Springs CA 90670
USA / 1-877-338-0999
www.championpowerequipment.com

AN IMPORTANT MESSAGE ABOUT TEMPERATURE:

Your Champion Power Equipment product is designed and rated for continuous operation at ambient temperatures up to 40°C (104°F). When your product is needed your product may be operated at temperatures ranging from -15°C (5°F) to 50°C (122°F) for short periods. If the product is exposed to temperatures outside this range during storage, it should be brought back within this range before operation. In any event, the product must always be operated outdoors, in a well-ventilated area and away from doors, windows and other vents.

Have questions or need assistance?

Do not return this product to the store!

WE ARE HERE TO HELP!

Visit our website:

www.championpowerequipment.com

for more info:

- Product Info & Updates
- Tech Bulletins
- Frequently Asked Questions
- Product Registration

– or –

Call our Customer Care Team Toll-Free at:

1-877-338-0999

Parts Ordering:

Mon – Fri 8:30 AM – 5:00 PM (PST/PDT)

Toll Free: 1-877-338-0999

For residents of California:

WARNING: This product contains chemicals known to the State of California to cause cancer or birth defects and other reproductive harm.

WARNING: The engine exhaust from this product contains chemicals known to the State of California to cause cancer and birth defects and other reproductive harm.

*We are always working to improve our products. Therefore, the enclosed product may differ slightly from the image on the cover.

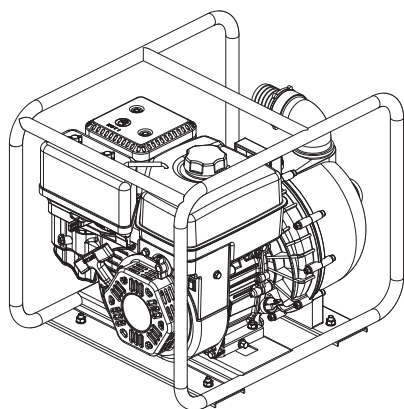

2 INCH CHEMICAL WATER TRANSFER PUMP

TABLE OF CONTENTS

Introduction	1	Specifications	15
Manual Conventions	2	Engine Specifications	15
Safety Rules	3	Chemical Pump Specifications	15
Controls and Features	5	Fuel	15
Chemical Pump	5	Oil	15
Parts Included	6	Spark Plugs	15
Other	6	Maintenance Valve Clearance	15
Assembly	7	An Important Message About Temperature	15
Remove the Chemical Pump from the Shipping Carton	7	Troubleshooting	16
Add Engine Oil	7	Parts Diagram	17
Add Fuel	7	Parts List	18
Connecting Hose or Pipes	8	Engine Parts Diagram	19
Clear water use	8	Engine Parts List	20
Operation	9		
Chemical Pump Location	9		
Pumping	9		
Liquids Only	9		
Chemicals	9		
Pesticides	10		
Priming the Pump	10		
Starting the Engine	10		
Stopping the Engine	11		
Operation at High Altitude	11		
Maintenance and Storage	12		
Engine Maintenance	12		
Oil	12		
Spark Plugs	12		
Air Filter	12		
Cleaning	13		
Adjustments	13		
Maintenance Schedule	13		
Flushing the Pump	13		
Drain Plug	13		
Storage	13		
Engine Storage	13		
Chemical Pump Storage	13		
Winter Storage	14		

INTRODUCTION

Congratulations on your purchase of a Champion Power Equipment product. Champion Power Equipment and Champion Engine Technology designs, builds, and supports all of our products to strict specifications and guidelines. With proper product knowledge, safe use, and regular maintenance, this product should bring years of satisfying service.

Every effort has been made to ensure the accuracy and completeness of the information in this manual, and we reserve the right to change, alter and/or improve the product and this document at any time without prior notice.

Since CPE/CET highly value how our products are designed, manufactured, operated and are serviced, and also highly value your safety and the safety of others, we would like you to take the time to review this product manual and other product materials thoroughly and be fully aware and knowledgeable of the assembly, operation, dangers and maintenance of the product before use. Fully familiarize yourself, and make sure others who plan on operating the product fully familiarize themselves too, with the proper safety and operation procedures before each use. Please always exercise common sense and always err on the side of caution when operating the product to ensure no accidents, property damage, or injury occurs. We want you to continue to use and be satisfied with your CPE/CET product for years to come.

Record the model and serial numbers as well as date and place of purchase for future reference. Have this information available when ordering parts and when making technical or warranty inquiries.

Champion Power Equipment Support	
1-877-338-0999	
Model Number	
66526	
Serial Number	
Date of Purchase	
Purchase Location	
For Oil Type see 'Add Engine Oil' section. For Fuel Type see 'Add Fuel' section.	

This manual uses the following symbols to help differentiate between different kinds of information. The safety symbol is used with a key word to alert you to potential hazards in operating and owning power equipment.

Follow all safety messages to avoid or reduce the risk of serious injury or death.

 **DANGER**

DANGER indicates an imminently hazardous situation which, if not avoided, **will** result in death or serious injury.

 **WARNING**

WARNING indicates a potentially hazardous situation which, if not avoided, **could** result in death or serious injury.

 **CAUTION**

CAUTION indicates a potentially hazardous situation which, if not avoided, **may** result in minor or moderate injury.

CAUTION

CAUTION used without the safety alert symbol indicates a potentially hazardous situation which, if not avoided, **may** result in property damage.

 **NOTE**

If you have questions regarding your chemical pump, we can help. Please call our help line at **1-877-338-0999**

SAFETY RULES

WARNING

Read this manual thoroughly before operating your chemical pump. Failure to follow instructions could result in serious injury or death.

DANGER

DO NOT pump gasoline and fuel oil mixtures, detergents, acids, beverages, fertilizers or any other flammable liquid or corrosive.

Pumping volatile liquids may result in an explosion or fire. These liquids will corrode the pump and void your warranty.

WARNING

The engine exhaust from this product contains chemicals known to the state of California to cause cancer, birth defects, or other reproductive harm.

DANGER

Engine exhaust contains carbon monoxide, a colorless, odorless, poison gas. Breathing carbon monoxide will cause nausea, dizziness, fainting or death. If you start to feel dizzy or weak, get to fresh air immediately.

Operate chemical pump outdoors only in a well ventilated area DO NOT operate the chemical pump inside any building, enclosure or compartment. DO NOT allow exhaust fumes to enter a confined area through windows, doors, vents or other openings.

DANGER

Do not eat, drink, smoke, or touch your eyes, face or any part of your skin while pumping any materials, chemicals or pesticides. It is recommended that gloves, safety glasses and other proper safety gear be worn at all times when handling any and all materials, chemicals, pesticides or, prepping, pumping and flushing chemicals. Always follow the proper warnings and instructions when handling, prepping, pumping, and flushing any and all materials, chemicals and pesticides.

WARNING

Clean up any spills of chemicals, pesticides, and any potentially hazardous materials IMMEDIATELY. Chemicals, pesticides and any potentially hazardous materials can contaminate if not properly cleaned up quickly.

DANGER

Rotating parts can entangle hands, feet, hair, clothing and/or accessories. Traumatic amputation or severe laceration can result.

Keep hands and feet away from rotating parts. Tie up long hair and remove jewelry. Operate equipment with guards in place. DO NOT wear loose-fitting clothing, dangling drawstrings or items that could become caught.

DANGER

The chemical pump develops powerful force.

DO NOT move the chemical pump when it is in use. DO NOT use hoses or connectors that are worn, damaged or frayed. DO NOT allow children or unqualified persons to operate or service the chemical pump. DO NOT open top plug or drain plug when in use.

WARNING

Sparks can result in fire or electrical shock.

When servicing the chemical pump:

Disconnect the spark plug wire and place it where it cannot contact the plug. DO NOT check for spark with the plug removed. Use only approved spark plug testers.

WARNING

DO NOT immerse this unit in water.

WARNING

Do not pump any materials (chemical, hazardous, or otherwise) in the direction of any water supply. This may cause contamination and/or unsafe water conditions.

WARNING

Do not pump any materials (chemical, hazardous, or otherwise) in the direction of any person, animal, or plant life, as this may cause serious damage, injury or death.

WARNING

All local and federal laws must be followed at all times when handling, prepping, pumping and flushing any and all chemicals, pesticides, and any potentially hazardous materials.

⚠ DANGER

Fuel and fuel vapors are highly flammable and extremely explosive.
Fire or explosion can cause severe burns or death.
Unintentional startup can result in entanglement, traumatic amputation or laceration.

When adding or removing fuel:

Turn the engine off and let it cool for at least two minutes before removing the fuel cap. Loosen the cap slowly to relieve pressure in the tank.
Only fill or drain fuel outdoors in a well-ventilated area.
DO NOT pump gas directly into the engine at the gas station. Use an approved container to transfer the fuel to the engine.
DO NOT overfill the fuel tank.
Always keep fuel away from sparks, open flames, pilot lights, heat and other sources of ignition.
DO NOT light or smoke cigarettes.

When starting the engine:

DO NOT attempt to start a damaged engine. Make certain that the gas cap, air filter, spark plug, fuel lines and exhaust system are properly in place. Allow spilled fuel to evaporate fully before attempting to start the engine.
Make certain that the chemical pump is resting firmly on level ground.

When operating the chemical pump:

DO NOT move or tip the chemical pump during operation.
DO NOT tip the chemical pump or allow fuel or oil to spill from the engine. Block the wheels to prevent unintended movement.

When transporting or servicing the chemical pump:

Make certain that the fuel shutoff valve is in the off position and the fuel tank is empty.

Disconnect the spark plug wire.

When storing the chemical pump:

Store away from sparks, open flames, pilot lights, heat and other sources of ignition.

⚠ WARNING

Water pumped through this unit shall not be used as drinking water.

⚠ WARNING

DO NOT remove either prime (top), or drain (bottom) plugs while the chemical pump is on and running

Loss of pressure and suction will occur. Property damage and injury may also occur.

⚠ WARNING

DO NOT pump salt, sludge, sewer, sea, or any other type of water containing solid material.

⚠ WARNING

Rapid retraction of the starter cord will pull hand and arm towards the engine faster than you can let go.
Unintentional startup can result in entanglement, traumatic amputation or laceration.
Broken bones, fractures, bruises or sprains could result.

When starting engine, pull the starter cord slowly until resistance is felt and then pull rapidly to avoid kickback.

⚠ CAUTION

Exceeding the chemical pump's specification for maximum head can damage the chemical pump and/or hose kits connected to it.

DO NOT modify the chemical pump in any way. DO NOT attempt to exceed the rated flow. Attempting to increase the rated flow may damage the unit and/or shorten its life.

⚠ CAUTION

Improper treatment or use of the chemical pump can damage it, shorten its life and void your warranty.

Use the chemical pump only for intended uses. Operate only on level surfaces. DO NOT expose chemical pump to excessive moisture, dust, or dirt.
DO NOT allow any material to block the cooling slots.
DO NOT use the chemical pump if:

- Equipment sparks, smokes or emits flames
- Equipment vibrates excessively

CAUTION

The pump is not meant to pull through, pass, or pump any solids. Please make sure material that is pumped is liquid only. Solids, debris and trash may cause damage to the pump.

CAUTION

Lay sturdy planking along each side of the hose or pipe, when the hose or pipe runs across any type of roadway. Make sure that the planking length will run the length of the roadway. This will ensure some protection of the hose or pipe from any passing vehicles.

CONTROLS AND FEATURES

Read this owner's manual before operating your chemical pump. Familiarize yourself with the location and function of the controls and features. Save this manual for future reference.

Chemical Pump

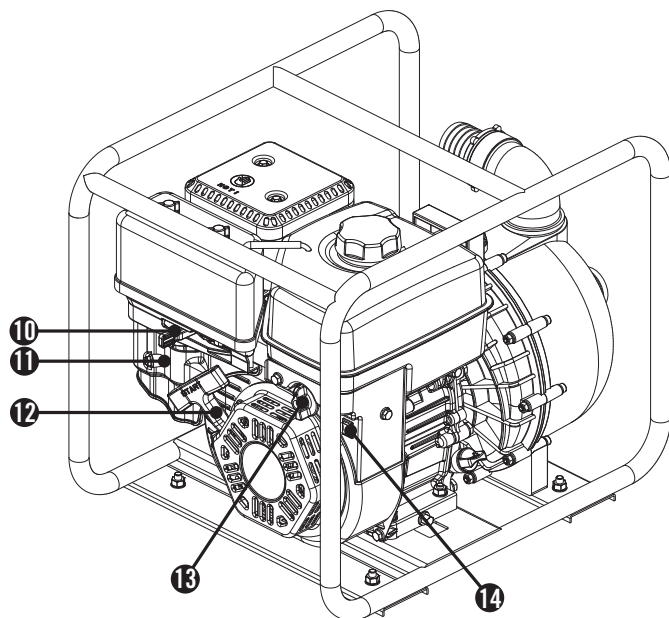
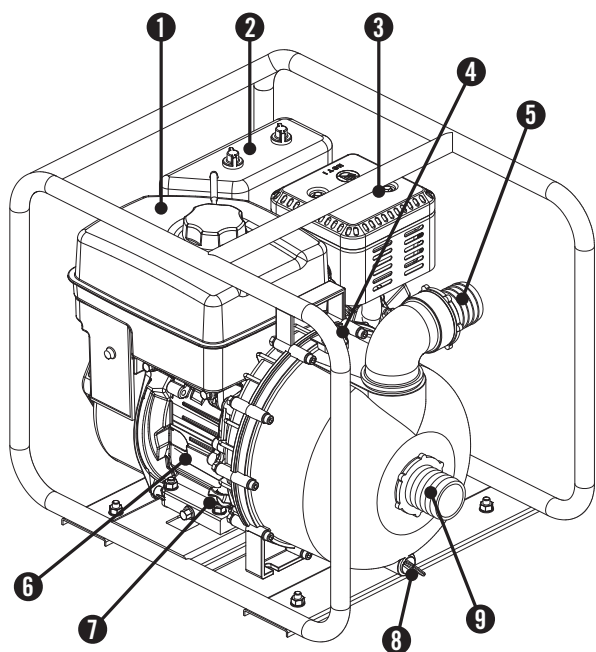

- (1) **Fuel Tank** – 0.9 gal. (3.4 L) capacity fuel tank.
- (2) **Air Filter** – Protects the engine by filtering dust and debris from the air intake.
- (3) **Muffler**
- (4) **Prime Plug** – Used to prime the pump.
- (5) **2 in. (5.1 cm) Outlet** – 2 in. (5.1 cm) NPT outlet connector.
- (6) **Low Oil Sensor** – Senses the level of oil in the crankcase and shuts the engine down if the level falls too low.
- (7) **Oil Filler Cap** – Check and fill engine oil level.

- (8) **Drain Plug**
- (9) **2 in. (5.1 cm) Inlet** – 2 in. (5.1 cm) NPT inlet connector.
- (10) **Throttle Lever** – Used to adjust engine speed.
- (11) **Choke lever** – Used to start the engine.
- (12) **Recoil Starter** – Used to start the engine.
- (13) **Fuel Valve** – Used to turn fuel supply on and off to engine.
- (14) **Engine Switch** – Used to start the engine.

Parts Included

Your model 66526 gasoline powered chemical pump ships with the following parts:

Other

- Oil Funnel 1
- 2 in. 90 Degree Fitting 1
- 2 in. Straight Fitting 2
- Seal 3

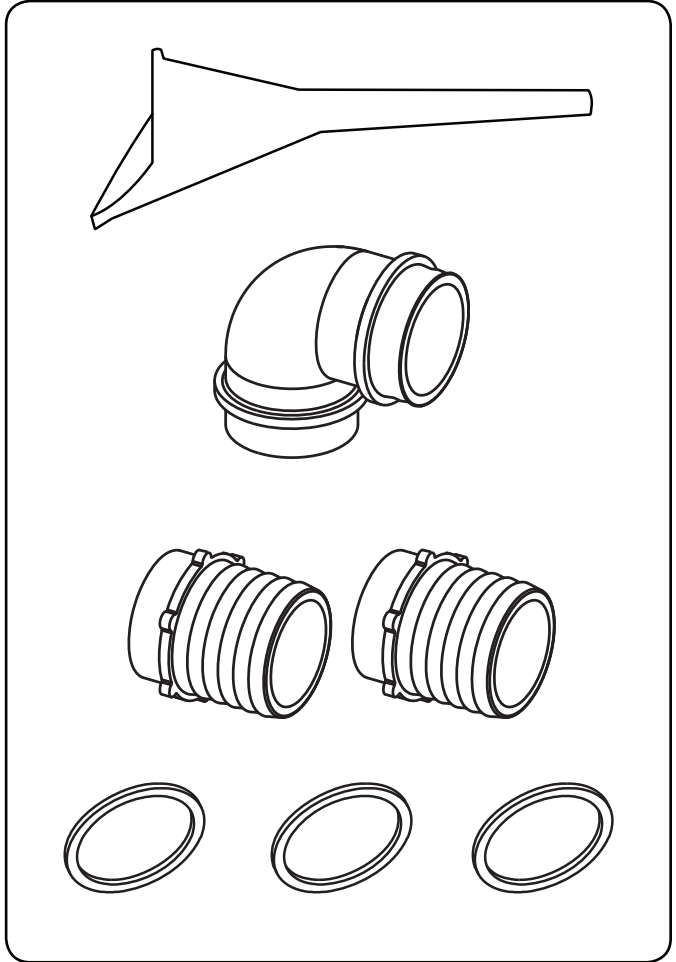

ASSEMBLY

Your chemical pump requires some assembly. This unit ships from our factory without oil. It must be properly serviced with fuel and oil before operation.

If you have any questions regarding the assembly of your chemical pump, call our help line at 1-877-338-0999. Please have your serial number and model number available.

Remove the Chemical Pump from the Shipping Carton

1. Set the shipping carton on a solid, flat surface.
2. Remove everything from the carton except the chemical pump.
3. Carefully cut each corner of the box from top to bottom.

Add Engine Oil

! CAUTION

DO NOT attempt to crank or start the engine before it has been properly filled with the recommended type and amount of oil. Damage to the chemical pump as a result of failure to follow these instructions will void your warranty.

NOTE

The recommended oil type is 10W-30 automotive oil.

1. Place the chemical pump on a flat, level surface.
2. Remove oil fill cap/dipstick to add oil.
3. Using a funnel add up to 0.6 qt. (0.6 L) of oil (not included) and replace oil fill cap/dipstick.
4. It is recommended to only fill to the base of the oil fill hole. DO NOT OVERFILL.
5. Check engine oil level daily and add as needed.

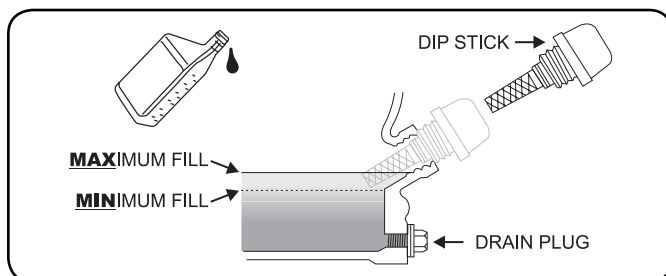

NOTE

Once oil has been added, a visual check should show oil about 1-2 threads from running out of the fill hole. If using the dipstick to check oil level, DO NOT screw in the dipstick while checking.

Add Engine Oil Cont'd.

NOTE

Check oil often during the break-in period. Refer to the Maintenance section for recommended service intervals.

CAUTION

The engine is equipped with a low oil shut-off and will stop when the oil level in the crankcase falls below the threshold level.

NOTE

Weather will affect engine oil and engine performance. Change the type of engine oil used based on weather conditions to suit the engine needs.

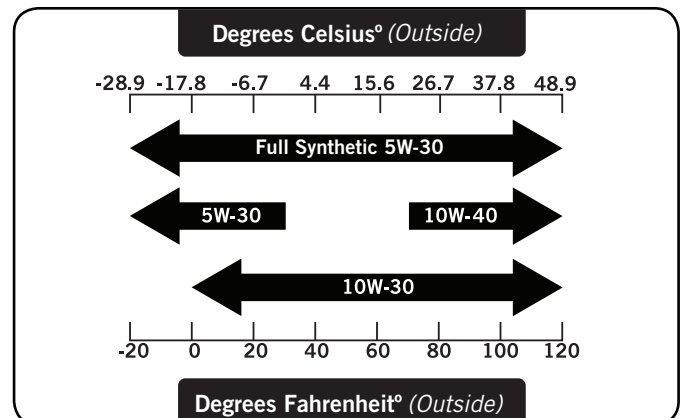

NOTE

We consider the first 5 hours of run time to be the break-in period for the engine. During the break in period we recommend using standard automotive non-synthetic blended oils. After the break in period synthetic lubricant can be used but is not required. Adjusting throttle setting will increase/decrease engine speed helping to seat piston rings. Avoid bogging or lugging the engine down and avoid prolonged running at constant RPM. After the 5 hour break-in period, change the oil. Using synthetic lubricants does not increase the recommended oil change interval.

NOTE

Synthetic oil may be used after the 5 hour initial break-in period. Using synthetic oil does not increase the recommended oil change interval.

Add Fuel

1. Use clean, fresh, regular unleaded fuel with a minimum octane rating of 85 and an ethanol content of less than 10% by volume.
2. DO NOT mix oil with fuel.
3. Clean the area around the fuel cap.
4. Remove the fuel cap.
5. Slowly add fuel to the tank. DO NOT OVERFILL. Fuel can expand after filling. A minimum of ¼ in. (6.4 mm) of space left in the tank is required for fuel expansion, more than ¼ in. (6.4 mm) is recommended. Fuel can be forced out of the tank as a result of expansion if it is overfilled, and can affect the stable running condition of the product. When filling the tank, it is recommended to leave enough space for the fuel to expand.
6. Screw on the fuel cap and wipe away any spilled fuel.

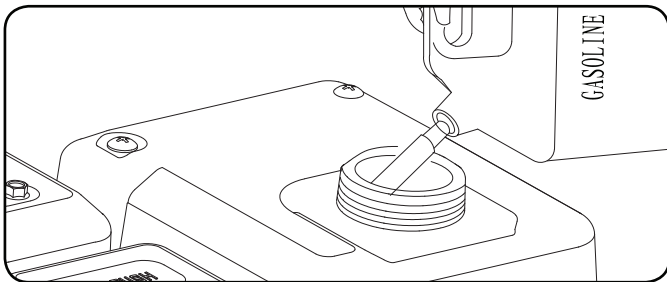

⚠ WARNING

Pouring fuel too fast through the fuel screen may result in blow back of fuel at the operator while filling.

⚠ CAUTION

Use regular unleaded gasoline with a minimum octane rating of 85.

Do not mix oil and gasoline.
 Fill tank to approximately ¼ in. (6.4 mm) below the top of the tank to allow for fuel expansion.
 DO NOT pump gas directly into the chemical pump at the gas station. Use an approved container to transfer the fuel to the chemical pump.
 DO NOT fill fuel tank indoors.
 DO NOT fill fuel tank when the engine is running or hot.
 DO NOT overfill the fuel tank.
 DO NOT light cigarettes or smoke when filling the fuel tank.

Add Fuel Cont'd.

NOTE

Our engines work well with 10% or less ethanol blend fuels. When using blended fuels there are some issues worth noting:

- Ethanol-gasoline blends can absorb more water than gasoline alone.
- These blends can eventually separate, leaving water or a watery goo in the tank, fuel valve and carburetor.
- With gravity-fed fuel supplies, this compromised fuel can be drawn into the carburetor and cause damage to the engine and/or potential hazards.
- There are only a few suppliers of fuel stabilizer that are formulated to work with ethanol blend fuels.
- Any damages or hazards caused by using improper fuel, improperly stored fuel, and/or improperly formulated stabilizers, are not covered by manufacturer's warranty.

It is advisable to always shut off the fuel supply, run the engine to fuel starvation and drain the tank when the equipment is not in use for more than 30 days.

Connecting Hose or Pipes

Hoses or pipes can be connected to the pump using 2 in. (5.1 cm) NPT pipe fittings.

Teflon tape is required to ensure a liquid tight seal.

Do not connect rigid pipe directly to the pump as this can cause excess stress that can damage the pump.

Always use at least 12 in. (30.5 cm) of flexible hose between the pump and any rigid piping.

Clear Water Use

Apply thread tape to the outlet elbow (1) and then install it securely to the pump housing.

Apply thread tape to the two threaded barbed fittings (2) and securely install one in the suction port and the other in the outlet elbow.

⚠ WARNING

Do not use as clear water pump if previously used to move chemicals.

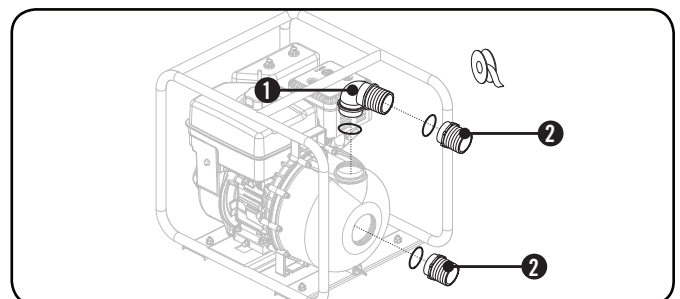

OPERATION

Chemical Pump Location

Place the chemical pump in a well ventilated area. DO NOT place the chemical pump near vents or intakes where exhaust fumes could be drawn into occupied or confined spaces. Carefully consider wind and air currents when positioning chemical pump.

This chemical pump must have at least 5 ft. (1.5 m) of clearance from combustible material. Leave at least 3 ft. (91.4 cm) of clearance on all sides of the chemical pump to allow for adequate cooling, maintenance and servicing.

Place the pump on a level surface free from any obstructions or potential hazards. The pump should be placed close to the water or chemical level to ensure maximum pump performance.

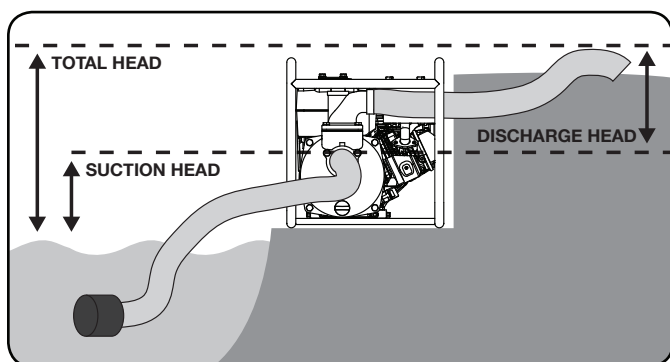

Pump output will be affected by the type, length, and size of the suction and discharge hoses. The pumping height, also known as the total head, is the distance from the water level to the point of discharge. As this distance increases, pump output decreases. The discharge capacity is greater than the suction capacity. Therefore, it is important that the suction head is less than the discharge head.

The time required to draw water or chemicals from the source to the pump (self-priming time) can be decreased by minimizing the suction head.

WARNING

DO NOT run the pump dry.

Running the pump dry can destroy the pump seals and will void the warranty. If the pump was running while dry, stop the engine and allow it to cool thoroughly before filling the chamber with water.

Pumping

WARNING

ONLY liquid materials, chemicals and pesticides are for use with this pump. Dry, solid or aerosolized materials, chemicals and pesticides are not to be used with this pump. Fumigants of any kind are not to be used with this pump.

WARNING

Once certain materials, chemicals or pesticides are used with the pump it is recommended that the pump is not used to water plants, trees, crops, live stock, or any other living creatures as certain material, chemicals and pesticides residue may remain in pump and be pumped through with any water or other liquid. This may cause serious harm to or even kill any plant life, crops, livestock or other living creatures.

NOTE

Flush the pump after every use. Flushing the pump, pipes and hose kits with water will only help to reduce the residue build up of materials, chemicals, and pesticide used and may not flush out the pump, pipes and hose kits completely.

Liquids Only - This pump may be used to transfer and pump a variety of chemicals and certain other substances including water, but they all must be liquid form only. This pump is not meant to have any solids, debris or trash, pass through or pumped through it. This will damage the pump. Please only pump liquid materials. A strainer or filter is always recommended for use when pumping, as this may help catch any solids that may otherwise pass through and damage the pump.

Chemicals - This pump may be used to pump certain chemicals, but must follow any warnings, cautions and directions for that specific chemical(s). Certain chemical can be and are hazardous. They must be handled with care and caution at all times. Follow all local and federal laws for any and all chemicals. DO NOT mix chemicals. Flushing the pump with water after using chemicals is recommended.

Pumping Cont'd.

Pesticides - This pump may be used to pump certain pesticides, but must follow any warnings, cautions and directions for that specific pesticide(s). Pesticides are hazardous chemicals that must be handled with care and caution at all times. Pesticides are regulated by the United States Environmental Protection Agency (EPA) and should follow any and all EPA guidelines for proper and safe use. It is recommended that both the specific pesticide guidelines and the United States EPA guidelines be followed at all times.

Pesticides may leave residue in the pump and any pipes or hose kits attached to the pump, so after each pesticide use, flushing the pump with water is recommended. If this pump is used to pump/spray any other non-flammable liquids and/or chemicals please keep in mind, residue from pesticides may also be pumped too.

Priming the Pump

1. Remove the Pump Priming Plug (#22)
2. Completely fill the pump with the liquid to be pumped.
3. Replace the Pump Priming Plug

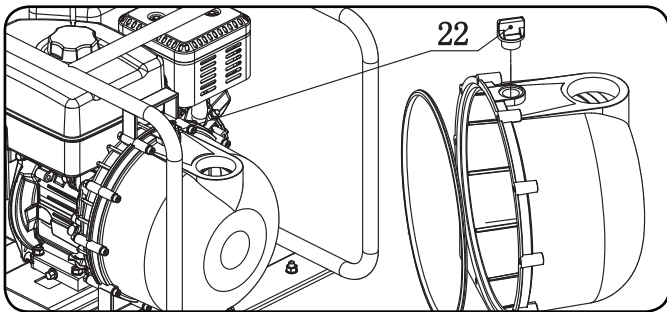

Starting the Engine

1. Make certain the chemical pump is on a flat, level surface.
2. Flip engine switch (A) to "ON" position.
3. Rotate the fuel valve (B) to the "ON" position.
4. Move the choke lever (C) to the "Choke" position.
5. Move throttle lever to middle position. (D)
6. Pull the starter cord slowly until resistance is felt and then pull rapidly.
7. As engine warms up, move the choke lever (C) to "Run".
8. Move the throttle lever (D) to the "Fast" position.

Starting the Engine Cont'd.

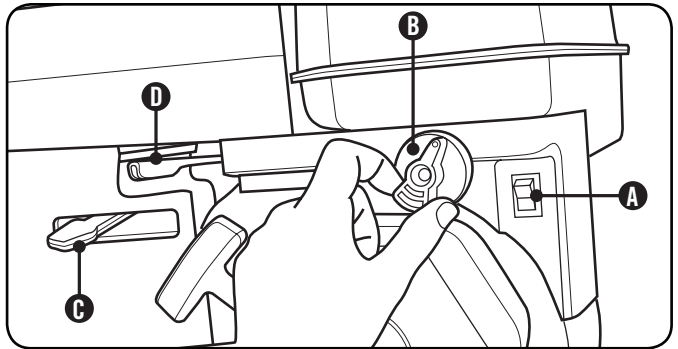

NOTE

If the engine starts but does not run make certain that the chemical pump is on a flat, level surface. The engine is equipped with a low oil sensor that will prevent the engine from running when the oil level falls below a critical threshold.

NOTE

Keep choke lever in "Choke" position for 2 pulls of the recoil starter. After 2 pulls, move choke lever to the "Run" position for up to the next 3 pulls of the recoil starter. Too much choke leads to spark plug fouling/engine flooding due to the lack of incoming air. This will cause the engine not to start.

NOTE

Pump performance can be adjusted using the throttle. To decrease pump output, slide the throttle to the right. To increase it, slide the throttle to the left.

WARNING

DO NOT remove either top, or drain (bottom) plugs while the chemical pump is on and running

Loss of pressure and suction will occur. Injury may also occur.

OPERATION

Stopping the Engine

1. Turn the fuel valve to the "OFF" position.
2. Let the engine run until fuel starvation has stopped the engine. This usually takes a few minutes.
3. Move the throttle lever to slow position.
4. Press the engine switch to the "OFF" position.

Important: Always ensure that the Fuel Valve and the Engine Switch are in the "OFF" position when the engine is not in use.

NOTE

If the engine will not be used for a period of two (2) weeks or longer, please see the Storage section for proper engine and fuel storage.

Operation at High Altitude

The density of air at high altitude is lower than at sea level. Engine power is reduced as the air mass and air-fuel ratio decrease. Engine power and generator output will be reduced approximately 3½% for every 1000 feet of elevation above sea level. This is a natural trend and cannot be changed by adjusting the engine. At high altitudes increased exhaust emissions can also result due to the increased enrichment of the air fuel ratio. Other high altitude issues can include hard starting, increased fuel consumption and spark plug fouling. To alleviate high altitude issues other than the natural power loss, Champion Power Equipment can provide a high altitude carburetor main jet. The alternative main jet and installation instructions can be obtained by contacting Customer Support. Installation instructions are also available in the Technical Bulletin area of the Champion Power Equipment internet site.

The part number and recommended minimum altitude for the application of the high altitude carburetor main jet is listed in the table below.

In order to select the correct high altitude main jet it is necessary to identify the carburetor model. For this purpose, a code is stamped on the side of the carburetor. Select the correct main jet part number corresponding to the carburetor code found on your particular carburetor.

Carburetor Code	Main Jet	Part Number	Altitude
P19-1-H	Standard	26.131017.00.H	3500 Feet (1067 Meters)
	Altitude	26.131017.00.01.H	
P19-1-Z	Standard	26.131017.00.Z	
	Altitude	26.131017.00.01.Z	
P19-1-Y	Standard	26.131017.00.Y	
	Altitude	26.131017.00.01.Y	

WARNING

Operation using the alternative main jet at elevations lower than the recommended minimum altitude can damage the engine. For operation at lower elevations, the standard main jet must be used. Operating the engine with the wrong engine configuration at a given altitude may increase its emissions and decrease fuel efficiency and performance.

The owner/operator is responsible for all periodic maintenance.

WARNING

Never operate a damaged or defective chemical pump.

WARNING

Improper maintenance will void your warranty.

NOTE

Maintenance, replacement, or repair of emission control devices and systems may be performed by any non-road engine repair establishment or individual.

Complete all scheduled maintenance in a timely manner. Correct any issue before operating the chemical pump.

NOTE

For service or parts assistance, contact our help line at **1-877-338-0999**.

Engine Maintenance

To prevent accidental starting, remove and ground spark plug wire before performing any service.

Oil

Change oil when the engine is warm. Refer to the oil specification to select the proper grade of oil for your operating environment.

1. Remove the oil drain plug with a 12 mm socket and extension (not included).
2. Allow the oil to drain completely.
3. Replace the drain plug.
4. Remove oil fill cap/dipstick to add oil.
5. Add up to 0.6 qt. (0.6 L) of oil and replace oil fill cap/dipstick. **DO NOT OVERFILL.**
6. Dispose of used oil at an approved waste management facility.

NOTE

Once oil has been added, a visual check should show oil about 1-2 threads from running out of the fill hole. If using the dipstick to check oil level, **DO NOT** screw in the dipstick while checking.

Oil Cont'd.

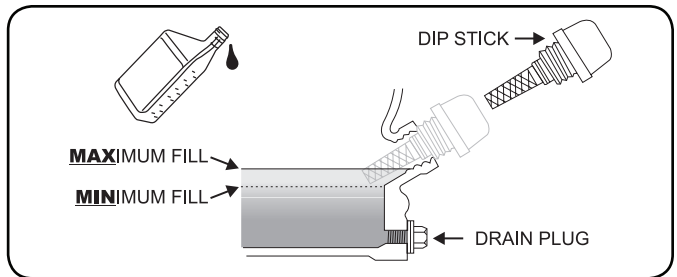

Spark Plugs

1. Remove the spark plug cable from the spark plug.
2. Use the spark plug tool (not included) to remove the plug.
3. Inspect the electrode on the plug. It must be clean and not worn to produce the spark required for ignition.
4. Make certain the spark plug gap is 0.7 - 0.8 mm or (0.028 - 0.031 in.).

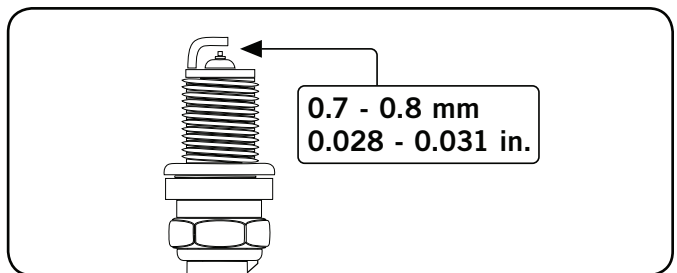

5. Refer to spark plug section on specifications page.
6. Carefully thread the plug into the engine.
7. Use the spark plug tool (not included) to firmly install the plug.
8. Attach the spark plug wire to the plug.

Air Filter

1. Unscrew wing nuts to remove the air filter cover.
2. Remove the foam element.
3. Wash in liquid detergent and water. Squeeze thoroughly dry in a clean cloth.
4. Saturate in clean engine oil.
5. Squeeze in a clean, absorbent cloth to remove all excess oil.
6. Reassemble the element.
7. Reattach the air filter cover and tighten wing nuts.

MAINTENANCE AND STORAGE

Cleaning

⚠ CAUTION

DO NOT spray engine with water.

Water can contaminate the fuel system.

Use a damp cloth to clean exterior surfaces of the engine. Use a soft bristle brush to remove dirt and oil. Use an air compressor (25 PSI) to clear dirt and debris from the engine.

Adjustments

The air-fuel mixture is not adjustable. Tampering with the governor can damage your chemical pump and your electrical devices and will void your warranty. CPE recommends that you contact our service line at **1-877-338-0999** for all other service and/or adjustment needs.

Maintenance Schedule

Follow the service intervals indicated in the following maintenance schedule.

Service your chemical pump more frequently when operating in adverse conditions.

Contact our help line at **1-877-338-0999** to locate the nearest Champion Power Equipment certified service dealer for your chemical pump or engine maintenance needs.

Every 8 hours or daily	
	Check oil level
	Clean around air intake and muffler
First 5 Hours	
	Change oil
Every 50 hours or every season	
	Clean air filter
	Change oil if operating under heavy load or in hot environments
Every 100 hours or every season	
	Change oil
	Clean/Adjust spark plug
	Check/Adjust valve clearance*
	Clean spark arrester
	Clean fuel tank and filter*
Every 250 hours	
	Clean combustion chamber*
Every 3 years	
	Replace fuel line

*To be performed by knowledgeable, experienced owners or Champion Power Equipment certified dealers.

Flushing the Pump

Flush the pump with clean water after each use is advised. This will help to extend the life of the pump as some materials pumped may leave residue that could corrode parts, build up over time, or cause harm to any plants, animals or humans. Flushing the pump will help to reduce any damage and dangers caused by pumping chemicals and pesticides.

Drain Plug

Make sure to unscrew and use the drain plug after each use. By draining the pump, this will help to ensure little to no water is left in the pump and will help prevent damage to the pump if water residue freezes. DO NOT use the Drain Plug during pump operation, as this may cause injury or death.

Storage

For short and long-term storage, please follow these guidelines.

NOTE

Engine switch should be in the "OFF" position while pulling the recoil cord, and performing storage maintenance steps.

Engine Stored for Less than 30 Days

1. Allow the engine to cool completely before storage.
2. Clean engine according to the Maintenance section.
3. To extend the fuel storage life add a properly formulated fuel stabilizer to the tank.
4. Ensure the fuel valve is in the "OFF" position.

Engine Stored for Over 30 Days

1. Add a properly formulated fuel stabilizer to the tank.
2. Run the engine for a few minutes so the treated fuel cycles through the fuel system and carburetor.
3. Turn the fuel valve to the "Off" position.
4. Let the engine run until fuel starvation has stopped the engine. This usually takes a few minutes.
5. The engine needs to cool completely before cleaning and storage.
6. Clean the engine according to the maintenance section.
7. Change the oil.
8. Remove the spark plug and pour about 1/2 ounce (14.8 ml) of oil into the cylinder. Crank the engine slowly to distribute the oil and lubricate the cylinder.
9. Reattach the spark plug.

Chemical Pump Storage

1. Allow the chemical pump to cool completely before storage.
2. Turn off the fuel supply at the fuel valve.
3. Drain the pump chamber thoroughly.
4. Clean the chemical pump according to the instructions in the Maintenance section.
5. Store in a clean, dry place out of direct sunlight.

Winter Storage

Protect your chemical pump parts from freezing.

1. Apply all storage instructions from previous sections.
2. Make sure chemical pump hose is free of all water before storing for winter.

DANGER

Engine exhaust contains odorless and colourless carbon monoxide gas.

To avoid accidental or unintended ignition of the product during periods of storage, the following precautions should be followed:

- When **storing the chemical pump for short or long periods of time** make sure that the Engine Switch and the Fuel Valve are set in the **OFF** position.

NOTE

Our engines work well with 10% or less ethanol blend fuels. When using blended fuels there are some issues worth noting:

- Ethanol-gasoline blends can absorb more water than gasoline alone.
- These blends can eventually separate, leaving water or a watery goo in the tank, fuel valve and carburetor.
- With gravity-fed fuel supplies, this compromised fuel can be drawn into the carburetor and cause damage to the engine and/or potential hazards.
- There are only a few suppliers of fuel stabilizer that are formulated to work with ethanol blend fuels.
- Any damages or hazards caused by using improper fuel, improperly stored fuel, and/or improperly formulated stabilizers, are not covered by manufacture's warranty.

It is advisable to always shut off the fuel supply, run the engine to fuel starvation and drain the tank when the equipment is not in use for more than 30 days.

SPECIFICATIONS

Engine Specifications

- Model YF168F-2-000
- Displacement 196cc
- Type 4-Stroke OHV
- Start Type Recoil

Chemical Pump Specifications

- Model 66526
- Inlet Diameter 2 in. (5.1 cm) NPT
- Outlet Diameter 2 in. (5.1 cm) NPT
- Fuel Capacity 0.9 gal. (3.4 L)
- Total Head 115 ft. (35 m)
- Suction Head 25 ft. (7.5 m)
- Max Delivery Volume 154 gal/min (583 L/min)
- Gross Weight 63.9 lb. (29 kg)
- Net Weight 55.1 lb. (25 kg)
- Height 17.7 in. (44.9 cm)
- Width 16.1 in. (41 cm)
- Length 21.9 in. (55.6 cm)

Fuel

Fuel capacity is 0.9 gal. (3.4 L). Use regular unleaded gasoline with a minimum octane rating of 85 and an ethanol content of no more than 10% by volume.

Oil

Use 10W-30 automotive oil.

Oil capacity is 0.6 qt. (0.6 L).

DO NOT OVERFILL.

Please reference the following chart for recommended oil types for use in the chemical pump.

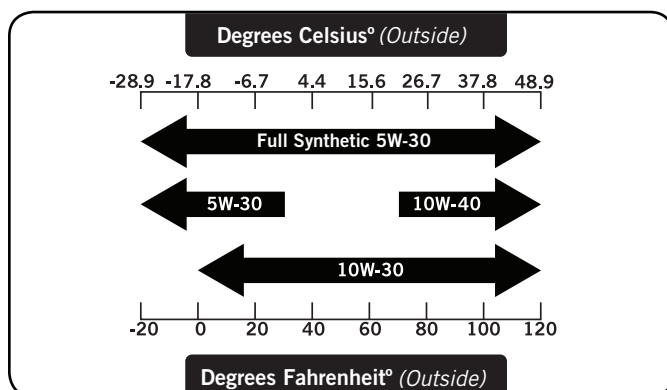

NOTE

Weather will affect engine oil and engine performance. Change the type of engine oil used based on weather conditions to suit the engine needs.

Spark Plugs

OEM spark plug: NHSP F6RTC

Replacement spark plug: NGK BPR6ES or equivalent
Make certain the spark plug gap is 0.7 - 0.8 mm or (0.028 - 0.031 in.).

Maintenance Valve Clearance

- Intake: 0.13 – 0.17 mm (0.005 – 0.007 in.)
 - Exhaust: 0.18 – 0.22 mm (0.007 – 0.009 in.)
- Note: Tech bulletin regarding the valve adjustment procedure is on www.championpowerequipment.com.

An Important Message About Temperature

Your Champion Power Equipment product is designed and rated for continuous operation at ambient temperatures up to 40°C (104°F). When your product is needed your product may be operated at temperatures ranging from -15°C (5°F) to 50°C (122°F) for short periods. If the product is exposed to temperatures outside this range during storage, it should be brought back within this range before operation. In any event, the product must always be operated outdoors, in a well-ventilated area and away from doors, windows and other vents.

Problem	Cause	Solution
Chemical pump will not start	No fuel	Add fuel
	Faulty spark plug	Replace spark plug
Chemical pump will not start; Water transfer pump starts but runs roughly	Low oil level	Fill crankcase to the proper level; place water transfer pump on a flat, level surface
	Choke in the wrong position	Adjust choke
	Spark plug wire loose	Attach wire to spark plug
Chemical pump shuts down during operation	Out of fuel	Fill fuel tank
	Low oil level	Fill crankcase to the proper level; place water transfer pump on a flat, level surface
Chemical pump overheating or performing poorly	Strainer or hose clogged	Remove debris from strainer or hose
	Pump not primed	Re-prime pump
	Suction hose out of water	Place suction hose under the surface of the water
	Head limit exceeded	Relocate pump so suction head is less than discharge head (maximum 98 feet)
	Air leak	Tighten connectors and clamps or replace seal packing
Pump will not draw water	Water not added to pump	Review "Priming the Pump" section of this manual
	Hose clamps on inlet hose are not tight	Even small pinhole leak can result in vacuum loss preventing pump from priming. Check hose clamps to ensure they are tight. Adjust clamp position if necessary.

For further technical support:

Technical Service

Mon – Fri 8:30 AM – 5:00 PM (PST/PDT)

Toll Free: 1-877-338-0999

tech@championpowerequipment.com

SPECIFICATIONS

Parts Diagram

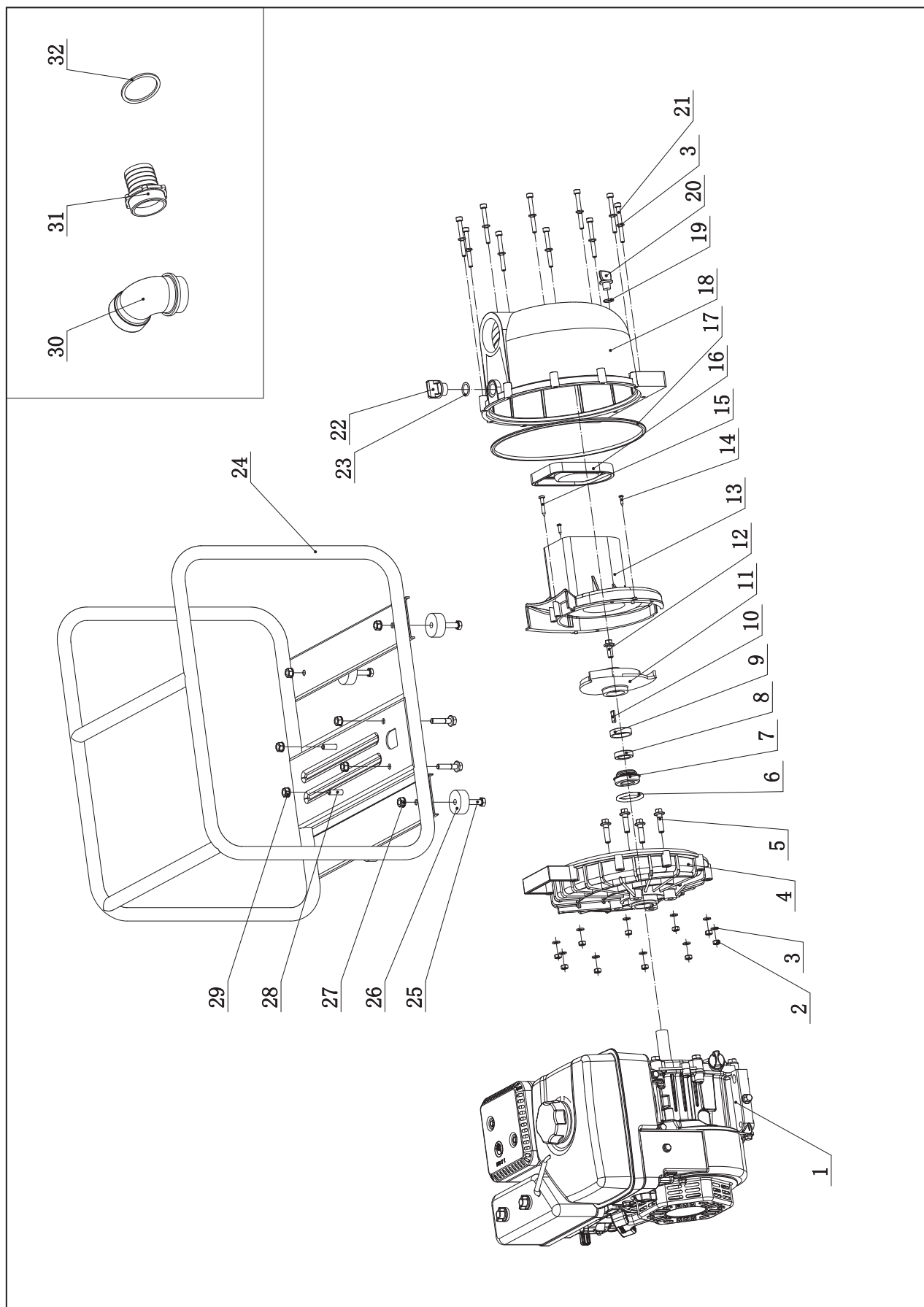

#	Part Number	Description	Qty
1	26.106	Engine	1
2	1.6175.06	Nut M6	10
3	1.97.1.06	Washer Ø6	20
4	222.251303.01	Base, Pump	1
5	2.08.059	Bolt 5/16-24 x 30	4
6	222.251403.03	Seal, Water Seal	1
7	222.250300.01	Water Seal, EPDM + Silicon Carbide	1
8	222.251301.01	Friction-Piece, Silicon Carbide	1
9	222.251302.01	Seal, EPDM	1
10	2.14.021	Key	1
11	222.251106.01	Impeller	1
12	2.08.058	Bolt 5/16-24 x 20	1
13	222.251202.01	Cover, Impeller	1
14	1.845.3516	Screw ST3.5 x 16	2
15	1.845.4845	Screw ST4.8 x 45	1
16	222.251105.01	Valve, One Way	1
17	222.251111.01	Seal, Base Pump	1
18	222.251101.01	Body, Pump	1
19	222.251403.01	Seal, Bottom Plug	1
20	222.251401.01	Plug, Bottom	1
21	1.70.1.0660	Bolt M6 x 60	10
22	222.251401.02	Plug, Upper	1
23	222.251403.02	Seal, Upper Plug	1
24	6.1.114.2	Frame	1
25	1.5783.0825	Bolt M8 x 25	4
26	203.201400.01	Rubber	4
27	1.6177.1.08	Flange Lock Nut M8	4
28	1.5789.0835	Flange Bolt M8 x 35	4
29	1.6187.1.08	Lock Nut M8	4
30	222.251102.02	90 Degree Fitting, 2 in.	1
31	222.251104.02	Straight Fitting, 2 in.	2
32	222.251103.01	Seal, Fitting	3

SPECIFICATIONS

Engine Parts Diagram

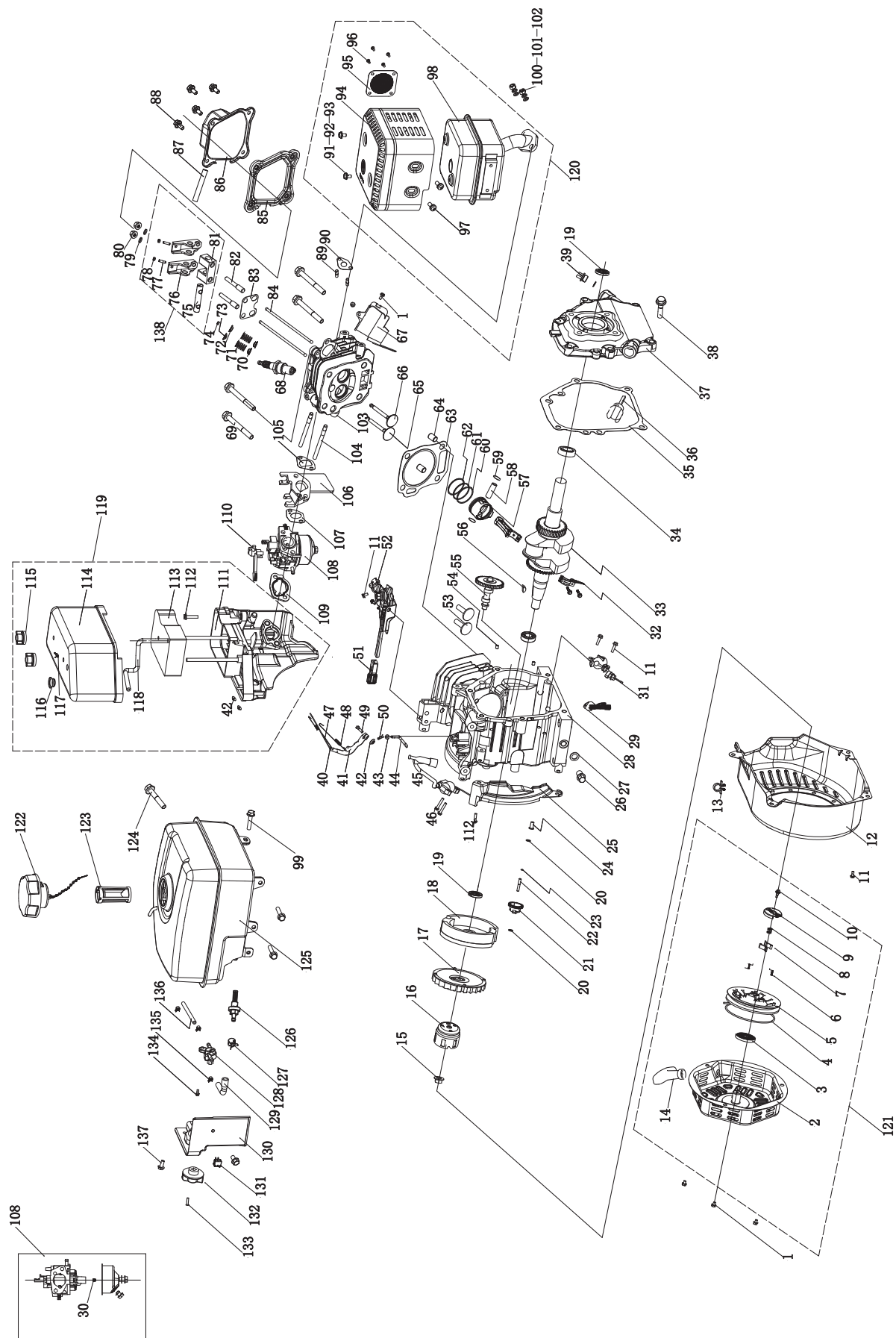

#	Part Number	Description	Qty
1	1.5789.0608	Flange Bolt M6 x 8	5
2	22.061100.00.2	Cover, Recoil Starter, Black	1
3	21.061005.00	Spring, Recoil Starter	1
4	2.10.003.1	Rope Ø4 x 1550, Black	1
5	21.061001.01	Reel, Recoil Starter	1
6	45.060003.00	Spring, Ratchet	2
7	45.060002.00	Starter Ratchet, Steel	2
8	45.060009.00	Spring, Ratchet Guide	1
9	45.060007.00	Ratchet Guide	1
10	45.060008.00	Screw, Ratchet Guide	1
11	1.5789.0612	Flange Bolt M6 x 12	8
12	24.080100.01.48	Fan Cover, Yellow	1
13	2.05.002	Clamp Ø9.5 x 5	1
14	21.061300.00	Handle, Recoil, Soft	1
15	2.02.006	Nut M14 x 1.5	1
16	21.060001.01	Pulley, Starter	1
17	23.080001.00	Cooling Fan	1
18	24.120100.06	Flywheel	1
19	2.11.001	Oil Seal Ø25 x Ø41.3 x 6	2
20	2.03.020.1	Washer Ø6.2 x Ø15 x 0.5, Black	2
21	21.110100.00	Gear, Governor	1
22	21.110013.00	Shaft, Governor Gear	1
23	21.110011.00	Clip, Governor Gear	1
24	21.110012.01	Bushing, Governor Gear, Steel	1
25	23.080600.00	Air Guide, Right	1
26	2.08.037	Drain Bolt M10 x 1.25 x 25	2
27	2.03.016	Washer Ø10 x Ø16 x 1.5, Drain Bolt	2
28	26.030100.00	Crankcase	1
29	21.120400.01	Diode Assembly	1
30	26.131017.00	Main Jet, Standard	1
	26.131017.00.01	Main Jet, Altitude	/
31	21.127000.02	Oil Level Sensor	1
32	23.050200.00	Connecting Rod	1
33	25.050100.03	Crankshaft	1
34	1.276.6205	Bearing 6205	2
35	24.030008.00	Gasket, Crankcase Cover	1
36	22.031000.00.48	Oil Dipstick Assembly, Yellow	1
37	24.030007.00	Cover, Crankcase	1
38	1.5789.0832	Flange Bolt M8 x 32	6
39	22.031000.01.48	Oil Filter Cap, Yellow	1
40	23.110005.01	Spring, Throttle Return	1
41	21.110003.00	Arm, Governor	1
42	1.6177.06	Flange Nut M6	3
43	2.03.021.1	Washer Ø6.4 x Ø13 x 1, Black	1
44	21.110001.00	Shaft, Governor Arm	1
45	22.123000.01	Ignition Coil, Silicon Rubber	1
46	1.5789.0625	Flange Bolt M6 x 25	2
47	23.110006.00	Rod, Governor	1
48	23.110007.00	Spring, Governor	1
49	2.08.040	Bolt M6 x 21, Governor Arm	1
50	21.110008.00	Pin, Shaft	1
51	24.111008.01.48	Grip Sheath, Speed Governor, Yellow	1
52	24.111000.01	Control Assembly	1
53	25.040013.00	Lifter, Valve	2
54	2.04.001	Dowel Pin Ø9 x 14	2
55	26.041000.01	Camshaft	1
56	2.14.012	Woodruff Key 4 x 7.5 x 19	1
57	26.050005.00	Piston	1
58	23.050003.00	Pin, Piston	1
59	2.09.001	Circlip Ø18 x Ø1	2
60	26.050303.00	Ring, Oil	1
61	26.050302.00	Ring, Second Piston	1
62	26.050301.00	Ring, First Piston	1
63	26.030009.00	Gasket, Cylinder Head	1
64	2.04.003	Dowel Pin Ø10 x 14	2
65	23.040002.00	Valve, Intake	1
66	23.040006.00	Valve, Exhaust	1
67	26.080400.00	Air Guide, Lower	1
68	2.15.002(F6RTC)	Spark Plug F6RTC	1
69	1.5789.0860	Flange Bolt M8 x 60	4

#	Part Number	Description	Qty
70	23.040017.00	Oil Seal, Valve	2
71	21.040003.00	Spring, Valve	2
72	21.040007.00	Retainer, Exhaust Valve Spring	1
73	21.040001.00	Retainer, Intake Valve Spring	1
74	21.040008.00	Rotator, Exhaust Valve	1
75	24.040202.00	Shaft, Rocker Arm	1
76	22.040009.00	Rocker Arm	2
77	22.040012.00	Screw, Valve Adjustment	2
78	21.040021.00	Nut M6 x 0.5, Lock	2
79	1.97.1.06	Washer Ø6	2
80	1.6177.1.06	Flange Nut M6	2
81	24.040201.00	Retainer, Rocker Arm	1
82	23.040010.00	Bolt, Rocker Arm	2
83	24.040004.00	Guide Plate, Push Rod	1
84	23.040005.00	Push Rod	2
85	21.020002.01	Gasket, Cylinder Head Cover	1
86	24.021000.00	Cover, Cylinder Head	1
87	21.020001.00	Breather Tube	1
88	1.5789.0615	Flange Bolt M6 x 15	4
89	2.01.010	Stud Bolt M8 x 35	2
90	26.100001.00	Gasket, Exhaust Pipe	1
91	1.16674.0510	Flange Bolt M5 x 10	2
92	1.848.05	Washer Ø5	2
93	1.93.05	Lock Washer Ø5	2
94	24.101202.00	Muffler Protector	1
95	46.101300.05	Muffler Screen	1
96	1.818.0406	Screw M4 x 6	4
97	1.9074.4.0510	Screw/Washer Assembly M5 x 10	2
98	24.101100.00	Muffler	1
99	2.08.154	Flange Bolt Assembly M6 x 20	3
100	1.6175.08	Nut M8	2
101	1.848.08	Washer Ø8	2
102	1.93.08	Lock Washer Ø8	2
103	26.010100.00	Cylinder Head	1
104	2.01.009	Stud Bolt M6 x 110	2
105	24.130002.00	Gasket, Insulator	1
106	23.130001.00	Insulator, Carburetor	1
107	22.130003.00	Gasket, Carburetor	1
108	26.131000.00	Carburetor	1
	26.131000.02		
109	21.130004.00	Gasket, Air Cleaner	1
110	21.130100.00	Choke Handle	1
111	24.091100.01	Base, Air Cleaner	1
112	1.5789.0620	Flange Bolt M6 x 20	2
113	24.091003.02	Element, Air Cleaner	1
114	24.091200.00	Cover, Air Cleaner	1
115	24.091600.01	Screw Cap, Air Clean Cover	2
116	2.12.001	Buffer Ø7.5 x 7.5	1
117	2.06.006	Clamp Ø7 x Ø1	1
118	24.070014.02	Pipe, Reversal Valve	1
119	24.091000.00	Air Cleaner Assembly	1
120	24.101000.00	Muffler Assembly	1
121	22.061000.00	Recoil Assembly	1
122	24.070100.02	Cap, Fuel Tank	1
123	81.070301.00	Fuel Filter, Fuel Tank	1
124	2.08.156	Flange Bolt Assembly M6 x 33	1
125	24.071000.01	Fuel Tank	1
126	21.070600.03	Connect, Zinc Alloy	1
127	2.06.016	Clamp Ø8.7 x b8	1
128	24.070400.00	Fuel Valve	1
129	24.070011.01	Pipe Ø4.5 x (30 + 30)	1
130	24.070010.00	Veil, Fuel Tank	1
131	5.1010.003.3	Ignition Switch, Red	1
132	24.070001.00	Fuel Knob	1
133	1.818.0412	Bolt M4 x 12	1
134	1.16674.0512.2	Flange Bolt M5 x 12	1
135	2.06.007	Clamp Ø8 x b6	3
136	24.070011.00	Fuel Pipe Ø4.5 x Ø9.5 x 230	1
137	1.5789.0612.3	Flange Bolt M6 x 12	2
138	24.040200.00	Rocker Arm Assembly	1

WARRANTY

WARRANTY*

CHAMPION POWER EQUIPMENT
2 YEAR LIMITED WARRANTY

Warranty Qualifications

Champion Power Equipment (CPE) will register this warranty upon receipt of your Warranty Registration Card and a copy of your sales receipt from one of CPE's retail locations as proof of purchase. Please submit your warranty registration and your proof of purchase within ten (10) days of the date of purchase.

Repair/Replacement Warranty

CPE warrants to the original purchaser that the mechanical and electrical components will be free of defects in material and workmanship for a period of two years (parts and labor) from the original date of purchase and 180 days (parts and labor) for commercial and industrial use. Transportation charges on product submitted for repair or replacement under this warranty are the sole responsibility of the purchaser. This warranty only applies to the original purchaser and is not transferable.

Do Not Return The Unit To The Place Of Purchase

Contact CPE's Technical Service and CPE will troubleshoot any issue via phone or e-mail. If the problem is not corrected by this method, CPE will, at its option, authorize evaluation, repair or replacement of the defective part or component at a CPE Service Center. CPE will provide you with a case number for warranty service. Please keep it for future reference. Repairs or replacements without prior authorization, or at an unauthorized repair facility, will not be covered by this warranty.

Warranty Exclusions

This warranty does not cover the following repairs and equipment:

Normal Wear

Products with mechanical and electrical components need periodic parts and service to perform well. This warranty does not cover repair when normal use has exhausted the life of a part or the equipment as a whole.

Installation, Use and Maintenance

This warranty will not apply to parts and/or labor if the product is deemed to have been misused, neglected, involved in an accident, abused, loaded beyond the product's limits, modified, installed improperly or connected incorrectly to any electrical component. Normal maintenance is not covered by this warranty and is not required to be performed at a facility or by a person authorized by CPE.

Other Exclusions

This warranty excludes:

- Cosmetic defects such as paint, decals, etc.
- Wear items such as filter elements, o-rings, etc.
- Accessory parts such as starting batteries, and storage covers.
- Failures due to acts of God and other force majeure events beyond the manufacturer's control.
- Problems caused by parts that are not original Champion Power Equipment parts.

When applicable, this warranty does not apply to products used for prime power in place of a utility.

Limits of Implied Warranty and Consequential Damage

Champion Power Equipment disclaims any obligation to cover any loss of time, use of this product, freight, or any incidental or consequential claim by anyone from using this product. THIS WARRANTY AND THE ATTACHED U.S. EPA, CARB and/or ECCC EMISSION CONTROL SYSTEM WARRANTIES (WHEN APPLICABLE) ARE IN LIEU OF ALL OTHER WARRANTIES, EXPRESS OR IMPLIED, INCLUDING WARRANTIES OF MERCHANTABILITY OR FITNESS FOR A PARTICULAR PURPOSE.

A unit provided as an exchange will be subject to the warranty of the original unit. The length of the warranty governing the exchanged unit will remain calculated by reference to the purchase date of the original unit.

This warranty gives you certain legal rights which may change from state to state or province to province. Your state or province may also have other rights you may be entitled to that are not listed within this warranty.

Contact Information

Address

Champion Power Equipment, Inc.
Customer Service
12039 Smith Ave.
Santa Fe Springs, CA 90670 USA
www.championpowerequipment.com

Customer Service

Mon – Fri 8:30 AM – 5:00 PM (PST/PDT)
Toll Free: 1-877-338-0999
info@championpowerequipment.com
Fax no.: 1-562-236-9429

Technical Service

Mon – Fri 8:30 AM – 5:00 PM (PST/PDT)
Toll Free: 1-877-338-0999
tech@championpowerequipment.com
24/7 Tech Support: 1-562-204-1188

*Except as otherwise stipulated in any of the following enclosed Emission Control System Warranties (when applicable) for the Emission Control System: U.S. Environment Protection Agency (EPA), California Air Resources Board (CARB) and/or Environment and Climate Change Canada (ECCC).

**Champion Power Equipment, Inc. (CPE),
United States Environment Protection Agency (U.S. EPA)
Emission Control System Warranty**

Your Champion Power Equipment (CPE) engine complies with U.S. EPA emission regulations.

YOUR WARRANTY RIGHTS AND OBLIGATIONS:

The US EPA AND CPE are pleased to explain the Federal Emission Control Systems Warranty on your 2018 small off-road engine (SORE) and engine powered equipment. New engines and equipment must be designed, built and equipped, at the time of sale, to meet U.S. EPA regulations for small off-road engines (SORE). CPE warrants the emission control system on your small off-road engine (SORE) and equipment for the period of time listed below, provided there has been no abuse, neglect, unapproved modification, or improper maintenance of your equipment.

Your emission control system may include parts such as the carburetor, fuel-injection system, the ignition system, catalytic converter and fuel lines. Also included may be hoses, belts, connectors and other emission related assemblies. Where a warrantable condition exists, CPE will repair your small off-road engine (SORE) at no cost to you including diagnosis, parts and labor.

MANUFACTURER'S EMISSION CONTROL SYSTEM WARRANTY COVERAGE:

This emission control system is warranted for two years, subject to provisions set forth below. If, during the warranty period, an emission related part on your engine is defective in materials or workmanship, the part will be repaired or replaced by CPE.

OWNER WARRANTY RESPONSIBILITIES:

As the small off-road engine (SORE) owner, you are responsible for the performance of the required maintenance listed in your Owner's Manual. CPE recommends that you retain all your receipts covering maintenance on your small off-road engine, but CPE cannot deny warranty solely for the lack of receipts or for your failure to ensure the performance of all scheduled maintenance.

As the small off-road engine (SORE) owner, you should however be aware that CPE may deny you warranty coverage if your small, off-road engine (SORE) or a part has failed due to abuse, neglect, improper maintenance or unapproved modifications.

You are responsible for presenting your small off-road engine (SORE) to an Authorized CPE service outlet or alternate service outlet as described in (3)(f.) below, CPE dealer or CPE, Santa Fe Springs, Ca. as soon as a problem exists. The warranty repairs should be completed in a reasonable amount of time, not to exceed 30 days.

If you have any questions regarding your warranty rights and responsibilities, you should contact:

Champion Power Equipment, Inc.
Customer Service
12039 Smith Ave.
Santa Fe Springs, CA 90670
1-877-338-0999
tech@championpowerequipment.com

EMISSION CONTROL SYSTEM WARRANTY

The following are specific provisions relative to your Emission Control System (ECS) Warranty Coverage.

1. APPLICABILITY: This warranty shall apply to 1997 and later model year small off-road engines (SORE). The ECS Warranty Period shall begin on the date the new engine or equipment is delivered to its original, end-use purchaser, and shall continue for 24 consecutive months thereafter.

2. GENERAL EMISSIONS WARRANTY COVERAGE

CPE warrants to the original, end-use purchaser of the new engine or equipment and to each subsequent purchaser that each of its small off-road engines (SORE) is:

- a. Designed, built and equipped so as to conform to U.S. EPA emissions standards for spark-ignited engines at or below 19 kilowatts.
- b. Free from defects in materials and workmanship that cause the failure of a warranted part to be identical in all material respects to the part as described in the engine manufacturer's application for certification for a period of two years.

3. THE WARRANTY ON EMISSION-RELATED PARTS WILL BE INTERPRETED AS FOLLOWS:

a. Any warranted part that is not scheduled for replacement as required maintenance in the Owners Manual shall be warranted for the ECS Warranty Period. If any such part fails during the ECS Warranty Period, it shall be repaired or replaced by CPE according to Subsection "d" below. Any such part repaired or replaced under the ECS Warranty shall be warranted for any remainder of the ECS Warranty Period.

b. Any warranted, emissions-related part which is scheduled only for regular inspection as specified in the Owners Manual shall be warranted for the ECS Warranty Period. A statement in such written instructions to the effect of "repair or replace as necessary", shall not reduce the ECS Warranty Period. Any such part repaired or replaced under the ECS Warranty shall be warranted for the remainder of the ECS Warranty Period.

c. Any warranted, emissions-related part which is scheduled for replacement as required maintenance in the Owner's Manual shall be warranted for the period of time prior to the first scheduled replacement point for that part. If the part fails prior to the first scheduled replacement, the part shall be repaired or replaced by CPE according to Subsection "d" below. Any such emissions-related part repaired or replaced under the ECS Warranty, shall be warranted for the remainder of the ECS Warranty Period prior to the first scheduled replacement point for such emissions-related part.

d. Repair or replacement of any warranted, emissions-related part under this ECS Warranty shall be performed at no charge to the owner at a CPE Authorized Service Outlet.

e. The owner shall not be charged for diagnostic labor which leads to the determination that a part covered by the ECS Warranty is in fact defective, provided that such diagnostic work is performed at a CPE Authorized Service Outlet.

f. CPE shall pay for covered emissions warranty repairs at non-authorized service outlets under the following circumstances:

i. The service is required in a population center with a population over 100,000 according to U.S. Census 2000 without a CPE Authorized Service Outlet AND

ii. The service is required more than 100 miles from a CPE Authorized Service Outlet. The 100 mile limitation does not apply in the following states: Alaska, Arizona, Colorado, Hawaii, Idaho, Montana, Nebraska, Nevada, New Mexico, Oregon, Texas, Utah and Wyoming.

g. CPE shall be liable for damages to other original engine components or approved modifications proximately caused by a failure under warranty of an emission-related part covered by the ECS Warranty.

h. Throughout the ECS Warranty Period, CPE shall maintain a supply of warranted emission-related parts sufficient to meet the expected demand for such emission-related parts.

i. Any CPE Authorized and approved emission-related replacement part may be used in the performance of any ECS Warranty maintenance or repair and will be provided without charge to the owner. Such use shall not reduce CPE's warranty obligation.

j. Unapproved add-on or modified parts may not be used to modify or repair a CPE engine. Such use voids this ECS Warranty and shall be sufficient grounds for disallowing an ECS Warranty claim. CPE shall not be liable hereunder for failures of any warranted parts of a CPE engine caused by the use of such an unapproved add-on or modified part.

EMISSION-RELATED PARTS INCLUDE THE FOLLOWING: (using those portions of the list applicable to the engine)

Systems covered by this warranty	Parts Description
Fuel Metering System	Fuel regulator, Carburetor and internal parts
Air Induction System	Air cleaner, Intake manifold
Ignition System	Spark plug and parts, Magneto ignition system
Exhaust System	Exhaust manifold, catalytic converter
Miscellaneous Parts	Tubing, Fittings, Seals, Gaskets, and Clamps associated with these listed systems.
Evaporative Emissions	Fuel Tank, Fuel Cap, Fuel Line, Fuel Line Fittings, Clamps, Pressure Relief Valves, Control Valves, Control Solenoids, Electronic Controls, Vacuum Control Diaphragms, Control Cables, Control Linkages, Purge Valves, Vapor Hoses, Liquid/Vapor Separator, Carbon Canister, Canister Mounting Brackets, Carburetor Purge Port Connector

TO OBTAIN WARRANTY SERVICE:

You must take your CPE engine or the product on which it is installed, along with your warranty registration card or other proof of original purchase date, at your expense, to any Champion Power Equipment dealer who is authorized by Champion Power Equipment, Inc. to sell and service that CPE product during his normal business hours. Alternate service locations defined in Section (3)(f.) above must be approved by CPE prior to service. Claims for repair or adjustment found to be caused solely by defects in material or workmanship will not be denied because the engine was not properly maintained and used.

If you have any questions regarding your warranty rights and responsibilities, or to obtain warranty service, please write or call Customer Service at Champion Power Equipment, Inc.

**Champion Power Equipment, Inc.
12039 Smith Ave.
Santa Fe Springs, CA 90670
1-877-338-0999
Attn.: Customer Service
tech@championpowerequipment.com**