

CHAMPION

POWER EQUIPMENT TM-MC

OPERATOR'S MANUAL

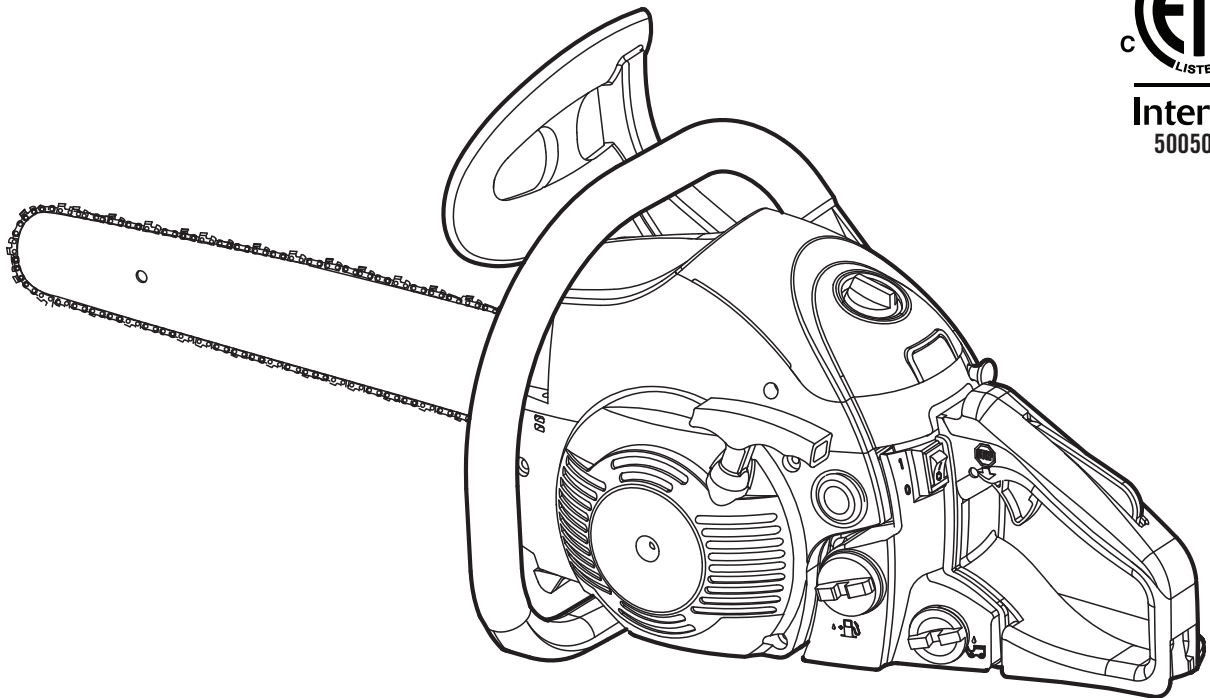

CHAINSAW



MODEL NUMBER
100283

SAVE THESE INSTRUCTIONS
Important safety instructions
are included in this manual.

MADE IN CHINA
REV 100283-20170317

12039 Smith Ave.
Santa Fe Springs CA 90670
USA / 1-877-338-0999
www.championpowerequipment.com

Have questions or need assistance?

Do not return this product to the store!

WE ARE HERE TO HELP!

Visit our website:

www.championpowerequipment.com

for more info:

- Product Info & Updates
- Tech Bulletins
- Frequently Asked Questions
- Product Registration

– or –

Call our Customer Care Team Toll-Free at:

1-877-338-0999

Parts Ordering:

Mon – Fri 8:30 AM – 5:00 PM (PST/PDT)

Toll Free: 1-877-338-0999

*We are always working to improve our products. Therefore, the enclosed product may differ slightly from the image on the cover.

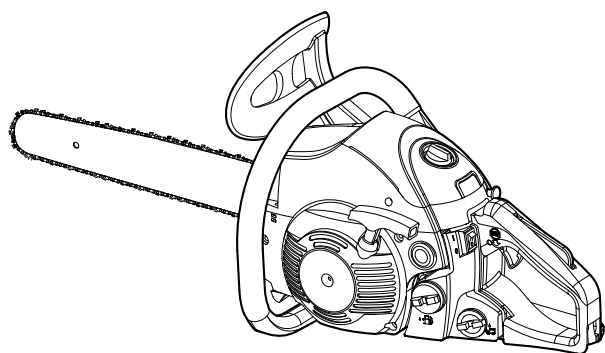

CHAINSAW

TABLE OF CONTENTS

Introduction	1	Limbing	17
Manual Conventions	2	Bucking: Safety	17
Safety Rules	3	Bucking: Procedure	17
Spark Arrestor Note	3	Cutting Logs Under Stress	17
Read All Instructions Before Operating	3	Cutting Fully Supported Logs	17
Safety Warnings for Gas Units	3	Overbucking	17
While Operating	3	Underbucking	17
Kickback Safety	5	Pruning	18
Understanding Kickback	5	Maintenance and Storage	19
Linear Kickback	5	Maintenance Schedule	19
Pull-in	5	Adding Bar and Chain Oil	19
Kickback Safety Precautions	5	Adjusting the Bar and Chain Oil Flow	20
Other Safety Warnings	6	Adjusting the Chain Tension	20
Safety and International Symbols	7	Removing and Installing the Guide Bar and Saw Chain	21
Starting Instructions Symbols	8	Removing the Guide Bar and Saw Chain	22
Controls and Features	9	Installing the Guide Bar and Saw Chain	22
Safety Features	9	Maintaining the Saw Chain	23
Assembly	10	Sharpening the Saw Chain	23
Adding Bar and Chain Oil: Initial Use	10	Maintaining the Guide Bar	24
Adjusting the Chain Tension: Initial Use	10	Lubricating the Guide Bar Sprocket Tip	25
Testing the Chain Brake	10	Replacing the Guide Bar and Saw Chain	25
Oil and Fuel Mixing Instructions	10	Maintaining the Air Filter	25
Definition of Blended Fuels	10	Cleaning the Air Filter	25
Using Fuel Additives	10	Adjusting the Idle Speed	26
Mixing the Fuel	11	Maintaining the Spark Plug	26
Operation	12	Cleaning	27
Starting or Stopping	12	Storage	28
Starting Instructions	12	Specifications	29
Stopping Instructions	13	Chainsaw Specifications	29
Emergency Stopping	13	Replacement Parts	29
Tips for Best Results	13	Parts Diagram	31
Preparing the Work Area	14	Parts List	32
Holding the Unit	14	Engine Parts Diagram	33
Cutting Procedure Basics	14	Engine Parts List	34
Felling: Safety	15	Troubleshooting	35
Felling Procedure	15	Warranty	36
Step 1: Removing Buttress Roots	15		
Step 2: Making the Notched Undercut	15		
Step 3: Making the Felling Back Cut	16		

INTRODUCTION

Congratulations on your purchase of a Champion Power Equipment product. Champion Power Equipment and Champion Engine Technology designs, builds, and supports all of our products to strict specifications and guidelines. With proper product knowledge, safe use, and regular maintenance, this product should bring years of satisfying service.

Every effort has been made to ensure the accuracy and completeness of the information in this manual, and we reserve the right to change, alter and/or improve the product and this document at any time without prior notice.

Since CPE/CET highly value how our products are designed, manufactured, operated and are serviced, and also highly value your safety and the safety of others, we would like you to take the time to review this product manual and other product materials thoroughly and be fully aware and knowledgeable of the assembly, operation, dangers and maintenance of the product before use. Fully familiarize yourself, and make sure others who plan on operating the product fully familiarize themselves too, with the proper safety and operation procedures before each use. Please always exercise common sense and always err on the side of caution when operating the product to ensure no accidents, property damage, or injury occurs. We want you to continue to use and be satisfied with your CPE/CET product for years to come.

Record the model and serial numbers as well as date and place of purchase for future reference. Have this information available when ordering parts and when making technical or warranty inquiries.

Champion Power Equipment Support
1-877-338-0999
Model Number
100283
Serial Number
Date of Purchase
Purchase Location
For Oil Type see 'Add Engine Oil' section. For Fuel Type see 'Add Fuel' section.

This manual uses the following symbols to help differentiate between different kinds of information. The safety symbol is used with a key word to alert you to potential hazards in operating and owning power equipment.

Follow all safety messages to avoid or reduce the risk of serious injury or death.

 **DANGER**

DANGER indicates an imminently hazardous situation which, if not avoided, **will** result in death or serious injury.

 **WARNING**

WARNING indicates a potentially hazardous situation which, if not avoided, **could** result in death or serious injury.

 **CAUTION**

CAUTION indicates a potentially hazardous situation which, if not avoided, **may** result in minor or moderate injury.

CAUTION

CAUTION used without the safety alert symbol indicates a potentially hazardous situation which, if not avoided, **may** result in property damage.

 **NOTICE**

If you have questions regarding your chainsaw, we can help. Please call our help line at **1-877-338-0999**

SAFETY RULES

Read the operator's manual and follow all warnings and safety instructions. Failure to do so can result in serious injury to the operator and/or bystanders.

Spark Arrestor Note

NOTICE

For users on U.S. Forest Land and in the states of California, Maine, Oregon and Washington. All U.S. Forest Land and the state of California (Public Resources Codes 4442 and 4443), Oregon and Washington require, by law that certain internal combustion engines operated on forest brush and/or grass-covered areas be equipped with a spark arrestor, maintained in effective working order, or the engine be constructed, equipped and maintained for the prevention of fire. Check with your state or local authorities for regulations pertaining to these requirements. Failure to follow these requirements could subject you to liability or a fine. This unit is factory equipped with a spark arrestor. Replacement requires a Muffler Assembly, installed at a Champion Parts & Repair Service Center.

Read All Instructions Before Operating

WARNING

When using the unit, all safety rules must be followed. Please read these instructions before operating the unit in order to ensure the safety of the operator and any bystanders. Please keep these instructions for later use.

- Read the instructions carefully. Be familiar with the controls and proper use of the unit. Know how to stop the unit and disengage the controls quickly.
- Do not operate this unit when tired, ill or under the influence of alcohol, drugs or medication.

WARNING

Fatigue causes carelessness. Be more cautious before rest periods and towards the end of your shift.

- Never allow children to operate the unit. Never allow adults to operate the unit without proper instruction.
- All guards and safety attachments must be installed properly before operating the unit.
- Inspect the unit before use. Replace damaged parts. Check for fuel leaks. Make sure all fasteners are in place and secure. Replace parts that are cracked, chipped, or damaged in anyway. Do not operate the unit with loose or damaged parts.

Read All Instructions Before Operating Cont'd.

- Be aware of risk of injury to the head, hands and feet.
- Carefully inspect the area before starting the unit. Remove rocks, broken glass, nails, wire, string and other objects that may be thrown or become entangled with the unit.
- Clear the area of children, bystanders and pets; keep them outside a 50-foot (15m) radius, at a minimum. Even then, they are still at risk from thrown objects. Encourage bystanders to wear eye protection. If you are approached, stop the unit immediately.
- Squeeze the throttle control and check that it returns automatically to the idle position. Make all adjustments or repairs before using the unit.

Safety Warnings For Gas Units

WARNING

Use caution when handling fuel. Gasoline is highly flammable and its vapors can explode if ignited. Take the following precautions:

- Store fuel only in containers specifically designed and approved for the storage of such materials.
- Always stop the engine and allow it to cool before filling the tank. Never remove the fuel tank cap or add fuel when the engine is hot. Always loosen the fuel tank cap slowly to relieve any pressure in the tank before fueling.
- Always mix and add fuel in a clean, well-ventilated outdoor area where there are no sparks or flames. DO NOT smoke.
- Never operate the unit without the fuel cap securely in place.
- Avoid creating a source of ignition for spilled fuel. Wipe up any spilled fuel from the unit immediately, before starting the unit. Move the unit at least 30 ft. (9.1 m) from the fueling source and site before starting the engine. DO NOT smoke.
- Never start or run the unit inside a closed room or building. Breathing exhaust fumes can kill. Operate this unit only in a well ventilated outdoor area.

While Operating

- When a chainsaw is being used, a fire extinguisher should be available.
- Wear safety glasses or goggles that meet current ANSI Z87.1 standards and are marked as such. Wear ear/hearing protection when operating this unit.

While Operating Cont'd.

- Wear a face mask or dust mask if the operation is dusty. Use a hard hat or other type of safety helmet.
- Wear safety boots and protective gloves. Wear heavy, snug-fitting clothes, including long pants and a long-sleeve shirt. Do not wear loose clothing, jewelry, short pants, sandals or go barefoot. Secure hair above shoulder level.
- Make sure the saw chain is not in contact with anything before starting the unit.
- Use the unit only in daylight or good artificial light.
- Avoid accidental starting. Be in the starting position whenever pulling the starter rope. The operator and unit must be in a stable position while starting. Refer to Starting and Stopping.
- Use the right tool. Only use this tool for its intended purpose: to cut wood. Do not use the unit for cutting plastic, masonry or other non-wood building materials. Only use the unit as described in this manual.
- Keep all body parts away from the saw chain when the unit is running. Do not touch or try to stop moving parts.
- When carrying a chainsaw with the engine running, engage the chain brake.
- Do not touch the engine or muffler. These parts get extremely hot from operation, even after the unit is turned off.
- Do not operate the unit faster than the speed needed to do the job. Do not run the unit at high speed when not in use.
- Do not force the unit, especially near the end of a cut. It will do a better, safer job when used at the intended rate.
- Always turn the engine off when operation is delayed, when setting the unit down or when carrying the unit from one location to another. Make sure all moving parts come to a complete stop.
- Carry the unit by the front handle with the muffler positioned away from the body and the guide bar positioned to the rear. Cover the guide bar and saw chain with the scabbard when carrying the unit.
- If you strike or become entangled with a foreign object, stop the unit immediately and check for damage. Do not operate the unit before repairing damage. Do not operate the unit with loose or damaged parts.
- Use only original equipment manufacturer (OEM)

While Operating Cont'd.

- replacement parts and accessories for this unit. These are available from Champion or other qualified service dealer. Use of any other parts or accessories could lead to serious injury to the user, or damage to the unit, and void the warranty.
- Keep the unit clean. Carefully remove vegetation and other debris that could block moving parts.
- To reduce fire hazard, replace a faulty muffler and spark arrestor. Keep the engine and muffler free from grass, leaves, excessive grease or carbon build up.
- If the unit starts to vibrate abnormally, stop the unit immediately. Inspect the unit for the cause of the vibration. Vibration is generally an indicator of trouble.
- Keep the work area clean. Cluttered areas invite injuries. Do not start cutting until the work area is clear and free from obstructions. Make sure there is secure footing and a planned retreat path from falling trees or branches.
- Do not cut near electrical cables or power lines. Keep at least 50 feet (15 m) away from all power lines.
- For safer, more effective performance, make sure the guide bar and chain are properly cleaned, lubricated, tightened and sharpened. Check the guide bar and chain at frequent intervals for proper adjustment.
- When cutting a limb that is under tension, use extreme caution. When the tension is released, the limb could spring back and strike the operator, causing severe injury or death.
- Use extreme caution when cutting small-sized brush and saplings, as slender material may catch the saw chain and be whipped toward the operator or pull the operator off balance.
- This saw is classified by UL as a Class 1C saw in accordance with CSA Z62.1-03. It is intended for infrequent use by homeowners, cottagers and campers, and for general applications such as clearing, pruning, cutting firewood, etc. It is not intended for prolonged use. If the intended use involves prolonged periods of operation, this may cause circulatory problems in the user's hands due to vibration.
- Do not operate the unit in a tree or on a ladder unless specifically trained to do so.
- Never remove, modify or make inoperative any safety device furnished with the unit.
- Do not use the unit in the presence of flammable liquids or gases.

SAFETY RULES

- Do not attempt operations beyond the operator's capacity or experience.
- Do not operate a unit that is damaged, improperly adjusted or not completely and securely assembled. Make sure moving parts stop when the throttle control trigger is released or the unit is turned off. Do not use the unit if it does not turn on and off properly. Have defective parts replaced by Champion or other qualified service dealer.

Kickback Safety

WARNING

Kickback may occur when the nose or tip of the guide bar touches an object, or when the wood closes in and pinches the saw chain in the cut. In some cases, tip contact may cause a lightning-fast reverse action, kicking the guide bar rapidly back towards the operator. Pinching the saw chain along the top of the guide bar may push the guide bar rapidly back towards the operator. Either of these reactions may cause a loss of control over the saw, which could result in serious injury to the user. Contact with foreign objects within the wood can also induce a loss of chain saw control.

Understanding Kickback

A basic understanding of kickback can help reduce or eliminate the element of surprise and the chance of kickback-related injury. Sudden surprise contributes to accidents.

- **Rotational Kickback** can happen when the upper tip of the guide bar contacts an object while the chain is moving (Fig. A). This can cause the chain to dig into the object and momentarily stop moving. The guide bar is then kicked up and back toward the operator in a lightning-fast reverse reaction.
- **Linear Kickback** can happen when the wood on either side of a cut closes in and pinches the moving saw chain along the top of the guide bar (Fig. B). This can cause the chain to instantly stop. The chain force is then reversed, causing the saw to move in the opposite direction, sending the saw straight back toward the operator.
- **Pull-In** can happen when the moving chain on the bottom of the guide bar hits a foreign object inside the wood. This can cause the chain to suddenly stop. The saw is then pulled forward and away from the operator, which could potentially result in the loss of control of the saw.

Understanding Kickback Cont'd.

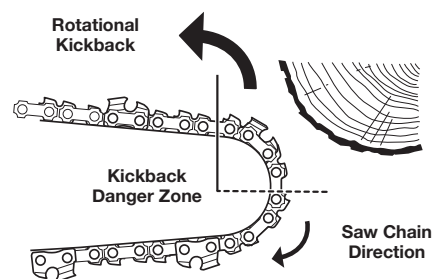

Fig. A

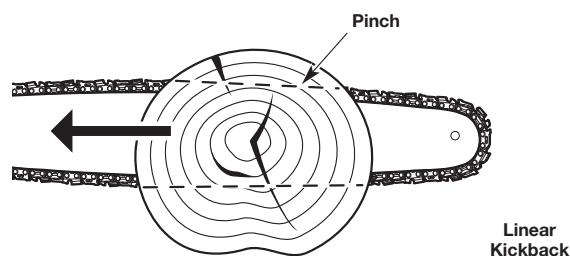

Fig. B

Kickback Safety Precautions

Take the following steps to reduce the chance of accident or injury:

- Do not rely exclusively upon the safety devices built into the unit.
- Do not cut above shoulder height.
- Do not over reach. Always keep proper footing and balance. Take extra care when working on steep slopes or inclines.
- Do not make cuts with the tip of the guide bar.
- Make sure the area of operation is free from obstructions. Do not let the tip of the guide bar contact any object, such as a log, branch, the ground or other obstruction.
- Always inspect the wood before cutting. Foreign objects could damage the unit or cause serious personal injury. Never cut through nails, metal rods, railroad ties or pallets.
- Do not operate the unit with one hand! Serious injury to the operator, helpers or bystanders may result from one-handed operation. This unit is intended for two-handed use. Always grip the unit firmly with both hands when the unit is running. Hold the front handle with the left hand and the rear handle with the right hand. Firmly encircle the handles with the thumbs and fingers. Do not let go. A firm grip will help maintain control of the unit and reduce the chance of kickback.

Kickback Safety Instructions Cont'd.

- Stand slightly to the left of the unit to avoid being in the direct line of the saw chain.
- Never start the saw when the guide bar is inside an existing cut. Be extremely careful when re-entering a cut.
- Always begin a cut with the unit running at full speed. Fully squeeze the throttle control and maintain a steady cutting speed. Slower speeds increase the chance of kickback.
- Keep the saw housing pressed firmly against the wood.
- Do not cut more than one log or branch at a time.
- Do not twist the unit when removing the guide bar from a cut.
- Watch out for shifting objects (logs, branches, etc.) that might pinch or fall onto the saw chain during operation.
- Only use wedges made of wood or plastic. Do not use metal to hold a cut open.
- Follow the manufacturer's sharpening and maintenance instructions for the saw chain.
- Only use replacement bars and chains specified by the manufacturer or the equivalent. These are available from Champion or other qualified service dealer. Use of any unauthorized parts or accessories could lead to serious injury to the operator or damage to the unit and will void the warranty.
- Use devices that reduce the risks associated with kickback, such as low-kickback chains, guide bar nose guards, chain brakes and low-kickback guide bars. There are no other replacement components for achieving kickback protection in accordance with CSA Z62.3.
- A low-kickback saw chain is a chain that has met the kickback performance requirements of ANSI/OPEI B175.1-2012 when tested according to the provisions specified in ANSI/OPEI B175.1-2012. A low-kickback saw chain is a chain that is also in accordance with CSA Z62.3. Do not use a replacement saw chain unless it has met these requirements for this specific model or has been designated as a low-kickback replacement saw chain in accordance with ANSI/OPEI B175.1-2012. As saw chains are sharpened, some of the low-kickback qualities are lost and extra caution should be used.
- Do not install a bow guide on this unit. Bow guides have larger kickback zones, which increase the chance of kickback and serious injury. This increase

Kickback Safety Instructions Cont'd.

is not significantly reduced by using a low-kickback saw chain. Using a bow guide on this unit is extremely dangerous.

Other Safety Warnings

- Follow all maintenance instructions in this manual.
- All service, other than the maintenance procedures described in this manual, should be performed by a Champion qualified service dealer.
- Do not use the unit if it is not working correctly, has been dropped, damaged, left outdoors or dropped into water. Have the unit serviced by a Champion qualified service dealer.
- Before inspecting, servicing, cleaning, storing, transporting or replacing any parts on the unit:
 1. Stop the unit.
 2. Make sure all moving parts have stopped.
 3. Allow the unit to cool.
 4. Disconnect the spark plug wire.
- Secure the unit while transporting.
- Always use the scabbard on the guide bar and saw chain during transportation and storage.
- Always store the unit and fuel in a cool, dry and well-ventilated space. Do not store fuel, or a unit with fuel in the tank, indoors where fumes may reach open flames (pilot lights, etc.) or sparks (switches, electrical motors, etc.).
- Store the unit in a dry place, secured or at a height to prevent unauthorized use or damage. Keep the unit out of the reach of children.
- Never douse or squirt the unit with water or any other liquid. Keep handles dry, clean and free from debris, oil, fuel and grease. Clean the unit after each use. Refer to Cleaning and Storage. Do not use solvents or strong detergents.
- **Keep these instructions.** Refer to them often and use them to instruct other users. If you loan this unit to others, also loan them these instructions.

SAVE THESE INSTRUCTIONS





WARNING











This spark ignition system complies with the Canadian standard ICES-002

SAFETY RULES









Safety and International Symbols

This operator's manual describes safety and international symbols and pictographs that may appear on this product. Read the operator's manual for complete safety, assembly, operating and maintenance and repair information.

Symbol	Meaning
	Safety Alert Symbol Indicates danger, warning or caution. May be used in conjunction with other symbols or pictographs.
	Read Operators Manual WARNING: Read the operator's manual(s) and follow all warnings and safety instructions. Failure to do so can result in serious injury to the operator and/or bystanders.
	Wear Head, Eye and Hearing Protection WARNING: Thrown objects and loud noise can cause severe eye injury and hearing loss. Wear eye protection meeting current ANSI Z87.1 standards and ear protection when operating this unit. Wear head protection when operating this unit; falling objects can cause severe head injury. Use a full face shield when needed.
	Unleaded Fuel Always use clean, fresh unleaded fuel. Safety Alert Symbol OIL: Refer to operator's manual for the proper type of oil.
	Do Not Use E85 Fuel In This Unit WARNING: It has been proven that fuel containing greater than 10% ethanol will likely damage this engine and void the warranty.

Symbol	Meaning
	On/Off Stop Control On / Start / Run
	On/Off Stop Control Off or Stop
	Primer Bulb Push Primer Bulb, fully and slowly, 4 times.
	Choke Control Pulled Out - FULL choke position. Pushed In - RUN position.
	Keep Bystanders Away WARNING: Keep all bystanders, especially children and pets, at least 50 feet (15 m) from the operating area.
	Use Both Hands WARNING: Always use both hands while operating the unit. Never use only one hand to operate the unit.
	Kickback WARNING: Contact of the guide bar tip with any object should be avoided. Tip contact may cause the guide bar to move suddenly upward and backward, which may cause serious injury.
	Chain and Oil Adjustment Indicator The chain must be continuously coated with oil to function properly. Make sure to set the oil adjustment screw to allow a sufficient amount of oil to flow continuously onto the chain.
	Chain Brake The chain brake immediately stops the moving saw chain in emergency situations. To manually engage the chain brake, push the chain brake lever forward completely. To disengage the chain brake, pull the chain brake lever back completely.
	Chain Direction Make sure the saw chain faces the direction shown when installed on the guide bar. Refer to Installing the Guide Bar and Saw Chain in the Maintenance section.
	Chain Tensioning Always keep the saw chain properly tensioned. Turn the chain-tensioning screw clockwise to tighten the saw chain. Turn the chain-tensioning screw counterclockwise to loosen the saw chain.

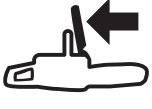
Starting Instructions Symbols

Symbol	Meaning
	1. Engage Engage the chain brake.
	2. Prime Slowly press and release the Primer Bulb 4 times.
	3. On/Off Move On/Off switch to On position
	4. Choke Pull Choke Knob out.
	5. Start Set the unit on a flat surface and hold securely; pull Recoil Start rope. When engine starts, allow the saw to warm up for 30-60 seconds before cutting logs. If engine does not start after 4 pulls, go to step 6.
	6. Depress Depress Choke Knob.
	7. Start Pull Recoil Start rope 1-4x. When engine starts, allow the saw to warm up for 30-60 seconds before cutting logs.
	8. Disengage Disengage the Chain Brake.
	Owner's Manual Read the Owners Manual if unit does not start.



CONTROLS AND FEATURES

- | | | |
|---|-----------------------------|----------------------------|
| 1. Guide Bar | 7. Air Cleaner Cover Knob | 13. Oil Tank |
| 2. Saw Chain | 8. Choke Knob | 14. Fuel Tank |
| 3. Front Hand Guard and Chain Brake Lever | 9. Throttle Trigger Lockout | 15. Guide Bar Scabbard |
| 4. Front Handle | 10. Rear Handle | 16. Primer Bulb |
| 5. Starter Handle | 11. Throttle Trigger | 17. Clutch Cover |
| 6. Air Filter Cover | 12. Engine Switch | 18. Chain Tensioning Screw |

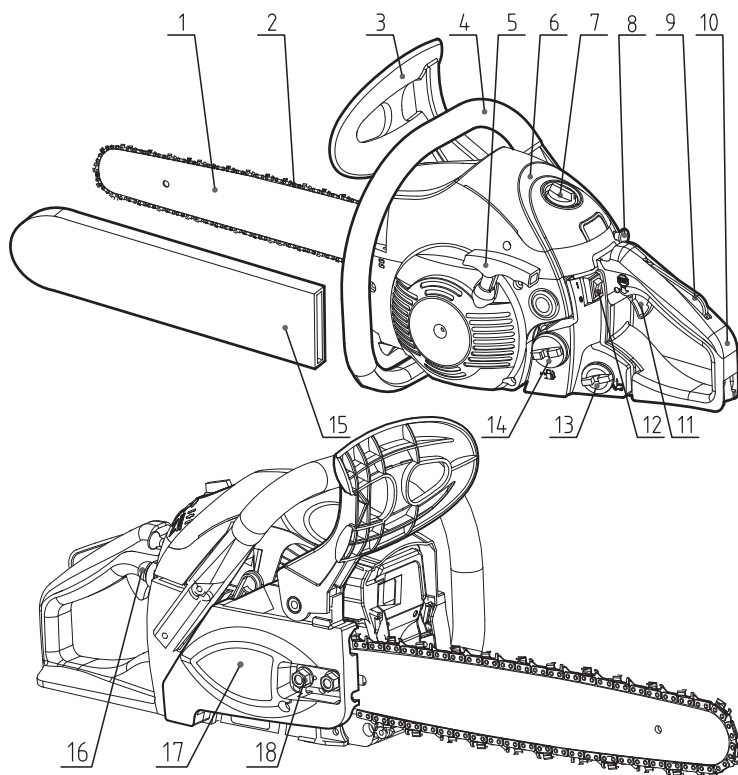

SAFETY FEATURES

- **LOW-KICKBACK SAW CHAIN** significantly reduces the chance of kickback and the intensity of kickback, due to specially designed depth gauges and guard links.
- **The SPARK ARRESTER SCREEN** retains carbon and other flammable particles over 0.023 inches (0.6mm) in size from the engine exhaust flow. Compliance with local, state and federal laws and/or regulations governing the use of a spark arrester screen is the user's responsibility. Refer to Spark Arrester Note in the Safety section for additional information.
- **CHAIN BRAKE LEVER / FRONT HAND GUARD** helps protect the operator's left hand if it slips off the front handle while the unit is running. The chain brake lever is also used to manually engage the chain brake.
- **CHAIN BRAKE** reduces the chance of injury if kickback occurs, by stopping the saw chain in milliseconds. The chain brake is designed to engage automatically in response to kickback. The chain brake can also be activated by pushing the chain brake lever forward, either intentionally or if the operator's hand strikes the lever during kickback.
- **ON/OFF SWITCH** immediately stops the engine when moved to the OFF position. The On/Off switch must be moved to the On position to start the engine.
- **THROTTLE LOCKOUT** prevents accidental acceleration of the engine. The throttle control cannot be squeezed unless the throttle lockout is depressed.
- **CHAIN CATCHER** reduces the chance of injury if the saw chain breaks or derails during operation. The chain catcher is designed to intercept a whipping chain.

Adding Bar and Chain Oil: Initial Use

This unit comes from the factory with the chain oil reservoir empty. Refer to Adding Bar and Chain Oil instructions in the Maintenance section.

Adjusting the Chain Tension: Initial Use

The saw chain must be properly tensioned before attempting to start or operate the unit. The saw chain may also require additional tensioning as the saw chain heats up during operation. Refer to Adjusting the Chain Tension instructions in the Maintenance section.

Testing the Chain Brake

⚠ WARNING

Always activate the chain brake slowly and deliberately. Keep the saw chain from touching anything. Do not let the chain saw tip forward.

Always test the chain brake before using the unit.

1. Set the unit on a flat, level surface.
2. Make sure the chain brake lever is pulled back in the disengaged position (Fig. 1).
3. Start the unit. Refer to Starting Instructions in the Starting and Stopping section. Maintain a proper grip. Refer to Holding the Unit in the Operation section.
4. While the unit is running, squeeze the throttle control to 1/3 throttle and then engage the chain brake by pushing the chain brake lever forward with the left hand (Fig. 1). The chain should stop moving abruptly. **IF...If the chain stops moving, the chain brake is working correctly.**
IF...If the chain does not stop moving, have the unit serviced by Champion or other qualified service dealer.
5. Stop the engine and return the chain brake to the disengaged position. Refer to *Stopping Instructions* in the *Starting and Stopping* Section.

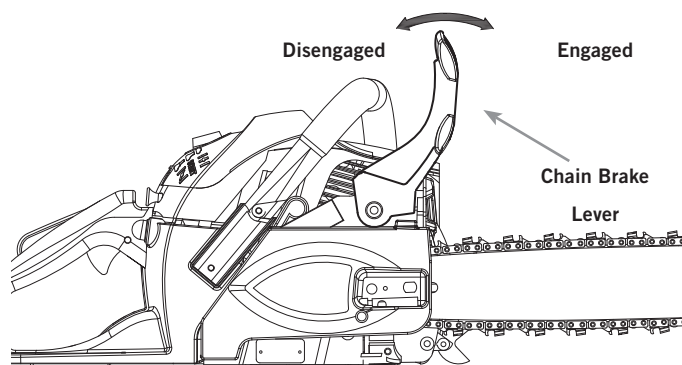

Fig. 1

Oil and Fuel Mixing Instructions

The use of old and/or improperly mixed fuel is the most common cause of performance problems. Use only fresh, clean unleaded gasoline. Follow the instructions carefully for the proper gasoline/oil mixture.

Definition of Blended Fuels

Today's fuels are often a blend of gasoline and oxygenates such as ethanol, methanol or MTBE (ether). Alcohol-blended fuel absorbs water. As little as 1% water in the fuel can make fuel and oil separate, forming acids when stored. ALWAYS use fresh fuel (less than 30 days old).

⚠ NOTICE

Dispose of old fuel according to federal, state and local regulations.

Using Blended Fuels

If using a blended fuel:

- Always use the fresh fuel mix explained in your operator's manual
- Use the fuel additive STA-BIL® or an equivalent
- Always agitate the fuel mix before fueling the unit
- Drain the tank and run the engine dry before storing the unit

⚠ WARNING

Do Not Use E85 Fuel In This Unit

It has been proven that fuel containing greater than 10% ethanol will likely damage this engine and void the warranty.

Using Fuel Additives

Always use a 2-cycle oil designed for air-cooled engines and mix it with a fuel additive, such as STA-BIL Fuel Stabilizer or an equivalent. Add 0.8 oz. (23mL) of fuel additive per gallon of fuel, according to the instructions on the container. NEVER add fuel additives directly to the unit's fuel tank.

ASSEMBLY

Mixing the Fuel



⚠ WARNING

When fueling or using your chainsaw, a fire extinguisher should be available.

⚠ CAUTION

For proper engine operation and maximum reliability, pay strict attention to the gasoline and oil mixing instructions on the 2-cycle oil bottle. Using improperly mixed fuel can severely damage the engine.

Thoroughly mix the proper ratio of unleaded gasoline with 2-cycle engine oil. Do not mix them directly in the unit's fuel tank. Use a separate fuel can. Use a 40:1 gasoline/oil ratio. See the table below for specific gasoline and oil mixing ratios.

	
Unleaded gasoline	2-cycle oil
1 gallon U.S. (3.8 L)	3.2 fl. oz. (95 mL)
1 L	25 mL

MIXING RATIO - 40:1

⚠ WARNING

Gasoline is extremely flammable. Ignited vapors may explode. Always stop the engine and allow it to cool before filling the fuel tank. Do not smoke while filling the tank. Keep sparks and open flames at a distance from the area.

⚠ WARNING

Remove the fuel cap slowly to avoid injury from fuel spray. Never operate the unit without the fuel cap securely in place.

Mixing the Fuel Cont'd

⚠ WARNING

Add fuel in a clean, well ventilated outdoor area. Wipe up any spilled fuel immediately. Avoid creating a source of ignition for spilled fuel. Do not start the engine until fuel vapors dissipate.

1. Position the unit with the fuel cap facing up.
2. Remove the fuel cap (Fig. 2).

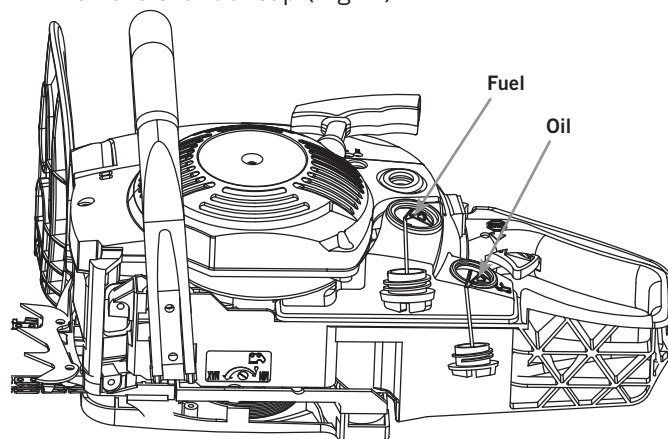

Fig. 2

⚠ NOTICE

Do NOT overfill the tank

3. Place the fuel container spout into the fill hole on the fuel tank and fill the tank.
4. Wipe up any fuel that may have spilled.
5. Reinstall the fuel cap.
6. Move the unit at least 30 ft. (9.1 m) from the fuel container and the fueling site before starting the engine.

Starting and Stopping

⚠ WARNING

When fueling or using your chainsaw, a fire extinguisher should be available.

⚠ WARNING

Operate this unit only in a well-ventilated outdoor area. Carbon monoxide exhaust fumes can be lethal in a confined area.

⚠ WARNING

Avoid accidentally starting the unit. To avoid serious injury, the operator and the unit must be in a stable position when pulling the starter rope (Fig. 5).

⚠ WARNING

Never operate the unit without the guide bar and saw chain properly installed. Make sure the bar-retaining nuts are tight and the guide bar cover is securely assembled. Make sure the saw chain is properly tensioned.

⚠ WARNING

The saw chain will spin after the engine starts. Keep hands and feet clear of the saw chain and do not allow the saw chain to contact any object(s).

Starting Instructions

1. Mix gasoline with oil. Refer to Oil and Fuel Mixing Instructions.
2. Fill the fuel tank. Refer to Fueling the Unit.
3. Fill the chain oil reservoir with bar and chain oil. Refer to Adding Bar and Chain Oil in the Maintenance section.
4. Make sure the chain brake is engaged. Refer to Testing the Chain Brake in the Assembly section.
5. Move the On/Off switch to the On position (Fig. 3).
6. Slowly press and release the primer bulb 4 times (Fig. 4). If fuel cannot be seen in the primer bulb, press and release the primer bulb until fuel is visible.
7. Pull the choke knob out to Position 1 (Fig. 4).

Starting and Stopping Cont'd

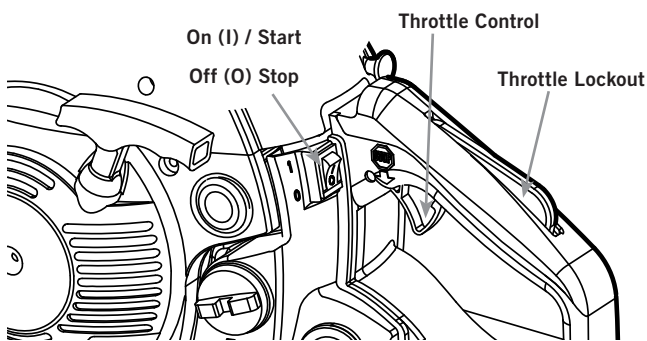

Fig. 3

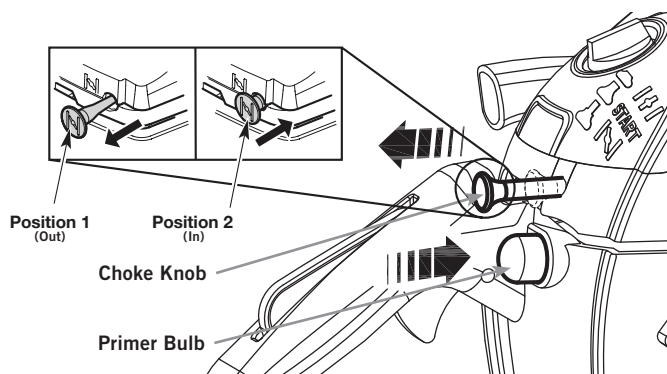

Fig. 4

8. DO NOT touch the throttle control (Fig. 3). Set the unit on a flat, level surface. Clear the area of any objects that could contact the saw chain.

🗨 NOTICE

DO NOT touch the throttle control until step 14 (Fig. 3)

9. DO NOT touch the throttle control. Crouch in the starting position (Fig. 5). Hold the front handle with the left hand. Hold the starter rope grip with the right hand. Insert the right foot into the boot loop to help hold the unit firmly in place.

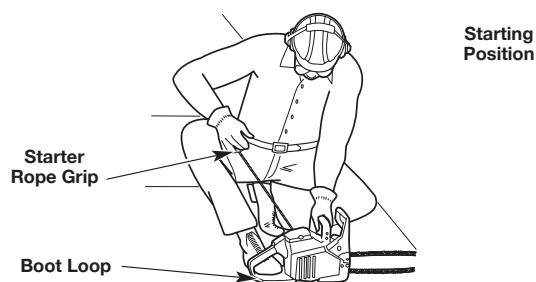

Fig. 5

10. DO NOT touch the throttle control. Pull the starter rope with a controlled and steady motion up to 4 times or until engine starts (Fig. 5).
11. If unit does not start, DO NOT touch the throttle control. Push the choke knob in to Position 2 (Fig. 4).

OPERATION

Starting Instructions Cont'd

12. DO NOT touch the throttle control. Pull the starter rope with a controlled and steady motion 3 to 5 times to start the engine.
13. When engine starts, make sure choke knob is pushed in (position 2). DO NOT touch the throttle control. Allow the engine to warm up for 30 to 60 seconds.
14. Press and hold the throttle lockout. Lightly squeeze and release the throttle control to idle the engine.

WARNING

The saw chain should not move when the engine runs at idle. If it does move, refer to Adjusting the Idle Speed in the Maintenance section.

15. To reduce the chance of injury, engage the chain brake until you are ready to begin operation. When ready, disengage the chain brake. Then press the throttle lockout and squeeze the throttle control to accelerate the engine, as needed.

NOTICE

The engine is properly warmed up when it accelerates without hesitation.

IF...the engine hesitates, continue the warm-up.

IF...the engine does not start, begin the starting procedure with step 4.

IF...the engine fails to start after a few attempts, pull the choke knob out to **Position 1** and then push the choke knob back in to **Position 2**, so that the throttle will be set in a partially open position. Pull the starter rope with a controlled and steady motion **3 to 8 times**. The engine should start. If it does not, repeat this instruction.

IF...the engine is already warm, make sure the On/Off switch is in the **On** position, crouch in the starting position, pull the choke knob out to **Position 1** and then push the choke knob back in to **Position 2**. Begin the starting procedure with step 12.

WARNING

When carrying a chainsaw with engine running, always engage the chain brake.

Stopping Instructions

1. Release the throttle control and allow the engine to idle.
2. Move the On/Off switch to the Off position (Fig. 3). Wait for the saw chain to come to a complete stop.

Emergency Stopping

1. Push the chain brake lever forward to engage the chain brake. Refer to Testing the Chain Brake in the Assembly section.
2. Move the On/Off switch to the Off position

WARNING

Always check the chain tension and adjust as necessary before beginning operation. Refer to Adjusting the Chain Tension in the Maintenance section.

WARNING

Make sure the chain oil reservoir is full before operation. Check the oil level periodically so that it does not drop below half full. Make sure the chain oil adjustment screw is set appropriately. Refer to Setting the Chain Oil Adjustment Screw in the Maintenance section. The saw chain must be continuously coated with oil to function properly.

WARNING

Always wear appropriate eye, hearing, hand, foot and body protection to reduce the risk of injury when operating this unit. Wear head protection. Use a full face shield when needed. Refer to the Safety section for appropriate safety equipment information.

Tips for Best Results

- Follow all safety instructions. Refer to the Safety section.
- Only cut wood and materials made of wood. Do not attempt to cut sheet metal, plastics, masonry or any other non-wood materials.
- Practice cutting a few small logs before beginning a major cutting operation.
- Do not attempt to cut trees or logs with diameters larger than 17 in. (43.2 cm).

Preparing the Work Area

WARNING

When fueling or using your chainsaw, a fire extinguisher should be available.

- Clear the area of children, bystanders and pets; keep them outside a 50-foot (15 m) radius, at a minimum. Even then, they are still at risk from thrown objects. Encourage bystanders to wear eye protection. If you are approached, stop the unit immediately. When felling, the safe distance is at least twice the height of the tallest tree in the work area. When bucking, keep workers at least 15 feet (4.6 m) apart.
- Keep the work area clean. Cluttered areas invite injuries. Do not start cutting until the work area is clear and free from obstructions. Make sure there is secure footing and a planned retreat path from falling trees or branches.
- Do not cut near electrical cables or power lines. Keep at least 50 feet (15 m) away from all power lines.
- Use the unit only in daylight or good artificial light.

Holding the Unit

WARNING

When carrying a chainsaw with engine running, always engage the chain brake.

WARNING

Always hold the front handle with the left hand and the rear handle with the right hand. Always keep all body parts to the left of the chain line.

- Firmly encircle the handles with the thumbs and fingers (Fig. 6). This will help reduce the chance of losing control of the unit if kickback occurs. Any grip with thumbs and fingers on the same side of the handles is dangerous.
- Always grip the unit firmly with both hands when the unit is running.
- Hold the front handle with the left hand. Keep the left arm straight to help withstand potential kickback.
- Hold the rear handle with the right hand. Keep the right arm slightly bent.
- Use these hand placements whether the operator is left-handed or right-handed. This will help keep the

Holding the Unit Cont'd

operator slightly to the left of the unit and out of the direct line of the chain saw if kickback occurs (Fig. 7 and Fig. 8).

- Stand in a stable position with feet apart and firmly planted.
- Do not cut above shoulder height. Do not over reach.

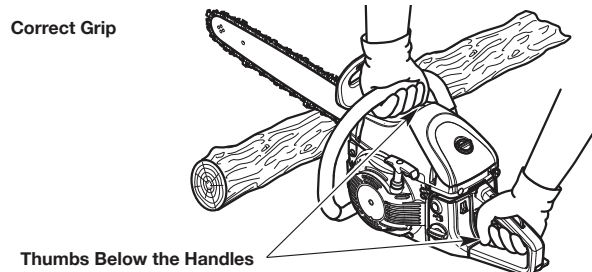

Fig. 6

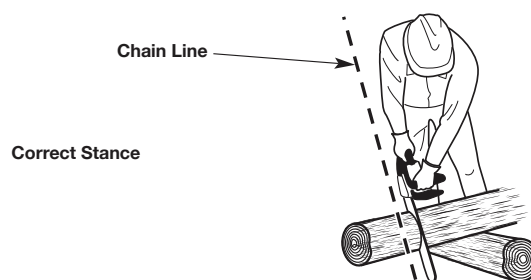

Fig. 7

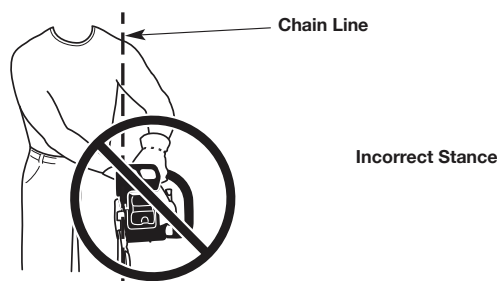

Fig. 8

Cutting Procedure Basics

1. Start the unit. Refer to Starting Instructions in the Starting and Stopping section.
2. Keep your fingers off the throttle control until you are ready to make a cut.
3. Accelerate the unit to full speed before cutting.
4. Press the unit against the wood and maintain a firm, steady pressure through most of the cut. Do not put pressure on the unit at the end of the cut.
5. Maintain a steady speed throughout the cut. Keep the unit running through the entire cut.
6. Do not try to force the saw through the wood. Allow the saw chain to do the cutting. Exert only light pressure. Forcing the cut could result in damage to the unit or personal injury.

OPERATION

Cutting Procedure Basics Cont'd

7. Release the throttle control as soon as the cut is completed. Allow the saw chain to come to a complete stop. The saw chain, guide bar and engine may experience unnecessary wear if the unit is run without a cutting load.

Felling: Safety

Felling is the process of cutting down a tree. Follow these safety precautions to reduce the risk of serious injury, property damage and damage to electrical lines:

- Do not fell trees with an extreme lean. Do not fell trees with rotten limbs, loose bark or hollow trunks. Have these trees pushed or dragged down with heavy equipment.
- Do not cut trees near buildings or electrical lines. Leave these operations for professionals. If a felled tree does contact an electrical line, notify the utility company immediately.
- Check the tree for damaged or dead branches that could fall and cause serious injury.
- Remove dirt, stones, loose bark, nails, wire and other obstructions from the portion of the tree that will be cut.
- When bucking and felling operations are performed by two or more persons in the same general area, they should be separated from each other by a distance of at least twice the height of the tree to be felled.
- Consider the force and direction of the wind. Consider the lean and balance of the tree. Consider the location of large branches. All of these factors influence the direction that the tree will fall. Do not try to fell a tree in a direction other than its natural fall line.
- Do not fell trees during periods of precipitation or high winds.
- Determine a safe and expedient escape route. Clear the area around the tree and make sure there are no obstructions blocking the escape route. Establish a 90° corridor of escape, approximately 135° from the line of fall (Fig. 9).
- Stay uphill from the tree; it will most likely roll or slide after it falls.

Felling: Safety Cont'd

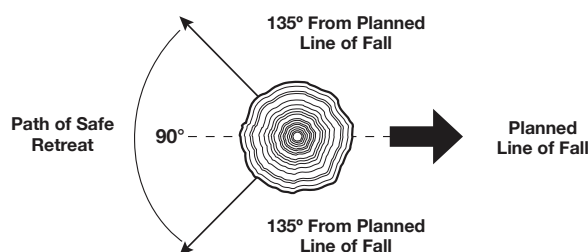

Fig. 9

Felling: Procedure

Small trees, up to 6 - 7 inches (15 - 18 cm) in diameter, are usually felled in a single cut. Larger trees require a sequence of two cutting operations: a notched undercut followed by a felling back cut. It may also be necessary to remove buttress roots.

Step 1: Removing Buttress Roots

Buttress roots are large roots that extend above the ground and help support the tree. If the tree has large buttress roots that might impede the felling process, follow these steps to remove them:

1. Make a horizontal cut into the buttress root (Fig. 10). To prevent the guide bar from being pinched by the weight of the wood, always make this cut first.
2. Make a vertical cut into the buttress root (Fig. 10).
3. Remove the loose section from the work area.

Step 2: Making the Notched Undercut

WARNING

Never walk in front of a tree with a notched undercut.

This cut determines which direction the tree will fall. Always make this cut on the side of the tree facing the direction where the tree should fall. Make the cut at 90° to the line of fall.

1. Make a horizontal cut into the trunk of the tree (Fig. 11). The cut should be about 1/3 the diameter of the tree and close to the ground. To prevent the guide bar from being pinched by the weight of the wood, always make this cut first.
2. Make a 45° cut into the trunk of the tree, above the first cut (Fig. 11). Continue cutting until the two cuts meet.
3. Remove the loose section from the work area.

Step 2: Making the Notched Undercut Cont'd

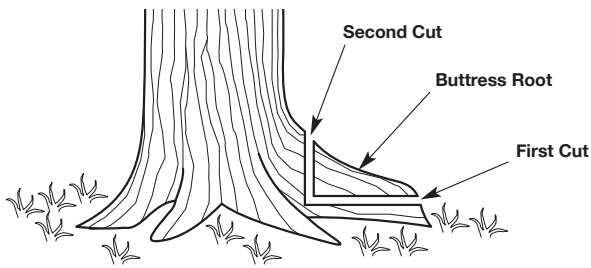

Fig. 10

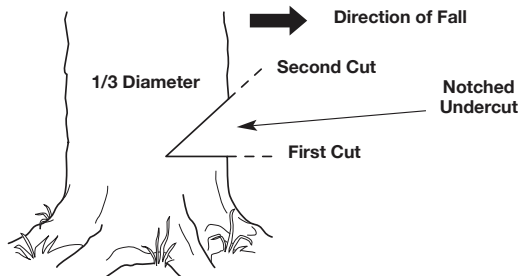

Fig. 11

Step 3: Making the Felling Back Cut

⚠ WARNING

Always recheck the area for bystanders, animals and obstacles before making the felling back cut.

This cut fells the tree.

1. Make a horizontal cut into the opposite side of the tree from the notched undercut (Fig. 12). Make the cut approximately 2 inches (5 cm) above the bottom of the notched undercut (Fig. 12).
2. As the cut gets close to the notched undercut, only a thin band of wood will support the tree. This band of wood is referred to as the hinge (Fig. 12). The hinge helps control the fall of the tree. Leave approximately 2 inches (5 cm) of hinge in place. Do not cut through the hinge. Cutting through the hinge could cause the tree to fall in any direction.

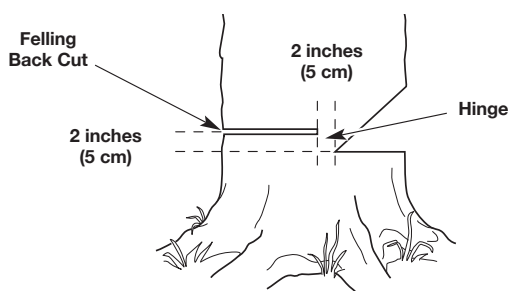

Fig. 12

3. Periodically glance up during the felling back cut to see if the tree is going to fall in the correct direction. If there is a chance that the tree might not fall in the desired direction, or if the tree might

Step 3: Making the Felling Back Cut Cont'd

rock back and bind the chain saw, remove the guide bar from the cut, stop the unit and use wedges to open the cut and direct the fall (Fig. 13). Only use soft plastic or wooden wedges. Drive the wedges into the cut slowly. Once the wedges are in place and the cut is held open, either carefully reinsert the guide bar and continue the cut or slowly drive the wedges in further to push the tree over.



Fig. 13

4. As the hinge gets smaller, the tree should begin to fall. When the tree begins to fall, remove the chain saw from the cut, stop the engine and set the unit down immediately. Promptly exit the area along the retreat path, but keep watching the tree as it falls.

⚡ DANGER

If the tree starts to fall in the wrong direction and binds the chain saw, leave the unit and evacuate the area immediately! Do not try to save the chain saw!

⚠ WARNING

Stay clear of spring poles when operating the unit. Spring poles are branches, logs, roots or saplings that are bent under tension by other wood (Fig. 14). When the tension is released, spring poles can strike the operator, causing serious injury and potentially knocking the chain saw into the operator's body. Use extreme caution when cutting spring poles or when releasing the cause of tension.

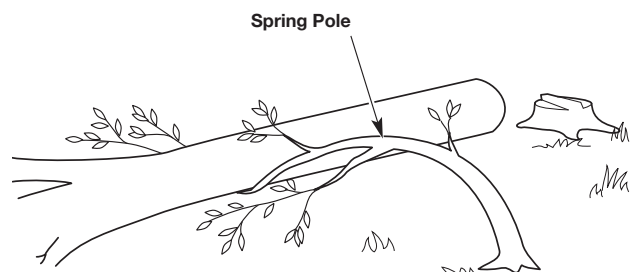

Fig. 14

OPERATION

Limbing

Limbing is the process of removing branches from a fallen tree.

1. Leave the larger support limbs under the tree for last (Fig. 15). These will keep the tree off the ground during the limbing process.
2. Cut one limb at a time. Stand on the opposite side of the tree from the limb (Fig. 15). Keep the trunk between the operator and the chain saw. To avoid binding the chain saw, branches under tension should be cut from the bottom up.
3. Remove the cut limbs from the work area.

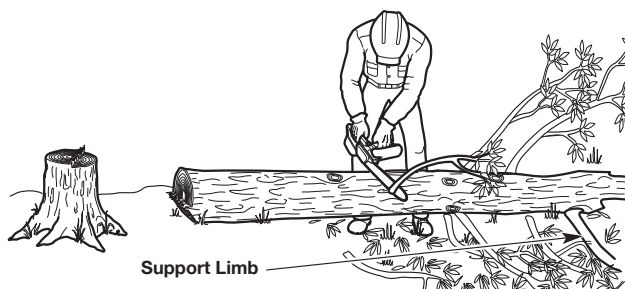

Fig. 15

Bucking: Safety

Bucking is the process of cutting a fallen tree into logs of desired lengths. Follow these safety precautions to reduce the risk of serious injury:

1. Clear the area of objects or obstructions that could contact the guide bar and result in kickback.
2. When bucking on a slope, always stand on the uphill side of the fallen tree.
3. If possible, the end of the tree to be cut should be raised off of the ground. A saw horse is ideal for this purpose. If a saw horse is not available, use other logs or any remaining limb stumps. Make sure the tree is firmly supported.
4. Do not let the saw chain contact the ground or saw horse.
5. Cut one log at a time. Release the throttle control and allow the saw chain to come to a complete stop before moving on to the next log.
6. Keep feet and all other body parts clear of falling logs.

Bucking: Safety Cont'd

DANGER

Use extreme caution when cutting a fallen tree that is still attached to the root structure. When the trunk is separated from the roots, the stump has a high potential for rocking back into the hole created by the roots. This can result in serious injury or death. Never stand in the hole left by the roots. Never allow others to stand near the root structure.

Bucking: Procedure

Cutting Logs Under Stress

When logs are supported on one or both ends, the wood tends to bend during the cutting process. This can cause the chain saw to become pinched between the two sides. Pay extra attention.

1. Make the first cut approximately 1/3 the diameter of the log. Do not cut deeper than 1/3.
 - a. If the log is supported on one end (Fig. 16), make the first cut from below (underbucking). Refer to Underbucking.
 - b. If the log is supported on two ends (Fig. 17), make the first cut from above (overbucking). Refer to Overbucking.
2. Make the second cut from the opposite side until the two cuts meet. If the diameter of the wood is large enough, insert soft plastic or wooden wedges to hold the cut open and prevent pinching (Fig. 20). Take care not to touch the wedges with the saw chain.

Cutting Fully-Supported Logs

When logs are supported along the entire length, extra care should be taken to make sure the saw chain does not contact the ground or other support structure (Fig. 18).

1. Cut through the log as much as possible, without cutting into the ground or support structure. Cut from above (overbucking). Refer to Overbucking.
2. Roll the log over and finish cutting through the log from above (overbucking).

Overbucking

1. Begin cutting from above, with the bottom of the saw chain against the top of the log (Fig. 18).
2. Exert light, downward pressure. The saw will tend to pull away from the operator. Be prepared and hold the saw firmly to maintain control.

Underbucking

1. Begin cutting from below, with the top of the saw chain against the bottom of the log (Fig. 19).
2. Exert light, upward pressure. The saw will tend to push toward the operator. Be prepared and hold the saw firmly to maintain control.

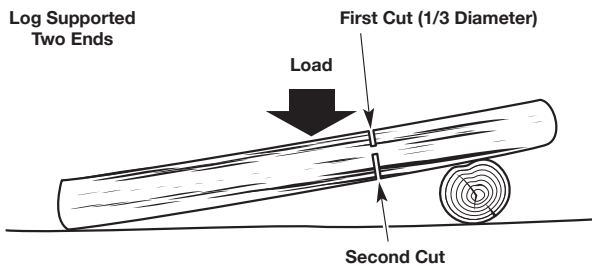
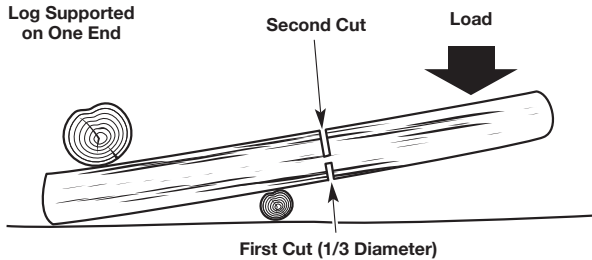

Overbucking



Underbucking

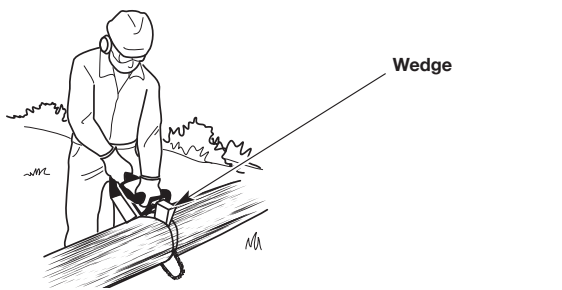
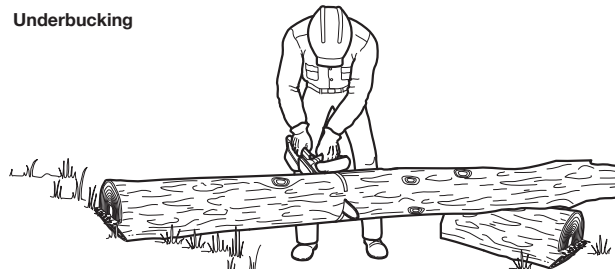

Pruning

⚠ WARNING

When carrying a chainsaw with engine running, always engage the chain brake.

⚠ WARNING

Do not cut above shoulder height. Use a pole saw to cut limbs above shoulder height or hire a professional. Do not operate the unit in a tree or on a ladder unless specifically trained to do so.

⚠ WARNING

Falling branches can cause serious injury. Always wear appropriate head protection. Plan an escape route away from falling limbs. Do not position any body parts directly below the limb when cutting.

Pruning is the process of cutting limbs from a living tree.

1. Make the first cut approximately 6 inches (15 cm) from the tree trunk. Cut upward, from the underside of the limb. Use the top of the guide bar to make this cut. Cut a third of the way through the diameter of the limb (Fig. 21).
2. Make the second cut 2 - 4 inches (5 - 10 cm) farther out on the limb. Cut downward, from the top of the limb. Use the bottom of the guide bar to make this cut. Cut completely through the limb (Fig. 21).
3. Make the third cut as close to the tree trunk as possible. Cut upward, from the underside of the limb stub. Use the top of the guide bar to make this cut. Cut a third of the way through the diameter of the limb (Fig. 21).
4. Make the fourth cut directly above the third cut. Cut downward, from the top of the limb stub. Use the bottom of the guide bar to make this cut. Cut completely through the limb stub to meet the third cut (Fig. 21). This will remove the limb stub.

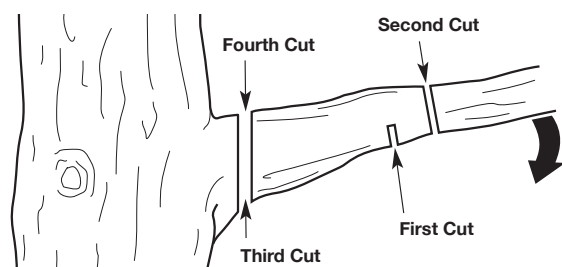

MAINTENANCE AND STORAGE

⚠ WARNING

To prevent serious injury, never perform maintenance or repairs while the unit is running. Always allow the unit to cool before servicing or repairing the unit. Disconnect the spark plug wire to prevent the unit from starting accidentally.

Maintenance Schedule

Perform these required maintenance procedures at the frequency stated in the table. These procedures should also be a part of any seasonal tune-up. All service, other than the maintenance procedures described in this manual, should be performed by Champion or other qualified service dealer.

⚠ WARNING

When fueling or using your chainsaw, a fire extinguisher should be available.

🗨 NOTICE

Some maintenance procedures may require special tools or skills. If you are unsure about these procedures, take the unit to Champion or other qualified service dealer. Call 1-877-338-0999 for more information.

🗨 NOTICE

Maintenance, replacement, or repair of the emission control devices and system may be performed by a Champion or other qualified service dealer. Call 1-877-338-0999 for more information.

🗨 NOTICE

Please read the California/EPA statement that came with the unit for a complete listing of terms and coverage for the emissions control devices, such as the spark arrestor, muffler, carburetor, etc.

Frequency	Maintenance Required
Before each use	<ul style="list-style-type: none"> – Check for loose screws, nuts or bolts (tighten as needed) – Check for damaged or worn parts* – Check the saw chain sharpness. Refer to <i>Sharpening the Saw Chain</i>. – Test the chain brake*. Refer to <i>Testing the Chain Brake</i>. – Check the chain tension (adjust as needed). Refer to <i>Adjusting the Chain Tension</i>. – Fill the chain oil reservoir (refill frequently). Refer to <i>Adding Bar and Chain Oil</i>. – Fill the fuel tank with fresh, properly mixed fuel. Refer to the <i>Oil and Fuel</i> section. – Clean the air filter. Refer to <i>Maintaining the Air Filter</i>.
After each use	<ul style="list-style-type: none"> – Clean the unit and inspect decals. Refer to Cleaning in the Cleaning and Storage section.
Every 10 hours	<ul style="list-style-type: none"> – Check the spark plug condition and gap. Refer to Maintaining the Spark Plug. – Clean the guide bar groove and oil passages. Lubricate the sprocket tip. Refer to Maintaining the Guide Bar. – Clean the cylinder fins. Refer to Cleaning in the Cleaning and Storage section.

* If maintenance or replacement is required, have the unit serviced by Champion or other qualified service dealer.

Adding Bar and Chain Oil

⚠ DANGER

Failure to fill the chain oil reservoir will cause irreparable damage to the unit and void warranty. Make sure the chain oil reservoir is always filled. Always use bar and chain oil.

⚠ WARNING

Oil constantly flows from the chain oil reservoir to oil the saw chain. Check the chain oil level frequently so that it does not drop below half full.

The guide bar and saw chain require lubrication to minimize friction. Never starve the guide bar and chain of lubricating oil. Running the unit without enough oil will decrease cutting efficiency, shorten the life of the saw chain, cause rapid dulling of the saw chain and excessive wear to the guide bar from overheating.

Adding Bar and Chain Oil Cont'd

An insufficient amount of lubricating oil is evidenced by smoke, guide bar discoloration or pitch build-up. Only use bar and chain oil that is formulated to perform over a wide range of temperatures with no diluting required in the chain oil reservoir. Do not use motor oil or any other petroleum-based oil. Do not use dirty, used or contaminated oil. Damage may occur to the guide bar or saw chain. Dispose of old oil according to federal, state and local regulations.

1. Set the unit on a flat, level surface.
2. To prevent debris from entering the chain oil reservoir, use a damp cloth to clean the chain oil reservoir cap and surrounding area.
3. Unscrew the chain oil reservoir cap (Fig. 22).
4. Carefully pour the oil into the chain oil reservoir. DO NOT overfill.
5. Reinstall the chain oil reservoir cap.
6. Wipe up any oil that may have spilled.

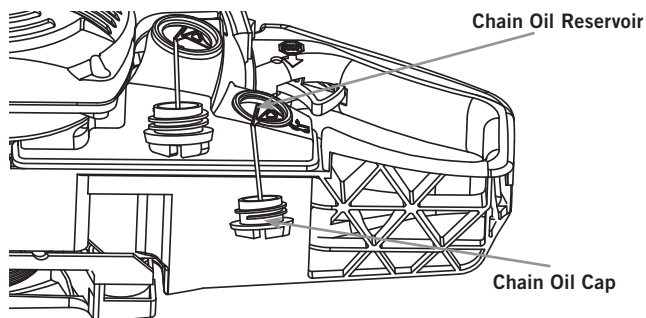

Fig. 22

Adjusting the Bar And Chain Oil Flow

Bar and chain oil will slowly flow from the chain oil reservoir onto the chain. Approximately one tank of bar and chain oil is used for every tank of fuel.

- To increase the oil flow, turn the automatic oiler adjustment screw counter clockwise with a flat-head screwdriver (Fig. 23).
- To decrease the oil flow, turn the automatic oiler adjustment screw clockwise with a flat-head screwdriver (Fig. 23).

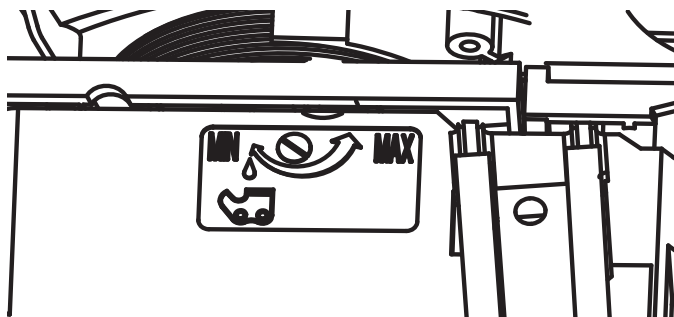

Fig. 23

Adjusting the Chain Tension

⚠ CAUTION

The guide bar, saw chain, and saw bearings will wear more rapidly if the saw chain is not properly tensioned. Maintaining proper chain tension will improve cutting performance and prolong the life of the saw chain.

⚠ WARNING

To prevent serious injury, NEVER touch the saw chain or adjust the chain tension while the unit is running. Disconnect the spark plug wire to prevent the unit from starting accidentally.

⚠ WARNING

The saw chain is very sharp. Always wear heavy-duty protective gloves when handling or performing maintenance on the saw chain.

Check the chain tension before use and visually during operation. Adjust the chain tension whenever the flats on the saw chain hang out of the bar groove (Fig. 24).

1. Make sure the chain brake is disengaged. Refer to *Testing the Chain Brake* in the Assembly section.
2. On the clutch housing, loosen (counter clockwise) the two 13mm nuts (1/4 to 1/2 turn) that secure the housing to the engine assembly. The nuts need to be loosened enough to allow the bar to move. Do not loosen the nuts more than 1 full turn. You will notice that the bar will move with minimal effort (Fig. 25).
3. On the clutch housing, immediately below the two nuts, you will find the chain tensioning screw. Insert standard screwdriver into adjustment screw head slot. While holding the bar tip up, turn clockwise to tighten chain, (counter clockwise to loosen).

The desired chain tensioning depends upon temperature of the saw chain.

- a. Cold Chain Tension - The chain should fit snugly against the underside of the guide bar. No sagging should be visible (Fig. 26).
- b. Warm Chain Tension - The steel blade expands when warm due to use. Approximately 1/16 inch (1.3 mm) of sag should be visible under the guide bar when warm (Fig. 26).

MAINTENANCE AND STORAGE

Adjusting the Chain Tension Cont'd

- Wearing protective gloves, hold the guide bar tip up and move the saw chain back and forth along the guide bar (Fig. 27). Make sure the saw chain moves freely and is in proper mesh with the sprocket. If the saw chain does not move easily, slowly turn the chain-tensioning screw counterclockwise to loosen the saw chain.

NOTICE

The saw chain will not move if the chain brake is engaged.

- Hold the guide bar tip up and securely tighten the two 13mm clutch housing nuts.

CAUTION

If the saw chain was tensioned while warm, it may become too tight when cooled. Loosen the chain tension after operation and check the chain tension before the next use.

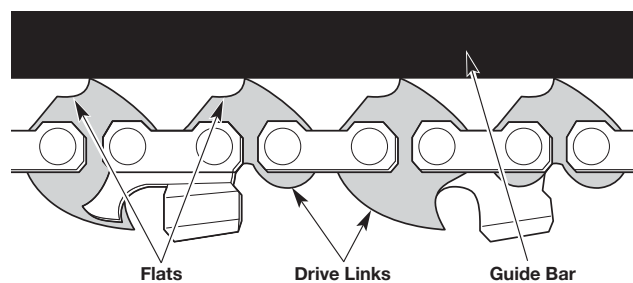

Fig. 24

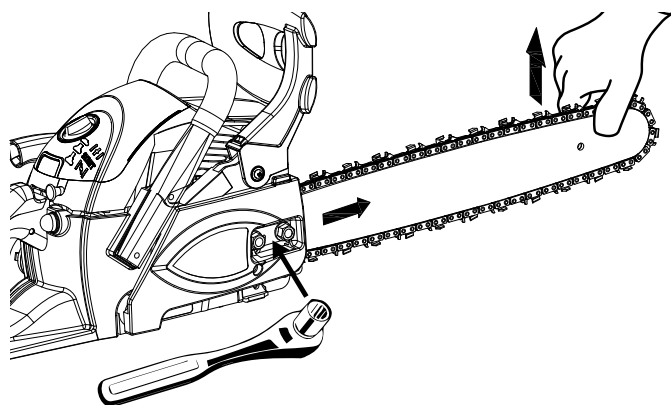

Fig. 25

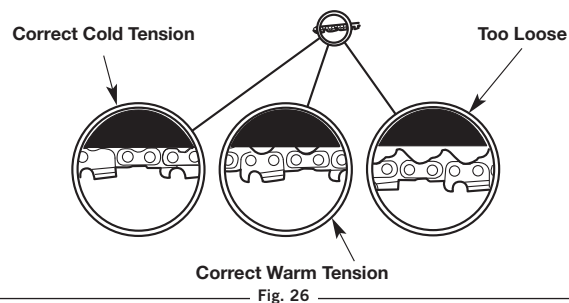

Fig. 26

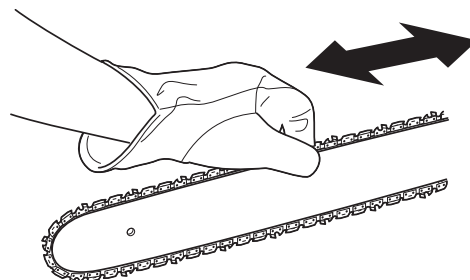

Fig. 27

IMPORTANT

It is very important to maintain the proper chain tension. Rapid wear of the guide bar or the chain coming off easily can be caused by improper tension. Especially when using a new chain, take good care of it since it should expand during first use.

Removing and Installing the Guide Bar and Saw Chain

CAUTION

The guide bar, saw chain, and saw bearings will wear more rapidly if the saw chain is not properly tensioned. Maintaining proper chain tension will improve cutting performance and prolong the life of the saw chain.

WARNING

To prevent serious injury, never touch the saw chain or adjust the chain tension while the unit is running. Disconnect the spark plug wire to prevent the unit from starting accidentally.

WARNING

The saw chain is very sharp. Always wear heavy-duty protective gloves when handling or performing maintenance on the saw chain.

Removing and Installing the Guide Bar and Saw Chain Cont'd

The guide bar and saw chain need to be removed when certain maintenance procedures are performed, such as when rotating the guide bar. When replacing old guide bars and saw chains with new parts, always use the manufacturer's specified replacement parts.

Removing the Guide Bar and Saw Chain

1. Allow the unit to fully cool after use. Place saw on flat and level surface.
2. On the clutch housing, remove (turning nuts counter clockwise) the two 13mm nuts that secures the housing to the engine assembly.
3. Wearing protective gloves, hold the guide bar tip up, grasp clutch cover and wiggle it loose (Fig. 28).

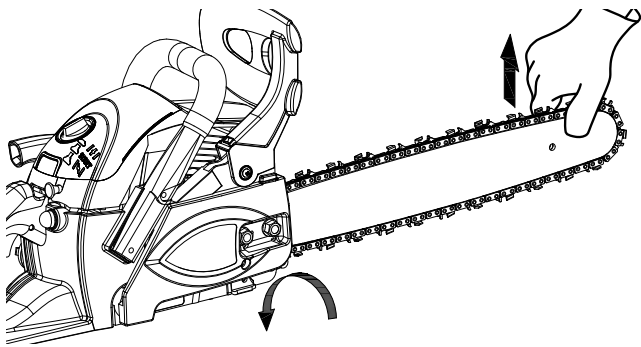

Fig. 28

4. Remove housing, review for any potential damage, clean and set aside (Fig. 29).

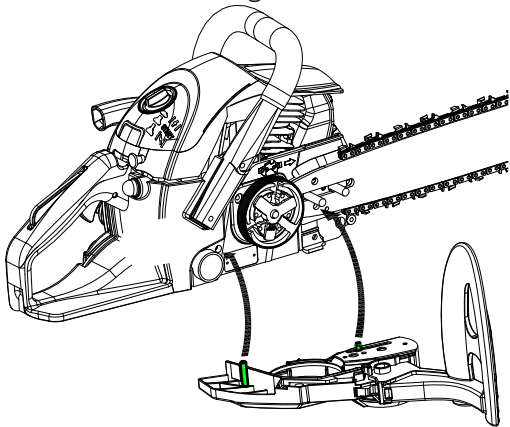

Fig. 29

5. Slide bar toward engine to loosen chain (Fig. 30).

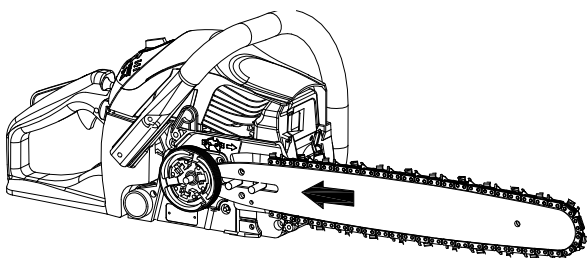

Fig. 30

Removing the Guide Bar and Saw Chain Cont'd

6. Carefully remove chain from bar, then from around gear drive clutch.
7. Remove bar from saw.
8. Clean debris, dirt, etc, from saw and bar oil ports. Inspect for damage, (replace all damaged components).

Installing the Guide Bar and Saw Chain

! CAUTION

Bar and chain are sized appropriately to each saw and gear drive for chain, **ONLY** use approved compatible components for this saw.

1. Replace new bar where text is upright. Start by inserting bar toward gear drive clutch, rotate into position with two bolt holes protruding through slot in bar.
2. Install new blade with teeth facing correct direction. Start by wrapping blade around gear driven clutch. Position blade in alignment with gear sprocket. Then wrap blade around front of bar. Being sure align blade with teeth on front of bar as well as bar groove.
3. Turn the chain tensioning screw so the post on the cover aligns with the mating hold on the guide bar.

! NOTICE

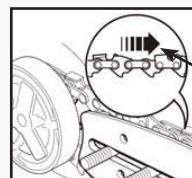

Pay attention to the correct direction of the saw chain. Moving direction.

4. Re-install the clutch cover, loosely install two 13mm nuts and turn (clockwise). Align brake onto clutch housing and two studs making sure the studs align with mating holes on clutch cover (Fig. 29).
5. Once the post on the clutch cover is properly aligned and inserted in the mating guide bar hole, tighten two 13mm nuts to hand tight.
6. While holding up the tip of the bar, tension saw chain by turning the tension screw clockwise (Right) until the tie straps just touch the bottom side of the bar rail (Fig. 31).

MAINTENANCE AND STORAGE

Installing the Guide Bar and Saw Chain Cont'd

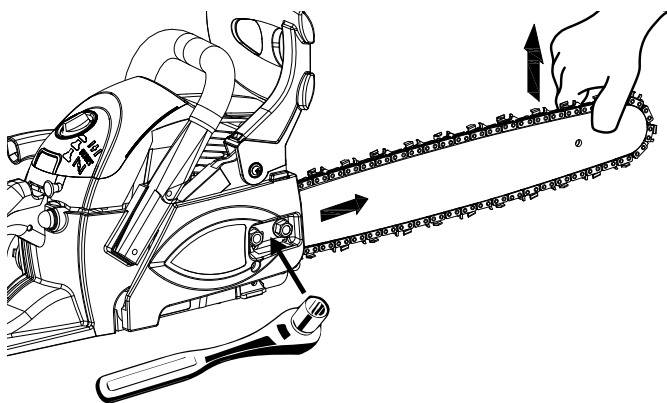

Fig. 31

- Once proper chain tension has been achieved, using a 13mm wrench or socket, fully tighten two nuts.

Maintaining the Saw Chain

For safe, efficient operation, the saw chain must be maintained properly.

The saw chain will wear with use, causing the chain to stretch. This is normal. When it is no longer possible to obtain a correct chain tension adjustment, the saw chain will need to be replaced. Refer to Replacing the Guide Bar and Saw Chain. Always keep the saw chain sharp. During operation, look for the following indicators of a dull saw chain:

- Wood chips are small and powdery.
- The saw chain must be forced through the wood.
- The saw chain cuts to one side. If any of these conditions exist, sharpen or replace the saw chain. Refer to *Sharpening the Saw Chain* or *Replacing the Guide Bar and Saw Chain*.

NOTICE

If you do not fully understand the sharpening procedure after reading the instructions, have the saw chain sharpened by Champion or other qualified service dealer or replace the saw chain.

Sharpening the Saw Chain

⚠ WARNING

The saw chain is very sharp. Always wear heavy-duty protective gloves when handling or performing maintenance on the saw chain.

⚠ WARNING

An improperly sharpened saw chain increases the chance of kickback. Failure to replace or properly maintain the saw chain can cause serious injury.

⚠ WARNING

A dull or improperly sharpened saw chain can cause excessive engine speed during operation, which can result in severe engine damage.

If the saw chain was damaged by contacting hard objects, such as nails or stones, or was abraded by mud or sand on the wood, have Champion or other qualified service dealer inspect for potential damage and sharpen or replace the blade and/or bar if needed.

When sharpening the saw chain, file all cutters to the specified angles and measurements. Other angles or measurements can cause excessive wear to the guide bar and saw chain, cause the chain to dull quickly and increase the chance of kickback. Fast cutting can be obtained only when all cutters are uniform.

- Tighten the chain tension so that the saw chain is taut and does not wobble. Refer to Adjusting the Chain Tension.
 - Always file the saw chain at the midpoint of the guide bar.
- Use a round file to sharpen the top plate and side plate of each cutter.
 - Use a 5/32 inch (4 mm) diameter file.
 - Keep the file level with the top plate of the cutter (Fig. 32). Do not let the file dip or rock. Use light, but firm pressure.
 - File toward the front corner of the cutter (Fig. 33). Lift the file away from the cutter at the end of the forward stroke. Only file on the forward stroke.
 - Apply a few firm strokes to each tooth. When filed correctly, the top plate will be at a 30° angle and the side plate will be at an 80° angle

Sharpening the Saw Chain Cont'd

(Fig. 34). Using the correct file and file holder will automatically produce the correct angles.

- e. File all the left-hand cutters in one direction (Fig. 33). Then move to the other side of the saw chain and file all of the right-hand cutters in the opposite direction (Fig. 33).
 - f. Occasionally remove filings with a wire brush.
3. Use a depth gauge tool (not included) to measure the depth gauge clearance (Fig. 35) of each cutter. The depth gauge clearance must be maintained at 1/32 inch (0.6 mm). The depth gauge clearance determines the depth at which the cutter enters the wood during operation and the size of the wood chips produced. Too much clearance increases the chance of kickback. Too little clearance decreases the size of the wood chips, thus decreasing the ability to cut.
 - a. Use a 1/32 inch (0.6 mm) depth gauge jointer and a flat file (tools not included) to lower the depth gauge to the correct clearance (Fig. 35).
 - b. After lowering the depth gauge, use the flat file to restore the original rounded shape to the depth gauge (Fig. 36). Take care not to damage the cutting edges or nearby links.

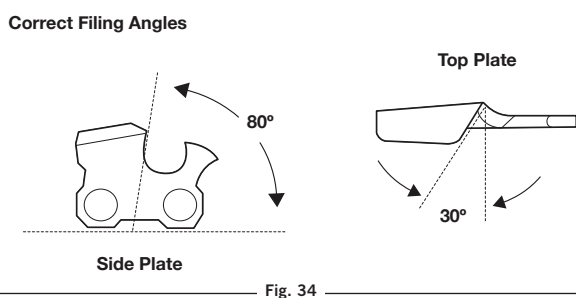
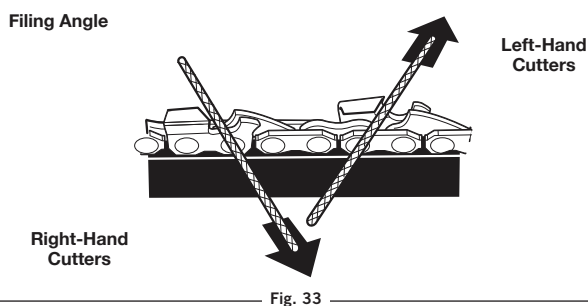
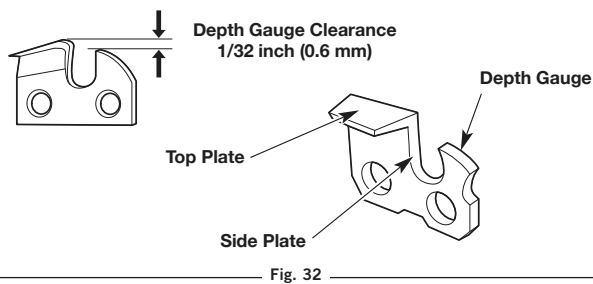

Sharpening the Saw Chain Cont'd

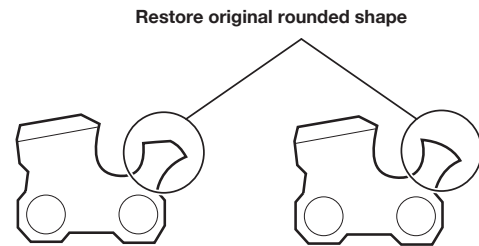
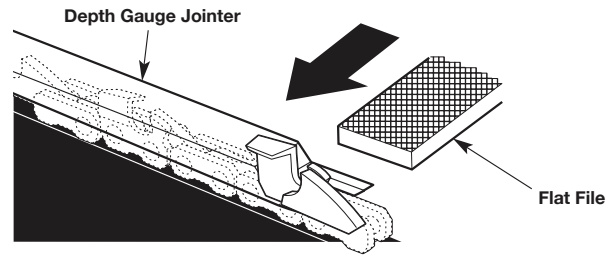

Maintaining the Guide Bar

1. Inspect the guide bar frequently, at regular intervals (for example, after every 5 hours of operation), to ensure even wear on the top and bottom of the guide bar. Refer to *Removing and Installing the Guide Bar and Saw Chain*.
2. Clean the guide bar groove and oil passages whenever the saw chain is removed, when the unit has been used heavily or when the saw chain appears dirty. Use a screwdriver, putty knife, wire brush or similar instrument to remove debris from the guide bar groove (Fig. 37). Use a small, soft wire to remove any debris from the chain oil discharge hole (Fig. 38).

NOTICE

If the oil passages are clear, the saw chain will give off a spray of oil shortly after it begins to rotate during operation.

3. Frequently check the guide bar for damage (Fig. 39). Feathering and burring of the guide bar rails (the ridges on either side of the bar groove) is a normal process of guide bar wear. Such faults should be smoothed with a file as soon as they occur (Fig. 39). A guide bar with the following faults should be replaced:
 - a. Wear inside the guide bar rails that permits the chain to lay sideways
 - b. Bent guide bar
 - c. Cracked or broken rails
 - d. Spread rails

Refer to *Replacing the Guide Bar and Saw Chain*.

MAINTENANCE AND STORAGE

Lubricating the Guide Bar Sprocket Tip

The guide bar sprocket tip was lubricated at the factory, but requires regular lubrication. Failure to lubricate the guide bar sprocket tip will result in poor performance, damage to the unit and will VOID the warranty.

NOTICE

This procedure can be performed while the guide bar and saw chain are still assembled on the unit.

1. Clean the guide bar sprocket tip thoroughly with a damp cloth (Fig. 40).
2. Use a guide bar tip lube gun (not included) to inject grease into the lubrication hole (Fig. 40). Inject grease until it appears on the outer edge of the guide bar sprocket tip.
3. Rotate the saw chain by hand. Always wear heavy-duty protective gloves. Make sure the chain brake is disengaged.
4. Repeat the lubrication process until the entire guide bar sprocket tip is lubricated.

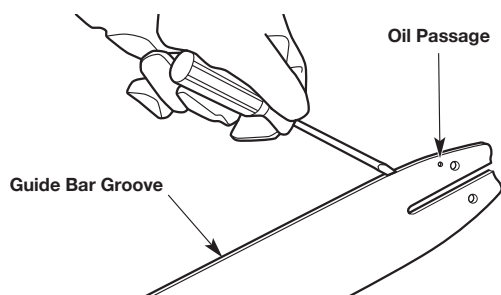

Fig. 37

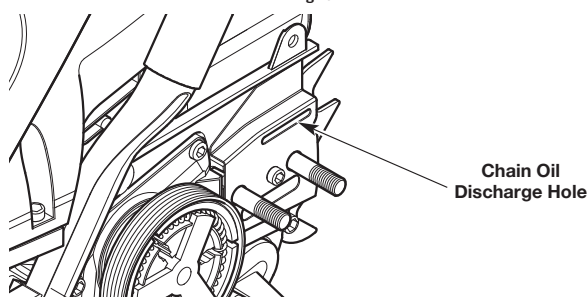

Fig. 38

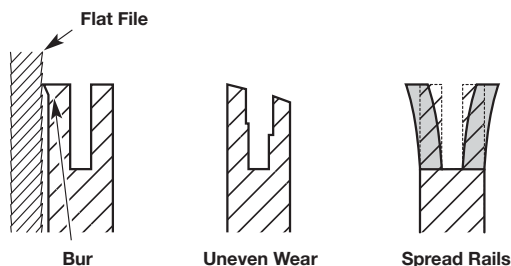

Fig. 39

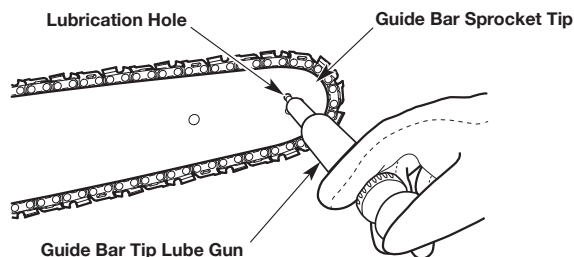

Fig. 40

Replacing the Guide Bar and Saw Chain

WARNING

Always use a low-kickback saw chain, which significantly reduces the danger of kickback. Low-kickback saw chain does not completely eliminate kickback. A low-kickback or "safety chain," should never be regarded as total protection against injury.

When replacing the guide bar and saw chain, only use the replacement parts specified by the manufacturer or their equivalents. Refer to Replacement Parts. Use of any unauthorized parts or accessories could lead to serious injury to the operator or damage to the unit and will VOID the warranty.

Always use a replacement saw chain designated as "low-kickback" or a saw chain that meets the low-kickback performance requirements. A standard saw chain (a chain that does not have the kickback-reducing guard links) should only be used by an experienced professional chain saw operator.

Maintaining the Air Filter

WARNING

To avoid serious personal injury, always stop the engine and allow it to cool before cleaning or maintaining the unit.

Failure to maintain the air filter can result in poor performance or can cause permanent damage to the engine. Engine failure due to improper air filter maintenance is not covered by the product warranty.

Cleaning the Air Filter

1. Turn the knob on the air filter cover counter-clockwise to loosen the air filter cover (Fig. 41).
2. Remove the air filter cover (Fig. 41).
3. Remove the air filter (Fig. 42).

Cleaning the Air Filter Cont'd

4. Wash the air filter in mild detergent and water. Rinse the air filter thoroughly and allow it to dry.
5. Reinstall the air filter onto the mounting post (Fig. 42). Make sure the opening in the air filter sits securely in the air intake (Fig. 42).
6. Place the air filter cover back onto the unit. Insert the tab on the air filter cover into the slot on the chain saw housing (Fig. 41).
7. Turn the knob clockwise to tighten the air filter cover securely.

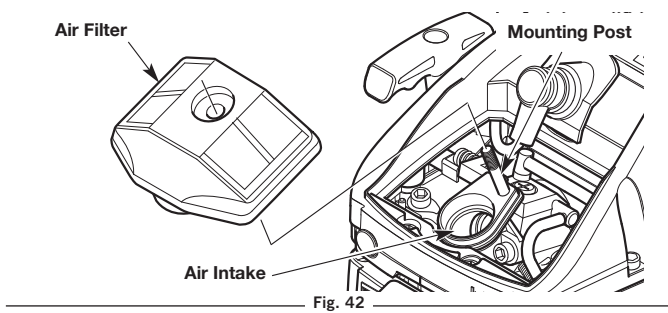
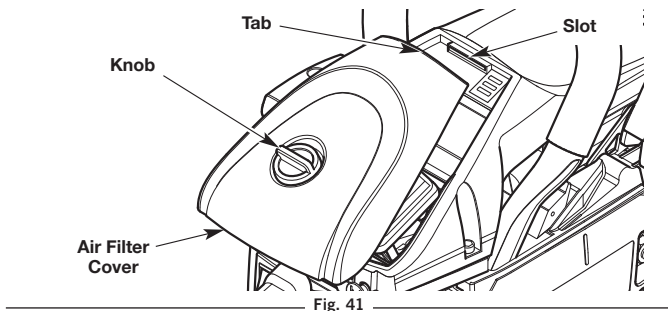

Adjusting the Idle Speed

⚠ WARNING

The saw chain may spin during idle speed adjustments. Wear protective clothing and observe all safety instructions to prevent serious personal injury.

🗨 NOTICE

Careless adjustments can seriously damage the unit. A Champion or other qualified service dealer should make carburetor adjustments.

If, after checking the fuel and cleaning the air filter, the engine still will not idle, adjust the idle speed screw as follows:

1. Start the engine. Refer to *Starting and Stopping*.
2. Release the throttle control and let the engine idle.

Adjusting the Idle Speed Cont'd

- a. If the engine stops, use a small Phillips or flat-head screwdriver to turn the idle speed screw clockwise, 1/8 of a turn at a time (as needed) until the engine idles smoothly (Fig. 43).
- b. If the engine idles too quickly, turn the idle speed screw counterclockwise, 1/8 of a turn at a time (as needed) to reduce the idle speed (Fig. 43).

🗨 NOTICE

The saw chain should not spin when the engine idles. If it does, reduce the idle speed until the saw chain stops moving.

Checking the fuel, cleaning the air filter, and adjusting the idle speed should solve most engine problems. If not, and any of the following conditions are true, take the unit to a Champion or other qualified service dealer:

- the engine will not idle
- the engine hesitates or stalls on acceleration
- there is a loss of engine power

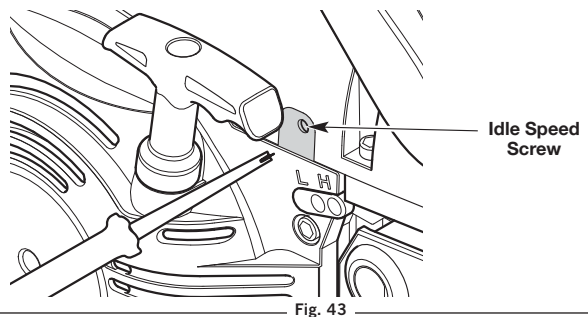

Maintaining the Spark Plug

1. Stop the engine and allow it to cool.
2. Turn the knob on the air filter cover counterclockwise to loosen the air filter cover (Fig. 41).
3. Remove the air filter cover (Fig. 41).
4. Grasp the spark plug boot firmly and pull it from the spark plug (Fig. 44).
5. Clean around the spark plug. Remove the spark plug from the cylinder head with the multi-purpose tool or a 5/8-inch socket wrench, turning counterclockwise.

⚠ WARNING

Do not sand blast, scrape or clean spark plug electrodes. Grit in the engine could damage the cylinder.

MAINTENANCE AND STORAGE

Maintaining the Spark Plug Cont'd

6. Inspect the spark plug. If the spark plug is cracked, fouled or dirty, replace it with a Champion RCJ7Y or Bosch L8RTF Spark Plug
7. Use a feeler gauge to set the air gap at 0.025 in. (0.635 mm)(Fig. 45).
8. Install the spark plug in the cylinder head. Tighten the spark plug with the multi-purpose tool or a 5/8-inch socket wrench, turning it clockwise until snug.

NOTICE

If using a torque wrench, torque to:
110-120 in.•lb. (12.3-13.5 N•m).
 Do not over tighten.

9. Reattach the spark plug boot.
10. Place the air filter cover back onto the unit. Insert the tab on the air filter cover into the slot on the chain saw housing (Fig. 41).
11. Turn the knob clockwise to tighten the air filter cover securely.

Spark Plug Boot

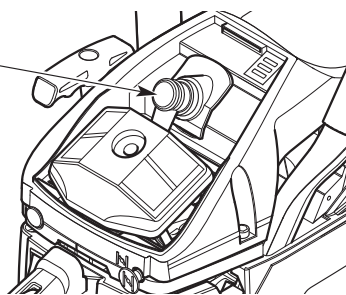

Fig. 44

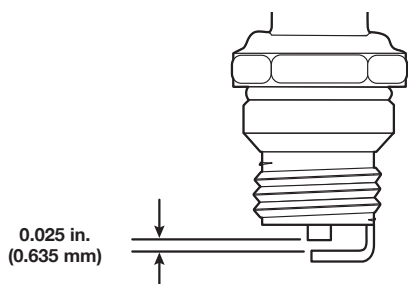

Fig. 45

Cleaning

WARNING

To avoid serious personal injury, always stop the engine and allow it to cool before cleaning or maintaining the unit.

1. Loosen the saw chain if the chain tension was adjusted during operation. The saw chain will contract as the unit cools, which could damage the unit if the chain is too tight.
2. Clean the unit with a damp cloth. Do not douse the unit with water. Do not use strong detergents. Household cleaners that contain aromatic oils such as pine and lemon, and solvents such as kerosene, can damage plastic.

NOTICE

When preparing the unit for long-term storage (30 days or more), remove the guide bar and saw chain. Carefully clean the guide bar cover, guide bar mounting surface and sprocket. Use a firm non-wire brush to clean the guide bar groove. Reassemble the unit.

3. Wipe off any moisture with a soft cloth.
4. Use compressed air, up to 40 PSI, to blow debris from the cylinder fins (Fig. 46). The cylinder fins must be cleaned on a regular basis to reduce the risk of personal injury or damage to the unit as a result of fire. Always use safety goggles/glasses when using compressed air. Do not use water or other liquids to clean the cylinder fins. Use a small wire brush to remove stubborn debris. If a significant amount of debris remains, have the unit cleaned by Champion or other qualified service dealer
5. Lightly coat the guide bar and saw chain with a corrosion-inhibiting oil.

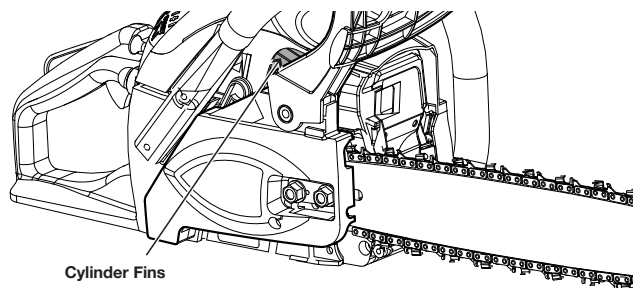

Cylinder Fins

Fig. 46

Storage

- Loosen the saw chain if the chain tension was adjusted during operation. The saw chain will contract as the unit cools, which could damage the unit if the chain is too tight.
- Allow the engine to cool before storing.
- Thoroughly clean the unit and inspect it for any loose or damaged parts. Repair or replace damaged parts and tighten loose screws, nuts or bolts.
- Cover the guide bar and saw chain with the scabbard.
- Never store a fueled unit where fumes may reach an open flame or spark.
- Lock up the unit to prevent unauthorized use or damage.
- Store the unit in a dry, well-ventilated area.
- Store the unit out of the reach of children.

NOTICE

It is normal for bar and chain oil to seep from the unit when not in use. Please take this into consideration when storing the unit.

Long-term Storage (30 days or more)

1. Remove the fuel cap, tip the unit and drain the fuel into an approved container. Reinstall the fuel cap.
2. Start the engine and allow it to run until it stalls. This ensures that all fuel has been drained from the carburetor.
3. Allow the engine to cool. Remove the spark plug and put 5 drops of any high quality motor oil or 2-cycle oil into the cylinder. Pull the starter rope slowly to distribute the oil. Reinstall the spark plug.

Preparing the Unit for Use after Long-term Storage

1. Remove the spark plug and drain all of the oil from the cylinder.

NOTICE

Do not use fuel that has been stored for more than 30 days. Dispose of old fuel according to federal, state and local regulations.

SPECIFICATIONS

Chainsaw Specifications*

- Engine Type Air-Cooled, 2-Cycle
- Displacement 40.1 cc (2.45 cu. in.)
- Spark Plug Gap 0.025 in. (0.635 mm)
- Spark Plug Champion RCJ7Y or Bosch L8RTF
- Lubrication Bar and Chain Oil
- Fuel/Oil Ratio 40:1
- Fuel Tank Capacity 13.2 oz. (390 mL)
- Chain Oil Reservoir Capacity 7.1 oz. (210 mL)
- Approximate Unit Weight (without fuel or chain oil)
 12.3 lbs. (5.6 kg)
- Guide Bar Length 18 in. (45.7 cm)
- Saw Chain Pitch 0.375 in. (9.5 mm)
- Saw Chain Gauge 0.050 in. (1.3 mm)

* All specifications are based on the latest product information available at the time of printing. We reserve the right to make changes at anytime without notice.

Replacement Parts

Please contact the Customer Support Department to order replacement parts.

Part Number	Description	Brand	Pitch	Gauge	Edge
39272	Guide Bar Chain (18 in. / 45.7 cm) / Chain Set	Oregon	3/8 in.	.050 in.	5/32 in. (4 mm)
91P062E, G, or X	Chain (18 in. / 45.7 cm)	Oregon	3/8 in.	.050 in.	5/32 in. (4 mm)
180SDEA041	Guide Bar (18 in. / 45.7 cm)	Oregon	N/A	N/A	N/A

PAGE INTENTIONALLY LEFT BLANK

SPECIFICATIONS

Parts Diagram

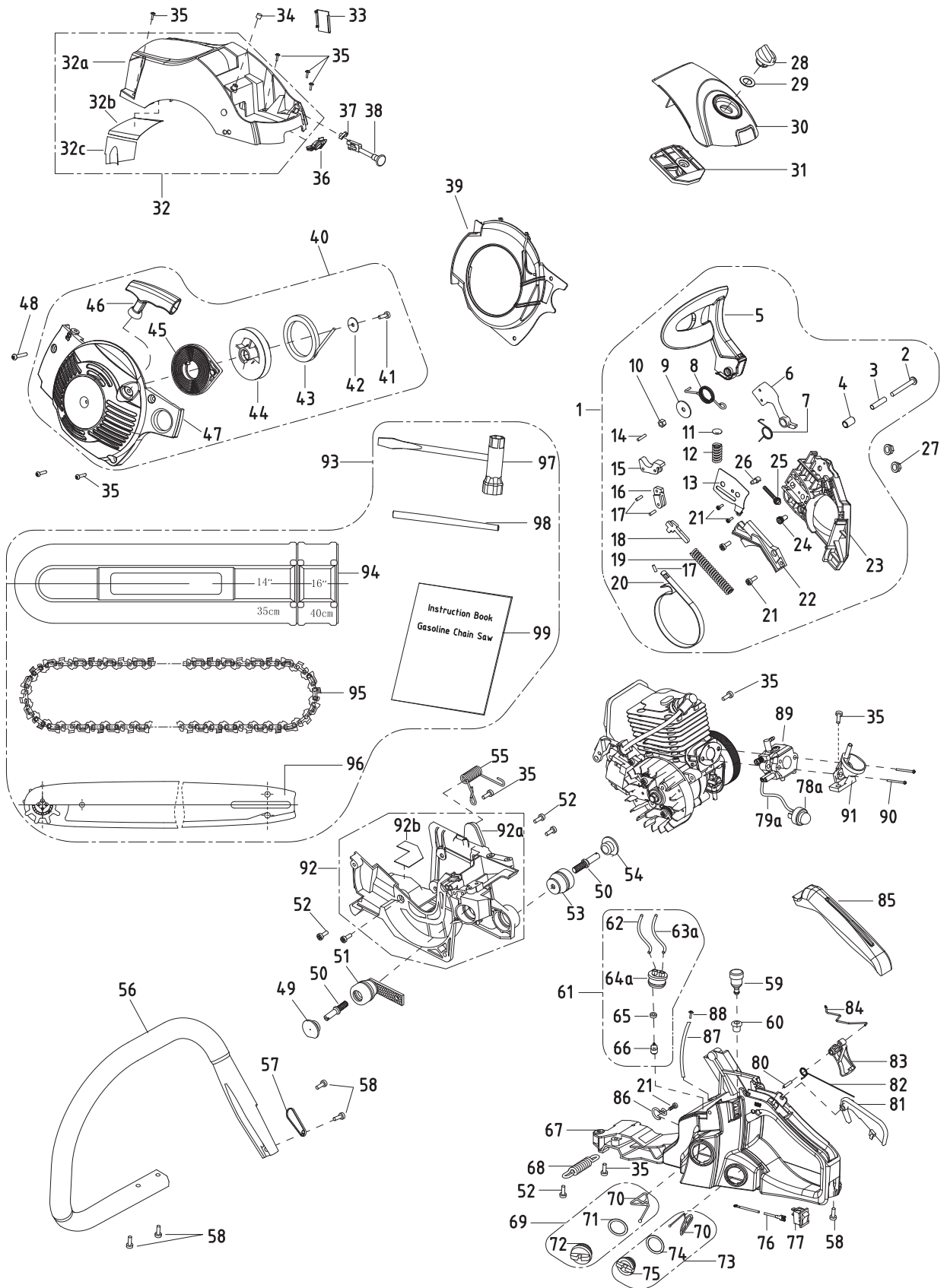

#	Part Number	Description	Qty
1	A38.0512.0000-18	Right Cover Assembly	1
2	A38.0312.0015	Screw M5 x 40	1
3	A38.0312.0012	Shield Gland	1
4	A38.0312.0011	Heavy Brock Gland	1
5	A38.0512.0001	Front Damper	1
6	A38.0312.0200	Heavy Block	1
7	A38.0312.0007	Heavy Block Spring	1
8	A38.0312.0008	Brake Torsion Rod Spring	1
9	A38.0312.0013-1	Washer 5.2 x 23 x 1.2	1
10	GB/T6183.1	Lock-Nut M5	1
11	A38.0312.0006-1	Spring Base	1
12	A38.0312.0005	Front Guard Spring	1
13	A38.0312.0014	Tensioner Cover Plate	1
14	GB/T119.2	Pin 3 x 14	1
15	A38.0312.0004-18	Main Lever	1
16	A38.0312.0003-18	Secondary Pull-Rod	1
17	01.05.0161	Pin 3 x 9	3
18	A38.0312.0010	Brake Control Rod	1
19	A45.0112.0009	Brake Spring	1
20	A38.0312.0009	Brake Strap	1
21	01.01.4121	Tapping Screw St4.2 x 9.5	5
22	A38.0312.0001	Brake Spring Cover Plate	1
23	A38.0512.0100-37	Right Cover	1
24	A45.0112.0023	Tension Gear	1
25	A45.0112.0018	Tightener Screw	1
26	A45.0112.0022	Tension Block	1
27	GB/T6177.1	Nut M8	2
28	A45.0113.0100	Air Filter Lock Nut	1
29	A45.0113.0005	Lock Nut Washer 15 x 26 x 1	1
30	A38.0513.0002-42	Air Filter Cover, 109C Yellow	1
31	A38.0304.0000	Air Filter	1
32	A38.0513.0000	Upper Cover Assembly	1
32a	A38.0513.0001-42	Upper Cover Plate, 109C Yellow	1
32b	A38.0513.0003	Upper Heat Isolation Plate	1
32c	A38.0513.0004	Side Heat Isolation Plate	1
33	A38.0313.0005	Anti-Freeze Block	1
34	A38.0313.0004	Shock Block	1
35	01.01.3031	Tapping Screw St4.8 x 16	10
36	A38.0300.0005	Dust Shield	1
37	A38.0300.0008	Choke Lever Retaining Bracket	1
38	A38.0500.0100	Choke Rod	1
39	A38.0500.0001	Bossing	1
40	A38.0510.0000	Starter Assembly	1
41	01.01.3031	Tapping Screw St 5 x 16	1
42	01.04.0161	Washer Ø5	1
43	A38.0310.0003	Start Stretching Wire 3 x 920	1
44	A38.0310.0001	Start Plate	1
45	A45.0110.0004	Start Coil-Spring	1
46	A62.0110.0002	Start Handle	1
47	A38.0510.0100-43	Start Cover, 109C Yellow	1
48	01.01.3201	Tapping Screw St4.8 x 19	1
49	A45.0100.0002	Dust Cover	1
50	A25.0100.0016	Bolt	2
51	A38.0307.0400	Cushion Socket	1
52	01.01.3191	Screw M5 x 14	5
53	A38.0307.0300	Cushion Socket	1
54	A38.0300.0006	Dust Cover	1
55	A38.0300.0002	Front Handle Spring	1

#	Part Number	Description	Qty
56	A38.0300.0001C	Front Handle	1
57	A38.0300.0010-1	Torsion Rod Spring Cover Plate	1
58	01.01.3041	Tapping Screw St4.8 x 25	5
59	A45.0111.0200	Balancer Body Assembly	1
60	A38.0311.0006	Balancer Root	1
61	12.01.0001	Fuel Tube Assembly	1
62	03.01.2.189	Fuel Tube	1
63a	A38.0311.0014	Turn Round Tube	1
64a	A38.0311.0005	Fuel Tube Seat	1
65	A38.0311.0015	Heavy Block	1
66	A38.0311.0400	Petrol Filter Components	1
67	A38.0511.0100-59	Base	1
68	A38.0300.0003	Base Spring	1
69	A38.0611.0200	Petrol Cover Assembly	1
70	A38.0311.0302	Anti-Drop Plate	2
71	03.01.2.100	O Ring 24.7 x 3.55	1
72	A38.0611.0201-27	Petrol Cover	1
73	A38.0611.0300	Oil Cover Assembly	1
74	03.01.2.110	O Ring 19 x 3.5	1
75	A38.0611.0301-22	Oil Cover	1
76	A38.0306.0400	Ground Conductor	1
77	A38.0306.0500-36	Extinction Switch	1
78a	A38.0311.0100	Primer Pump	1
79a	A38.0311.0013	Pump Tube	1
80	01.05.0081	Pin 5 x 25	1
81	A38.0511.0001-19	Trigger Control Rack	1
82	A45.0111.0005	Trigger Torsion Rod Spring	1
83	A38.0311.0009-47	Trigger	1
84	A38.0500.0002	Throttle	1
85	A38.0511.0002	Handle Cover	1
86	A38.0311.0012	Circlip For Nozzle	1
87	A38.0311.0008	Vent Tube 3.5 x 6.5 x 80	1
88	01.01.3121	Tapping Screw St4.2 x 14	1
89	06.08.02.840A	Carburetor	1
90	06.06.256	Carburetor Screw	2
91	A38.0301.0500	Air Intake Support	1
92	A38.0507.0000	Engine Base Assembly	1
92a	A38.0507.0100	Case	1
92b	A38.0307.0001	Engine Base Heat Isolation Plate	1
93	A38.0319.0000	Accessories	1
94	A38.0315.0001	Bar Cover	1
95	07.04.1.06.409	18"Chain	1
96	07.04.1.04.402	18"Guide Bar	1
97	A45.0119.0100	Plug Wrench	1
98	A38.0319.0001	File	1

SPECIFICATIONS

Engine Parts Diagram

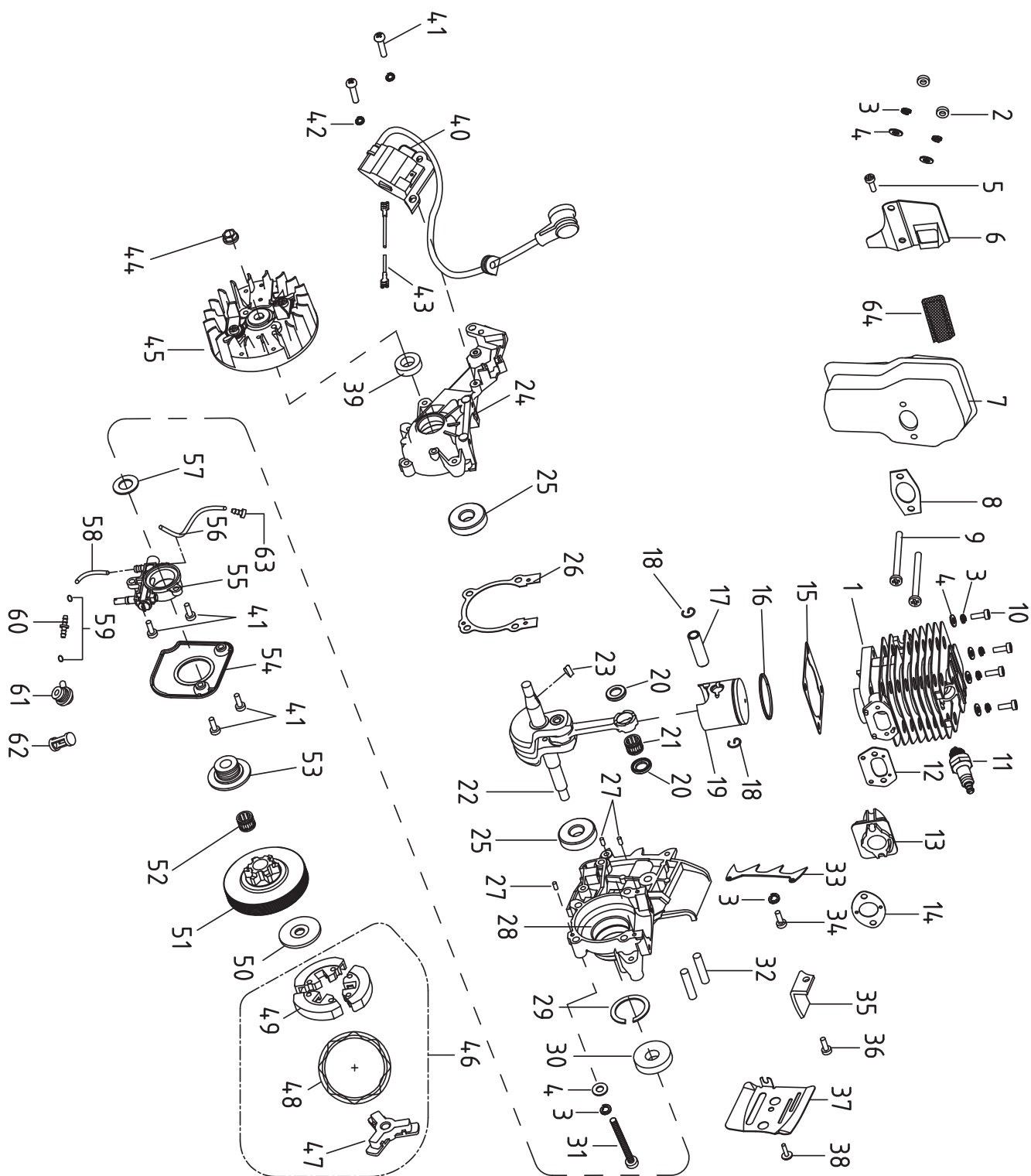

#	Part Number	Description	Qty
1	A41.0101.0001-5	Cylinder Body	1
2	01.03.0113	Nut M5	2
3	01.04.0091	Lock Washer 5	11
4	01.04.0121	Flat Washer 5	10
5	01.01.3191	Screw M5 × 14	1
6	A38.0305.0001	Silencer Cover Plate	1
7	A38.0305.0200-1	Silencer Body	1
8	A38.0301.0008	Silencer Sealing Gasket	1
9	06.06.226	Muffler Connecting Screw	2
10	01.01.6201	Screw M5 × 20	4
11	A45.0106.0500	Spark Plug, BOSCH L8RTF	1
12	A38.0301.0009	Air Intake Tube Sealing Gasket	1
13	A38.0301.0005	Air Intake Tube	1
14	A38.0301.0010	Carburetor Sealing Gasket	1
15	A38.0301.0007	Cylinder Sealing Gasket	1
16	A41.0103.0001A	Piston Ring	1
17	A38.0303.0002	Piston Pin	1
18	A38.0303.0003	Piston Pin Circlip	2
19	A41.0103.0100	Piston	1
20	A38.0303.0004	Needle Bearing Ring	2
21	A38.0303.0200	Needle Bearing 10 × 14 × 11	1
22	A38.0303.0100	Crank Shaft Components	1
23	A45.0101.0036	Semicircular Key 3 × 3.5 × 10	1
24	A38.0302.0001	Left Crank Case	1
25	01.05.1270	Bearing 6201 Grade D 12 × 32 × 10	2
26	A38.0302.0003	Case Body Sealing Gasket	1
27	01.05.0161	Pin 3 × 9	3
28	A38.0302.0002	Right Crank Case	1
29	01.04.1021	Shield Ring 32	1
30	A38.0302.0100	Oil Seal 12 × 32 × 5.5	1
31	01.01.6205	Screw M5X30	4
32	01.02.1061	Double-Screw Bolt Aym8- M8 × 26-8.8	2

#	Part Number	Description	Qty
33	A45.0101.0024	Spiked Bumper	1
34	01.01.6102	Screw M5 × 12	1
35	A38.0301.0016-1	Chain Catcher	1
36	A38.0301.0017	Chain Catcher Screw	1
37	A38.0301.0006	Damper	1
38	01.01.3061	Screw M4 × 10	1
39	A38.0302.0200	Oil Seal 12 × 22 × 7	1
40	A38.0306.1200	Igniter	1
41	01.01.3051	Screw M4 × 14	6
42	01.04.0191	Washer4	2
43	A38.0306.0300	Extinction Conductor	1
44	01.03.0073	Nut M8 × 1	1
45	A38.0306.1100	Flywheel Assembly	1
46	A38.0301.0300	Clutch Assembly	1
47	A38.0301.0301	Retainer	1
48	A38.0301.0303	Clutch Extension Spring	1
49	A38.0301.0302	Shoe Block	1
50	A38.0301.0002	Clutch Adjusting Washer	1
51	A38.0301.0001	Clutch Shell	1
52	A38.0301.0400	Needle Bearing 10 × 13 × 13	1
53	A38.0301.0014	Worm	1
54	A38.0300.0009	Cover Plate	1
55	A38.0314.0000	Oil Pump	1
56	A38.0314.0001	Oil Outgoing Tube 3 × 6.5 × 75	1
57	A38.0301.0015	Worm Washer 10 × 18 × 1	1
58	A38.0314.0004	Oil Ingoing Tube 3.3 × 6.5 × 68	1
59	A45.0102.0103	Oil Tube Clip	2
60	A38.0314.0005	Oil Tube Tie-In	1
61	A38.0314.0007	Nozzle	1
62	A38.0314.0008	Oil Filter Screen	1
63	A38.0314.0002	Oil Spray Nozzle	1
64	A38.0305.0002	Spark Arrester	1

TROUBLESHOOTING

Problem	Solution
ENGINE WILL NOT START	
The fuel tank is empty	Fill the fuel tank with properly mixed fuel
The primer bulb was not pressed enough	Press the primer bulb 10 times or until fuel is visible
The engine is flooded	Move the choke knob to Position 2, press the throttle lockout, squeeze the throttle control and pull the starter rope
The fuel is old (over 30 days) and/or improperly mixed	Drain the fuel tank and add fresh, properly mixed fuel
The spark plug is not working properly	Refer to <i>Maintaining the Spark Plug</i>
THE ENGINE WILL NOT IDLE	
The air filter is dirty	Clean or replace the air filter
The fuel is old (over 30 days) and/or improperly mixed	Drain the fuel tank and add fresh, properly mixed fuel
The idle speed is incorrect	Adjust the idle speed
THE ENGINE WILL NOT ACCELERATE	
The fuel is old (over 30 days) and/or improperly mixed	Drain the fuel tank and add fresh, properly mixed fuel
The air filter is dirty	Clean or replace the air filter
THE ENGINE LACKS POWER OR STALLS	
The fuel is old (over 30 days) and/or improperly mixed	Drain the fuel tank and add fresh, properly mixed fuel
The air filter is dirty	Clean or replace the air filter
The spark plug is not working properly	Refer to <i>Maintaining the Spark Plug</i>
THE GUIDE BAR AND SAW CHAIN ARE RUNNING HOT, SMOKING OR STUCK	
The saw chain tension is too tight	Adjust the saw tension
The chain reservoir is empty	Refill the chain oil reservoir
The guide bar groove and oil passages are dirty	Clean the guide bar and oil passages
The automatic oiler flow is too low	Increase the oil flow
THE SAW CHAIN DOES NOT ROTATE	
The saw chain tension is too tight	Adjust the saw chain tension
The guide bar and saw chain are assembled incorrectly	Refer to Moving and Installing the Guide Bar and Saw Chain
The guide bar and saw chain are damaged	Inspect the guide bar and saw chain for damage. Replace them if necessary
The drive assembly is damaged	Refer to Service information
The chain brake is engaged	Disengage the chain brake
THE SAW CHAIN ROTATES, BUT DOES NOT CUT	
The saw chain is dull	Sharpen or replace the saw chain
The saw chain is on backwards	Check and correct the saw direction

For further technical support:

Technical Service

Mon – Fri 8:30 AM – 5:00 PM (PST/PDT)

Toll Free: 1-877-338-0999

tech@championpowerequipment.com

Champion Power Equipment (CPE) warrants to the original consumer purchaser that each new CPE brand gasoline chainsaw is free from defects in material and workmanship and agrees to repair or replace under this warranty any defective gasoline chainsaw as follows from the original date of purchase.

2 YEARS - Parts and Labor, when used for household purposes.

30 DAYS - Parts and Labor, when used for commercial, professional, income producing purposes, or rental purposes.

This warranty is not transferable and does not cover damage or liability caused by improper handling, improper maintenance or alteration, or the use of accessories and/or attachments not specifically recommended by CPE for this chainsaw. This warranty does not cover tune-up, spark plugs, filters, starter ropes, chain sharpening, bars, chains, and other parts which wear and require replacement with reasonable use during the warranty period. This warranty does not cover predelivery setup, installation of guide bar and chain, and normal adjustments explained in the instruction manual such as chain tension adjustments.

This warranty does not cover transportation costs. In the event you have a claim under this warranty, you must return the product to an authorized service dealer.

Should you have any unanswered questions concerning this warranty, please contact CPE Customer Service.

Customer Service

Mon – Fri 8:30 AM – 5:00 PM (PST/PDT)

Toll Free: 1-877-338-0999

info@championpowerequipment.com

Fax no.: 1-562-236-9429

Give the model number, serial number and date of purchase of your product and the name and address of the authorized dealer from whom it was purchased.

THIS WARRANTY GIVES YOU SPECIFIC LEGAL RIGHTS, AND YOU MAY HAVE OTHER RIGHTS WHICH VARY FROM STATE-TO-STATE/PROVINCE-TO-PROVINCE. NO CLAIMS FOR CONSEQUENTIAL OR OTHER DAMAGES WILL BE ALLOWED, AND THERE ARE NO OTHER EXPRESS WARRANTIES EXCEPT THOSE EXPRESSLY STIPULATED HEREIN. SOME STATES/PROVINCES DO NOT ALLOW LIMITATIONS ON HOW LONG AN IMPLIED WARRANTY LASTS OR THE EXCLUSION OR LIMITATIONS OF INCIDENTAL OR CONSEQUENTIAL DAMAGES, SO THE ABOVE LIMITATIONS OR EXCLUSION MAY NOT APPLY TO YOU.

This is a limited warranty within the meaning of that term as defined in the Magnuson-Moss Act of 1975.

The policy of CPE is to continuously improve its products. Therefore, CPE reserves the right to change, modify, or discontinue models, designs, specifications, and accessories of all products at any time without notice or obligation to any purchaser.

**Champion Power Equipment, Inc (CPE) and Environment and Climate Change Canada (ECCC)
Emission Control System Warranty**

Your Champion Power Equipment (CPE) engine complies with Environment and Climate Change Canada (ECCC) emission regulations.

YOUR WARRANTY RIGHTS AND OBLIGATIONS:

CPE is pleased to explain the Emission Control Systems Warranty on your 2017 small off-road engine. New engines must be designed, built and equipped, at the time of sale, to meet ECCC regulations for small non-road engines. CPE must warrant the emission control system on your small off-road engine for the period of time listed below, provided there has been no abuse, neglect, unapproved modification, or improper maintenance of your small off-road engine.

Your emission control system may include parts such as the carburetor, fuel-injection system, the ignition system, catalytic converter and fuel lines. Also included may be hoses, belts, connectors and other emission related assemblies. Where a warrantable condition exists, CPE will repair your small off-road engine at no cost to you including diagnosis, parts and labour.

MANUFACTURER'S EMISSION CONTROL SYSTEM WARRANTY COVERAGE:

This emission control system is warranted for two years, subject to provisions set forth below. If, during the warranty period, emission related part on your engine is defective in materials or workmanship, the part will be repaired or replaced by CPE.

OWNER WARRANTY RESPONSIBILITIES:

As the small off-road engine owner, you are responsible for the performance of the required maintenance listed in your Owner's Manual. CPE recommends that you retain all your receipts covering maintenance on your small off-road engine, but CPE cannot deny warranty solely for the lack of receipts or for your failure to ensure the performance of all scheduled maintenance.

As the small off-road engine owner, you should however be aware that CPE may deny you warranty coverage if your small, off-road engine or a part has failed due to abuse, neglect, improper maintenance or unapproved modifications.

You are responsible for presenting your small off-road engine to an Authorized CPE service outlet, CPE dealer or CPE, Santa Fe Springs, CA., USA as soon as a problem exists. The warranty repairs should be completed in a reasonable amount of time, not to exceed 30 days.

If you have any questions regarding your warranty rights and responsibilities, you should contact:

Champion Power Equipment, Inc.
Customer Service
12039 Smith Ave.
Santa Fe Springs, CA 90670
USA
Tel: 1-877-338-0999
tech@championpowerequipment.com

EMISSION CONTROL SYSTEM WARRANTY

The following are specific provisions relative to your Emission Control System Warranty Coverage.

Emission Control System Warranty (ECS Warranty):

1. APPLICABILITY: The ECS Warranty Period shall begin on the date the new engine or equipment is delivered to its original, end-use purchaser, and shall continue for 24 consecutive months thereafter.

2. GENERAL EMISSIONS WARRANTY COVERAGE

CPE warrants to the original, end-use purchaser of the new engine or equipment and to each subsequent purchaser that each of its small off-road engines is:

a. Designed, built and equipped so as to conform at the time of sale with applicable regulations under the Canadian Environmental Protection Act, 1999 (CEPA 1999).

b. Free from defects in materials and workmanship that cause the failure of a warranted part to be identical in all material respects to the part as described in the engine manufacturer's application for certification for a period of two years.

3. THE WARRANTY ON EMISSION-RELATED PARTS WILL BE INTERPRETED AS FOLLOWS:

a. Any warranted part that is not scheduled for replacement as required maintenance in the Owners Manual shall be warranted for the ECS Warranty Period. If any such part fails during the ECS Warranty Period, it shall be repaired or replaced by CPE according to Subsection "d" below. Any such part repaired or replaced under the ECS Warranty shall be warranted for any remainder of the ECS Warranty Period.

b. Any warranted, emissions-related part which is scheduled only for regular inspection as specified in the Owners Manual shall be warranted for the ECS Warranty Period. A statement in such written instructions to the effect of "repair or replace as necessary", shall not reduce the ECS Warranty Period. Any such part repaired or replaced under the ECS Warranty shall be warranted for the remainder of the ECS Warranty Period.

c. Any warranted, emissions-related part which is scheduled for replacement as required maintenance in the Owner's Manual shall be warranted for the period of time prior to the first scheduled replacement point for that part. If the part fails prior to the first scheduled replacement, the part shall be repaired or replaced by CPE according to Subsection "d" below. Any such emissions-related part repaired or replaced under the ECS Warranty, shall be warranted for the remainder of the ECS Warranty Period prior to the first scheduled replacement point for such emissions-related part.

d. Repair or replacement of any warranted, emissions-related part under this ECS Warranty shall be performed at no charge to the owner at a CPE Authorized Service Outlet.

e. The owner shall not be charged for diagnostic labour which leads to the determination that a part covered by the ECS Warranty is in fact defective, provided that such diagnostic work is performed at a CPE Authorized Service Outlet.

f. CPE shall be liable for damages to other original engine components or approved modifications proximately caused by a failure under warranty of an emission-related part covered by the ECS Warranty.

g. Throughout the ECS Warranty Period, CPE shall maintain a supply of warranted emission-related parts sufficient to meet the expected demand for such emission-related parts.

h. Any CPE Authorized and approved emission-related replacement part may be used in the performance of any ECS Warranty maintenance or repair and will be provided without charge to the owner. Such use shall not reduce CPE's warranty obligation.

i. Unapproved add-on or modified parts may not be used to modify or repair a CPE engine. Such use voids this ECS Warranty and shall be sufficient grounds for disallowing an ECS Warranty claim. CPE shall not be liable hereunder for failures of any warranted parts of a CPE engine caused by the use of such an unapproved add-on or modified part.

EMISSION-RELATED PARTS INCLUDE THE FOLLOWING: (using those portions of the list applicable to the engine)

Systems covered by this warranty	Parts description
Fuel Metering System	Fuel regulator, carburetor and internal parts
Air Induction System	Air cleaner, intake manifold
Ignition System	Spark plug and parts, magneto ignition system
Exhaust System	Exhaust manifold, catalytic converter
Miscellaneous Parts	Tubing, fittings, seals, gaskets, and clamps associated with these listed systems.
Evaporative Emissions	Fuel tank, fuel cap, fuel line, fuel line fittings, clamps, pressure relief valves, control valves, control solenoids, electronic controls, vacuum control diaphragms, control cables, control linkages, purge valves, vapour hoses, liquid/ vapour separator, carbon canister, canister mounting brackets, carburetor purge port connector

TO OBTAIN WARRANTY SERVICE:

You must take your CPE engine or the product on which it is installed, along with your warranty registration card or other proof of original purchase date, at your expense, to any Champion Power Equipment dealer who is authorized by Champion Power Equipment, Inc. to sell and service that CPE product during his normal business hours. Claims for repair or adjustment found to be caused solely by defects in material or workmanship will not be denied because the engine was not properly maintained and used.

If you have any questions regarding your warranty rights and responsibilities, or to obtain warranty service, please write or call Customer Service at Champion Power Equipment, Inc.

**Champion Power Equipment, Inc.
12039 Smith Ave.
Santa Fe Springs, CA 90670
USA
1-877-338-0999
Attn: Customer Service
tech@championpowerequipment.com**