

CHAMPION

POWER EQUIPMENT TM-MC

OPERATOR'S MANUAL



43cc CULTIVATOR



MODEL NUMBER
100378

SAVE THESE INSTRUCTIONS
Important safety instructions
are included in this manual.

MADE IN CHINA
REV 100378-20170216

12039 Smith Ave.
Santa Fe Springs CA 90670
USA / 1-877-338-0999
www.championpowerequipment.com

Have questions or need assistance?

Do not return this product to the store!

WE ARE HERE TO HELP!

Visit our website:

www.championpowerequipment.com

for more info:

- Product Info & Updates
- Tech Bulletins
- Frequently Asked Questions
- Product Registration

– or –

Call our Customer Care Team Toll-Free at:

1-877-338-0999

Parts Ordering:

Mon – Fri 8:30 AM – 5:00 PM (PST/PDT)

Toll Free: 1-877-338-0999

For residents of California:

WARNING: This product contains chemicals known to the State of California to cause cancer or birth defects and other reproductive harm.

WARNING: The engine exhaust from this product contains chemicals known to the State of California to cause cancer and birth defects and other reproductive harm.

*We are always working to improve our products. Therefore, the enclosed product may differ slightly from the image on the cover.

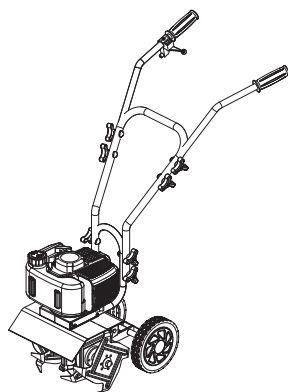

43cc CULTIVATOR

TABLE OF CONTENTS

Introduction	1	Muffler	14
Manual Conventions	2	Intake Air Cooling Vent	15
Safety Rules	3	Procedures to be Performed After Every 100 Hours of Use	15
Symbols	3	Maintenance Schedule	15
Things To Do	5	Cultivator Storage	15
Things Not To Do	6	How to Prepare Your Cultivator for Restarting ..	16
Controls and Features	7	Re-Starting problems after storage	16
Cultivator	7	Troubleshooting	17
Assembly	8	Starting Problems	17
Tine Installation or Re-installation	8	Specifications	18
Wheel Assembly	8	Engine Specifications	18
Handle Assembly	9	Cultivator Specifications	18
Fuel	9	Spark Plugs	18
How to mix fuel	9	Parts Diagram	19
Fueling the unit	9	Parts List	20
Operation	11	Engine Parts Diagram	21
Starting Instructions	11	Engine Parts List	22
Starting Your Cultivator for the First Time or When Cold	11	Warranty	23
Starting a Warm Engine	12		
Stopping the Engine	12		
Special Feature (with Idle Set Properly and the Engine Running)	12		
Tips for Extending Engine Life	12		
Cultivating	12		
Now You're ready to Use Your Cultivator ..	12		
You Can Even Control Depth	12		
Maintenance and Storage	14		
Cultivator Maintenance	14		
How to Check, Clean and Change the Air Filter	14		
Cleaning Air Filter	14		
Idle Speed Adjustment	14		
Clear Blockages From the Fuel Line & Filter ..	14		
Spark Plug	14		

INTRODUCTION

Congratulations on your purchase of a Champion Power Equipment (CPE) product. CPE designs, builds, and supports all of our products to strict specifications and guidelines. With proper product knowledge, safe use, and regular maintenance, this product should bring years of satisfying service.

Every effort has been made to ensure the accuracy and completeness of the information in this manual, and we reserve the right to change, alter and/or improve the product and this document at any time without prior notice.

Since CPE highly values how our products are designed, manufactured, operated and are serviced, and also highly value your safety and the safety of others, we would like you to take the time to review this product manual and other product materials thoroughly and be fully aware and knowledgeable of the assembly, operation, dangers and maintenance of the product before use. Fully familiarize yourself, and make sure others who plan on operating the product fully familiarize themselves too, with the proper safety and operation procedures before each use. Please always exercise common sense and always err on the side of caution when operating the product to ensure no accidents, property damage, or injury occurs. We want you to continue to use and be satisfied with your CPE product for years to come.

Record the model and serial numbers as well as date and place of purchase for future reference. Have this information available when ordering parts and when making technical or warranty inquiries.

Champion Power Equipment Support
1-877-338-0999
Model Number
100378
Serial Number
Date of Purchase
Purchase Location

This manual uses the following symbols to help differentiate between different kinds of information. The safety symbol is used with a key word to alert you to potential hazards in operating and owning power equipment.

Follow all safety messages to avoid or reduce the risk of serious injury or death.

 **DANGER**

DANGER indicates an imminently hazardous situation which, if not avoided, **will** result in death or serious injury.

 **WARNING**

WARNING indicates a potentially hazardous situation which, if not avoided, **could** result in death or serious injury.

 **CAUTION**

CAUTION indicates a potentially hazardous situation which, if not avoided, **may** result in minor or moderate injury.

CAUTION

CAUTION used without the safety alert symbol indicates a potentially hazardous situation which, if not avoided, **may** result in property damage.









 **NOTE**

If you have questions regarding your cultivator, we can help. Please call our help line at **1-877-338-0999**

SAFETY RULES

Some of the following symbols may be used on this product. Please study them and learn their meaning. Proper interpretation of these symbols will allow you to more safely operate the product.

Symbols

Symbol	Meaning
	Precautions that involve your safety.
	To reduce risk of injury, user must read and understand operator's manual before using this product.
	Always wear safety goggles, safety glasses with side shields, or a full face shield, as well as hearing protection when using this product.
	Keep all bystanders at least 50 ft. (15.2 m) away.
	Keep hands away from rotating tines.
	Keep feet away from rotating tines.
	Engine ON / START / RUN
	Engine OFF or STOP

⚠ WARNING

Read this manual thoroughly before operating your cultivator. Failure to follow instructions could result in serious injury or death.

⚠ WARNING

The engine exhaust from this product contains chemicals known to the state of California to cause cancer, birth defects, or other reproductive harm.

⚠ DANGER

Engine exhaust contains carbon monoxide, a colorless, odorless, poison gas. Breathing carbon monoxide will cause nausea, dizziness, fainting or death. If you start to feel dizzy or weak, get to fresh air immediately.

Operate the cultivator outdoors only in a well ventilated area. DO NOT operate the cultivator inside any building, enclosure or compartment. DO NOT allow exhaust fumes to enter a confined area through windows, doors, vents or other openings. **DANGER: CARBON MONOXIDE** - using an engine indoors **CAN KILL YOU IN MINUTES.**

⚠ DANGER

Rotating parts can entangle hands, feet, hair, clothing and/or accessories. Traumatic amputation or severe laceration can result.

Keep hands and feet away from rotating parts. Tie up long hair and remove jewelry. Operate equipment with guards in place. DO NOT wear loose-fitting clothing, dangling drawstrings or items that could become caught.

⚠ DANGER

Sparks can result in fire or electrical shock.

When servicing the engine:

Disconnect the spark plug wire and place it where it cannot contact the plug. DO NOT check for spark with the plug removed. Use only approved spark plug testers.

⚠ WARNING

Running engines produce heat. Severe burns can occur on contact. Combustible material can catch fire on contact.

DO NOT touch hot surfaces. Avoid contact with hot exhaust gases. Allow equipment to cool before touching. Maintain at least 3 ft. (91.4 cm) of clearance on all sides to ensure adequate cooling. Maintain at least 5 ft. (1.5 m) of clearance from combustible materials.

⚠ WARNING

Rapid retraction of the starter cord will pull hand and arm towards the engine faster than you can let go. Unintentional startup can result in entanglement, traumatic amputation or laceration. Broken bones, fractures, bruises or sprains could result.

When starting engine, pull the starter cord slowly until resistance is felt and then pull rapidly to avoid kickback.

SAFETY RULES

DANGER

Fuel and fuel vapors are highly flammable and extremely explosive.

Fire or explosion can cause severe burns or death.

Unintentional startup can result in entanglement, traumatic amputation or laceration.

When adding or removing fuel:

Turn the engine off and let it cool for at least two minutes before removing the fuel cap. Loosen the cap slowly to relieve pressure in the tank.

Only fill or drain fuel outdoors in a well-ventilated area.

DO NOT pump gas directly into the engine at the gas station. Use an approved container to transfer the fuel to the engine.

DO NOT overfill the fuel tank.

Always keep fuel away from sparks, open flames, pilot lights, heat and other sources of ignition.

DO NOT light or smoke cigarettes.

When starting the engine:

DO NOT attempt to start a damaged engine. Make certain that the gas cap, air filter, spark plug, fuel lines and exhaust system are properly in place. Allow spilled fuel to evaporate fully before attempting to start the engine.

Make certain that the cultivator is resting firmly on level ground.

Things To Do

1. Always keep a firm grip on both handles while the tines are moving and/or the engine is running. **BE AWARE!!** The tines may coast after throttle trigger is released. Make sure tines have come to a complete stop and engine is off before letting go of the cultivator handles.
2. Always maintain a firm footing and good balance. Do not overreach while operating the cultivator. Before you start to use the cultivator, check the work area for obstacles that might cause you to lose your footing, balance or control of the machine.
3. Thoroughly inspect the area where equipment is to be used and remove all objects, that can be thrown by the machine or cause it to jam.
4. Keep all bystanders, children, and pets at least 50 ft. (15.2 m) away.
5. Always stay alert. Watch what you are doing and use common sense. Do not operate unit when fatigued.
6. Always dress properly. Do not wear loose clothing or jewelry, they might get caught in moving parts. Use sturdy gloves. Gloves reduce the transmission of vibration to your hands. Prolonged exposure to vibration can cause numbness, fatigue and other ailments.
7. While working, always wear substantial footwear and long trousers. Do not operate the equipment when barefoot or wearing open sandals.
8. Always wear ear and eye protection. Eye protection must meet ANSI Z87.1. To avoid hearing damage, we recommend hearing protection be worn whenever using the equipment.
9. To reduce fire hazard, keep the engine, and petrol/ gas storage area free of vegetative material and excessive grease.
10. Start the engine carefully, according to the instructions and with feet well away from the tines.
11. Always operate the cultivator with good visibility
12. Keep all nuts, bolts and screws tight to be sure the equipment is in safe working condition.
13. Use extreme caution when reversing or pulling the machine towards you.
14. Stop the engine and disconnect the spark plug before unclogging the tines and when making any repairs, adjustments, or inspections.
15. Work only in daylight or good artificial light.
16. Always be sure of your footing on slopes.
17. Exercise extreme caution when changing direction on slopes.

Things To Do Cont'd.

18. Always keep a safe distance between two or more people when working together.
19. Always inspect your unit before each use and ensure that all handles, guards and fasteners are secure, operating, and in place.
20. Always maintain and examine your cultivator with care. Follow maintenance instructions given in manual.
21. Always use fresh gasoline. Stale gasoline can cause engine damage.
22. Always store fuel in containers specifically designed for that purpose.
23. Always pull starter cord slowly until resistance is felt. Then pull cord rapidly to avoid kickback and prevent arm or hand injury.
24. Stop the engine whenever you leave the machine.
25. Allow the engine to cool before storing in any enclosure.
26. If the fuel tank needs to be drained, this should be done outdoors.

Things Not To Do

1. Don't use the cultivator with one hand. Keep both hands on the handles with fingers and thumbs encircling the handles while tines are moving and engine is running.
2. Don't put hands or feet near or under tines.
3. Do not use near underground electric cables, telephone lines, pipes, or hoses. If in doubt, contact your utility or telephone company to locate underground services.
4. Don't overreach. Keep a good footing at all times.
5. Don't run with the machine only walk.
6. Don't work on excessively steep slopes.
7. Don't attempt to clear tines while they are moving. Never try to remove jammed material before switching the engine off and making sure the tines have stopped completely.
8. Don't allow children to operate this cultivator.
9. Don't allow adults to operate the equipment without proper instruction.
10. Don't operate while under the influence of alcohol or drugs.

Things Not To Do Cont'd.

11. Don't fuel, refuel or check fuel while smoking, or near an open flame or other ignition source. Stop engine and be sure it is cool before refueling.
12. Don't leave the engine running while the cultivator is unattended. Stop engine before putting the cultivator down or while transporting from one place to another.
13. Don't refuel, start or run this cultivator indoors or in an improperly ventilated area.
14. Don't run engine when electrical system causes spark outside the cylinder. During periodic checks of the spark plug, keep plug a safe distance from cylinder to avoid burning of evaporated fuel from cylinder.
15. Don't check for spark with spark plug or plug wire removed. Use an approved tester.
16. Don't crank engine with spark plug removed unless spark plug wire is disconnected. Sparks can ignite fumes.
17. Don't run engine when the odor of gasoline is present or other explosive conditions exist.
18. Don't operate the unit if gasoline is spilled. Clean up spill completely before starting engine.
19. Don't operate your cultivator if there is an accumulation of debris around the muffler, and cooling fins.
20. Don't touch hot mufflers, cylinders or cooling fins as contact may cause serious burns.
21. Don't change the engine governor setting or over speed the engine.

CONTROLS AND FEATURES

Read this owner's manual before operating your cultivator. Familiarize yourself with the location and function of the controls and features. Save this manual for future reference.

Cultivator

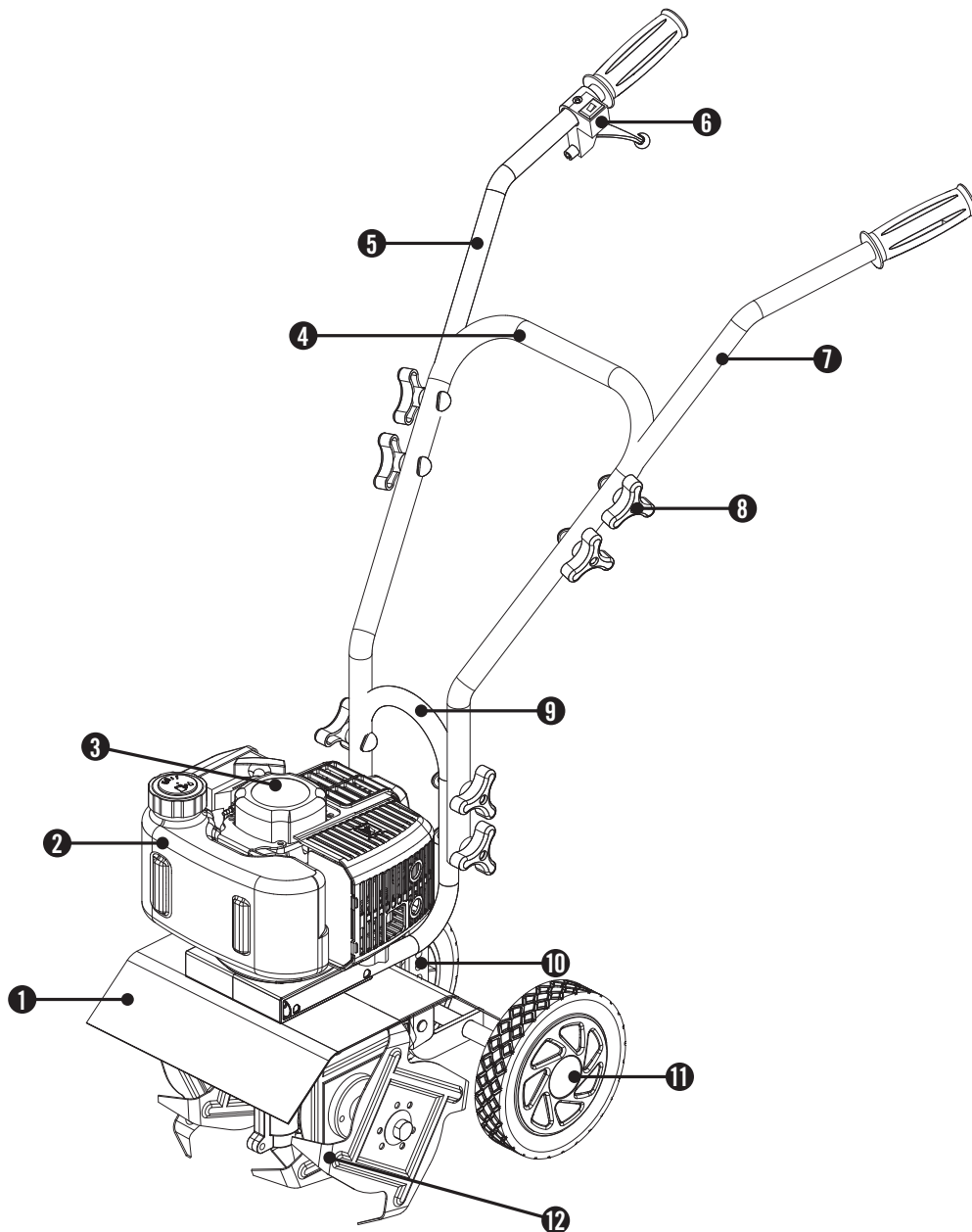

- | | |
|---|--------------------|
| (1) Fender Guard | (7) Left Handle |
| (2) Fuel Tank – 0.3 gal (1.1 L), 50:1 ratio | (8) Knob Handle |
| (3) Engine – 43cc | (9) Lower Handle |
| (4) Middle Handle | (10) Axle Assembly |
| (5) Right Handle | (11) Wheel |
| (6) Throttle | (12) Tine Assembly |

Read this owner's manual before operating your cultivator. If you have any questions regarding the assembly of your cultivator, call our help line at 1-877-338-0999. Please have your serial number and model number available.

Tine Installation or Reinstallation

1. First, slide the inside tines onto each end of the tine shaft. One inside tine is stamped with a "B" and the other is stamped with a "C".
2. Slide the outside tine "A" and tine "D" onto each end of the shaft next. The tines should be installed in the correct order so that they are positioned right to left A, B, C, D, as viewed from the front of the cultivator. Make sure that the hub collars on both the right and left pairs of tines face each other so that there is adequate spacing between the tine blades.

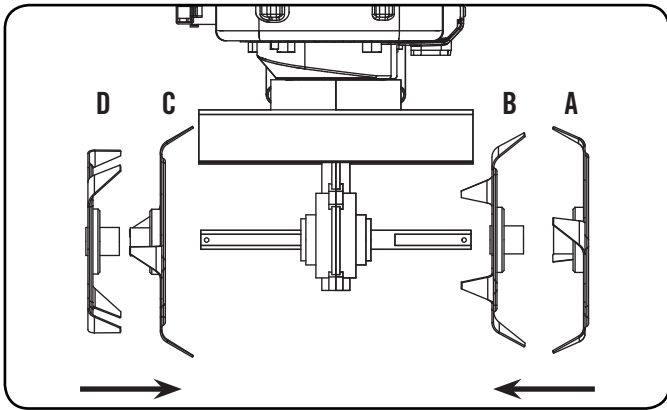

3. Slide a washer on each side.
4. Insert the cotter pins into the holes at each end of the tine shaft to lock the tines into place.

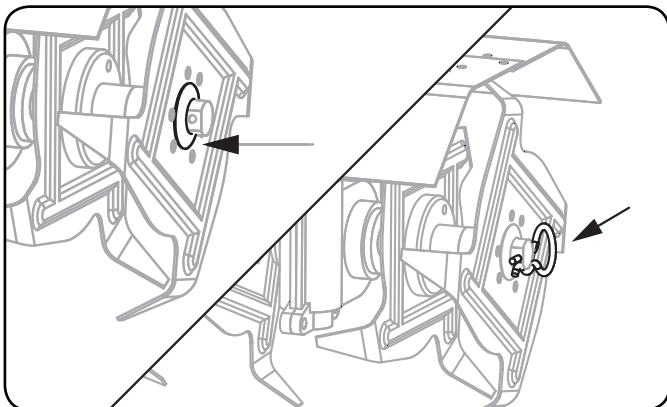

Wheel Assembly

1. Remove the cotter pin from the clevis pin.

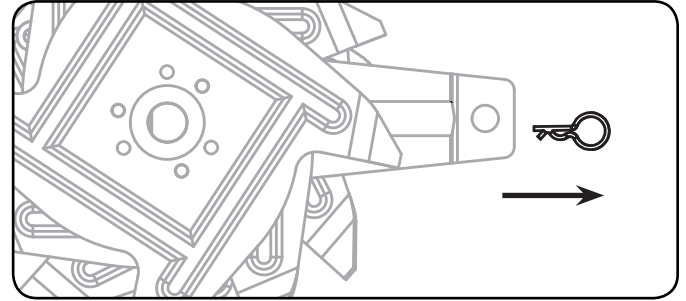

2. Remove the clevis pin from the axle assembly.

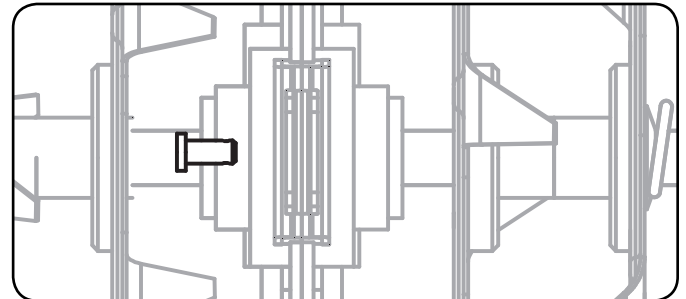

3. Place wheel on each end of the axle. Note installation direction - ring faces outwards.

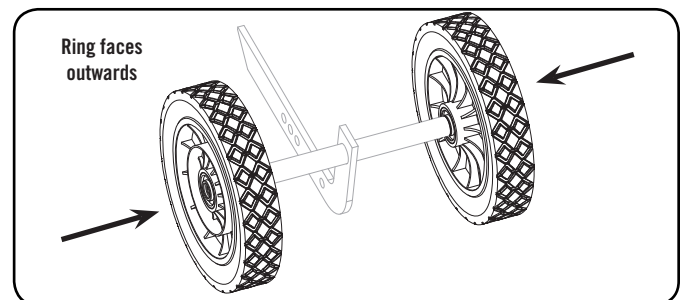

4. Slide a washer onto the axle on each side. Add the nut and hand tighten.

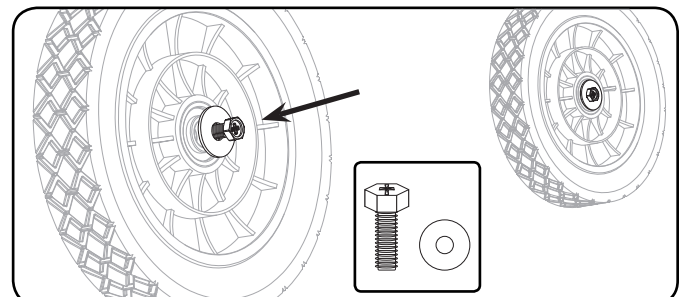

ASSEMBLY

Wheel Assembly Cont'd.

- Snap hubcap to outside of each wheel.

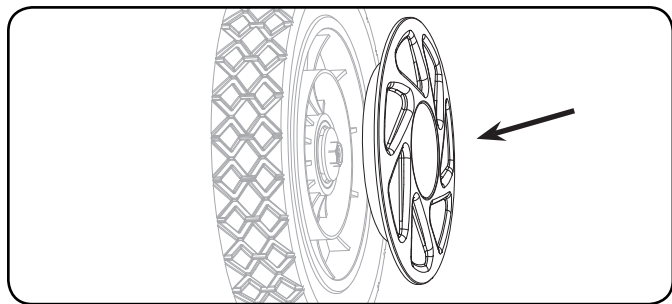

- Attach wheel assembly to main body, reverse steps 1-2.

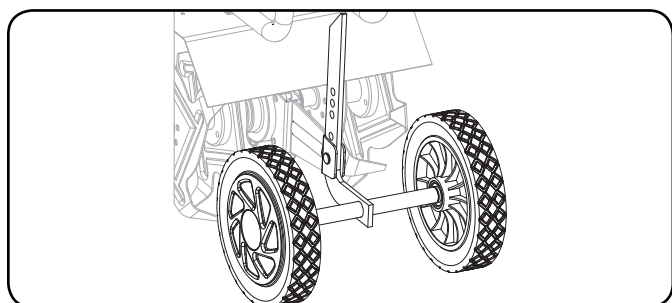

Handle Assembly

- Attach the middle handle to the lower handle using the knobs and bolts provided. The knobs should be on the outside.

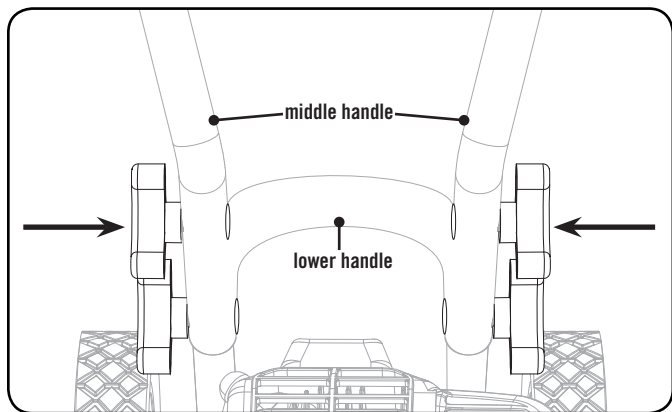

- Attach the left handle and right handle to the middle handle using the knobs and bolts provided. The knobs should be on the outside.

Handle Assembly Cont'd

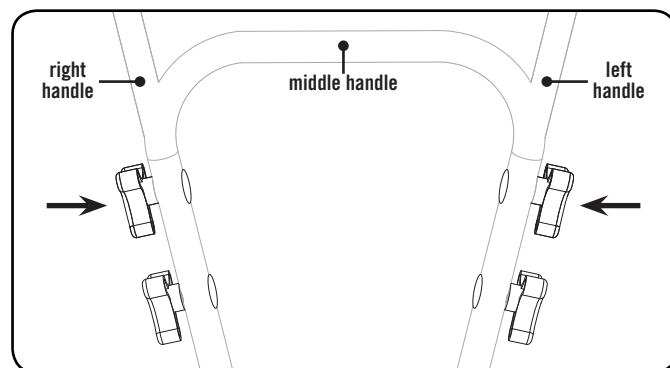

Fuel

Your cultivator is powered by a two stroke engine which requires a fuel mixture of gasoline and lubricating oil.

Use a mixture of 50 parts unleaded regular gasoline and 1 part two-stroke oil (50:1.) Use unleaded gasoline intended for motor vehicle use with an octane rating of 87 [(R + M)/2] or higher. Never use fuel containing more than 10% ethanol.

Recommended mixing ratio Gasoline 50: Oil 1

Exhaust emission are controlled by the fundamental engine parameters and components (eq. carburetors, ignition timing and port timing) without addition of any major hardware or the introduction of an inert material during combustion.

How to mix fuel

- Pour 1 gal. (3.8 L) of the gasoline into a safe container. Do not mix the fuel and oil in the engine fuel tank.
- Add 2.6 oz (76 mL) of two-cycle engine oil to the gasoline and mix well. Screw the cap onto the gasoline can. Then swirl the can to blend the oil and gas.

Fueling the unit

- Carefully pour the fuel mix into the cultivator's fuel tank.
- Only fill the fuel tank to 80% of the full capacity.
- Fasten the fuel cap securely and wipe up any fuel spillage around the unit.

Fuel Cont'd.

! IMPORTANT

- Always re-mix two-cycle fuel before fueling your cultivator. Never, run your cultivator on gasoline alone. This will ruin your engine and void all warranties.
- Always use a clean gas can and always use unleaded gas with less than 10% ethanol.
- Never try to mix the oil and gasoline in the engine fuel tank.
- Always mix oil and gas in the proper proportions: 2.6 oz (76 mL) of two-cycle engine oil to 1 gallon (3.8 L) of unleaded gasoline. Pre-mixed fuels like 50:1 TruFuel are also a good options to fuel your cultivator.
- Ethanol – High levels of ethanol can cause deterioration of rubber and/or plastic parts and disruption of engine lubrication. Never use fuel containing more than 10% ethanol.

⚠ DANGER

Fuel is extremely flammable. Handle it with care. Keep away from ignition sources. DO NOT smoke while fueling your equipment.

NOTE

DO NOT use old or stale oil/gasoline mixture. Always use the proper oil/gasoline mixture. Not following these instructions will cause your engine to suffer rapid, permanent, damage, AND will void the engine warranty.

Gasoline gal. (L)	1 gal. (3.8 L)	2 gal. (7.6 L)	3 gal. (11.4 L)	4 gal. (15.1 L)	5 gal. (18.9 L)
2-Cycle Oil oz. (mL)	2.6 oz. (76 mL)	5.1 oz. (152 mL)	7.7 oz. (228 mL)	10.2 oz. (302 mL)	12.9 oz. (378 mL)

OPERATION

Starting Instructions

Starting Your Cultivator for the First Time or When Cold

1. Fill the fuel tank with the proper oil/gasoline mixture. (See previous section.)
2. Hand tighten the gasoline cap until it's snug.
3. Move engine switch on the handle into the "ON" position.

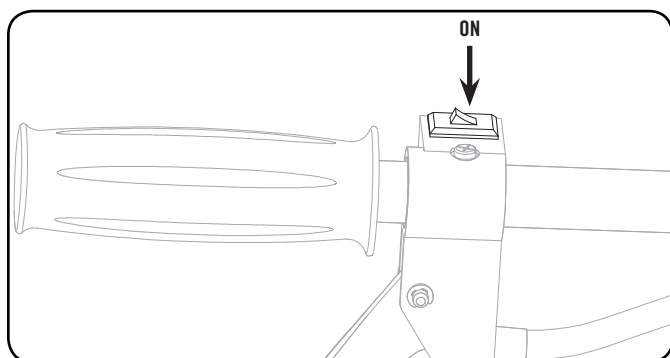

4. Slide the choke lever to "START" to engage the engine choke.

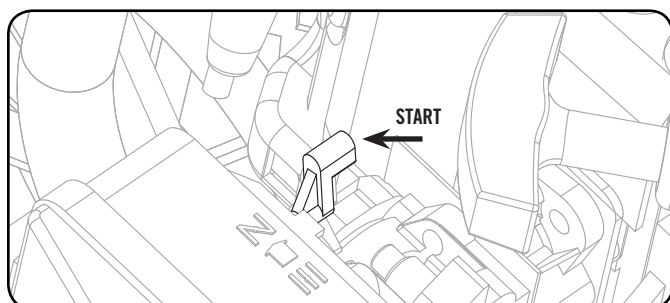

5. Locate the primer bulb on the upper right of the engine, in front of the fuel tank. Press the primer bulb until you see fuel flow through the clear fuel return line. Starting the engine "cold," press the primer bulb five times.

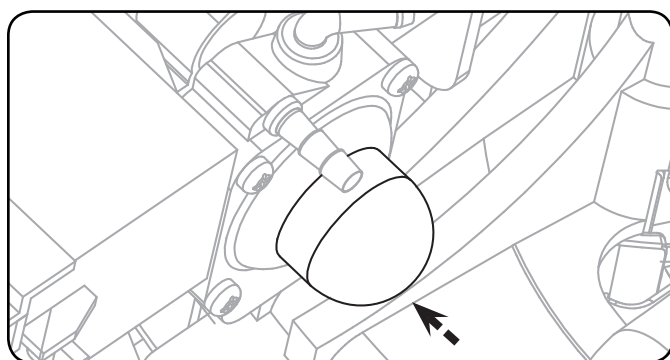

- a. Press and hold the fuel button while you press the primer bulb one to two times again.

Starting Your Cultivator for the First Time or When Cold Cont'd.

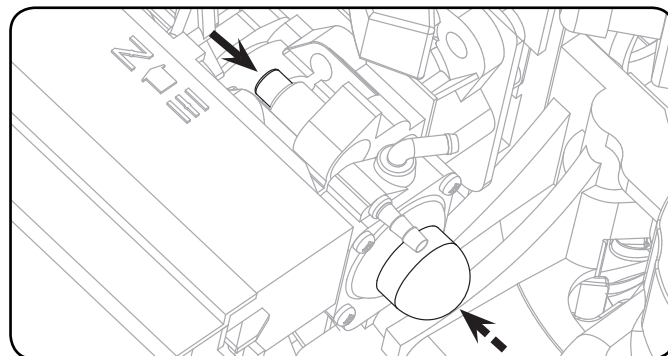

6. Don't pull the throttle trigger during the starting of the engine.
7. Keeping the choke in the "START" position, pull the starter cord slowly until resistance is felt. Then give the recoil starter cord a few short, brisk pulls until the engine starts. During cold starting, you may need to pull at least three or four times before the engine starts. Starting a "warm" engine should not require the choke to be engaged.
8. Once the engine starts after a few seconds slide the choke lever to "RUN" slowly to turn off the engine choke.

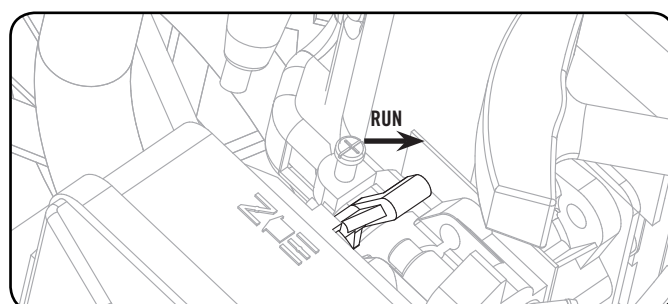

9. Give the recoil starter cord a few short, brisk pulls until the engine starts. The engine should start and run. Let the engine warm up two to three minutes before using.
10. With engine running, and both hands on the handles, squeeze throttle trigger gradually to increase the engine speed and engage the tines.

Starting a Warm Engine

1. Move the engine switch to the "ON" position.
2. Ensure the choke lever is in the "RUN" position.
3. If there is no fuel in the clear return line, push primer bulb 3-4 times or until fuel is visible in the line.
4. Pull the starter cord slowly until resistance is felt. Then give the recoil starter cord a few short, brisk pulls until the engine fires.
5. If engine fails to start in 4 pulls, use "Cold" starting procedure
6. With engine running, and both hands on the handles, squeeze throttle trigger gradually to increase the engine speed and engage the tines.

Stopping the Engine

Simply move the engine switch to "STOP" position. This will stop the engine instantly. If it should ever fail to do so, just slide the choke lever to "START" to stall the engine.

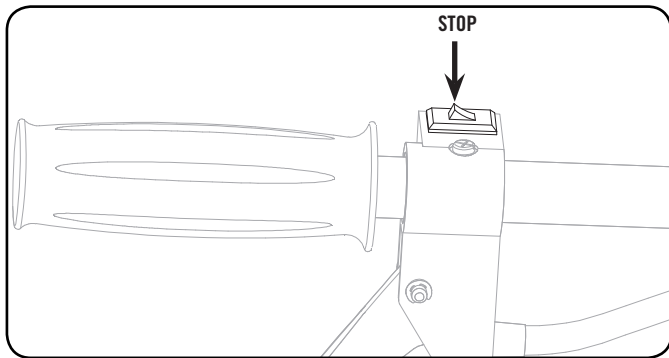

Special Feature (with Idle Set Properly and the Engine Running).

Even when the engine is running, the tines won't turn unless you press the throttle lever on the handlebars. And, when you release the throttle lever, the tines will stop.

Tips for Extending Engine Life

After you start the engine, let your cultivator warm up for two to three minutes before you use it. Then, before you put your cultivator away, let it idle for a minute to give the engine a chance to cool down.

Always shake mixed fuel before adding to the cultivator to ensure proper oil content.

Only use fuel less than 60 days old.

Tips for Extending Engine Life Cont'd.

! WARNING

If the engine does not stop when the engine switch is moved in the "STOP" position, release the throttle. Allow the engine to idle.

Put the cultivator down and slide the choke lever to cold start (closed) position.

Check and return engine switch to the "ON" position before starting the engine again.

Cultivating

Now You're ready to Use Your Cultivator

If you've used a cultivator in the past you know that you walk behind a cultivator as the soil is churned. Your Champion cultivator may surprise you in the fact it works best if you pull it towards you. It tills best when you pull it backward! You see, when you pull your cultivator backward, it provides extra resistance to the tines, so they dig deeper. What's more when you go backward, you create a soil bed that stays light and fluffy ready for plating.

Place your cultivator at the head of the row or area you want to cultivate. Start it up. Then use an easy rocking motion to pull your cultivator backward and then, let it move forward. Repeating this motion while moving the cultivator left and right will maximize the performance of the product and produce optimum planting conditions by helping you cultivate deeper.

Keep repeating these steps until you've tilled an entire row. Start again on the next row. It's much like running a vacuum cleaner!

You Can Even Control Depth

For Deeper Cultivating:

Move your cultivator slowly back and forth, as you would a vacuum cleaner. Work the same area over and over until you've dug to your desired depth.

You can use your transport wheel / depth gauge assembly to set specific working depth for your cultivator, see the diagram.

For Shallow Cultivating and Weeding:

You can quickly skim over an area to weed or scarify the ground for seeding. Simply move the cultivator quickly over your soil surface back and forth, left and right allowing the tines to float on the top of the ground.

OPERATION

You Can Even Control Depth Cont'd.

For Big Weeds or Tough Roots:

Let your cultivator rock back and forth over the tough spot, until the tines slice through the weed or root.

DANGER

The operator of this cultivator is responsible for accidents or hazards occurring to himself, other people or their property.

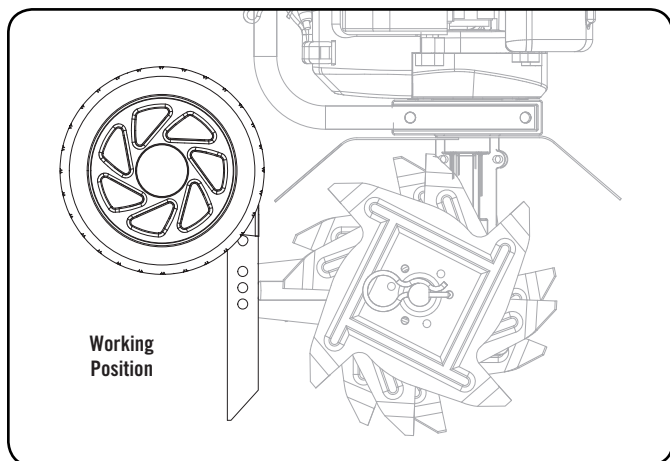
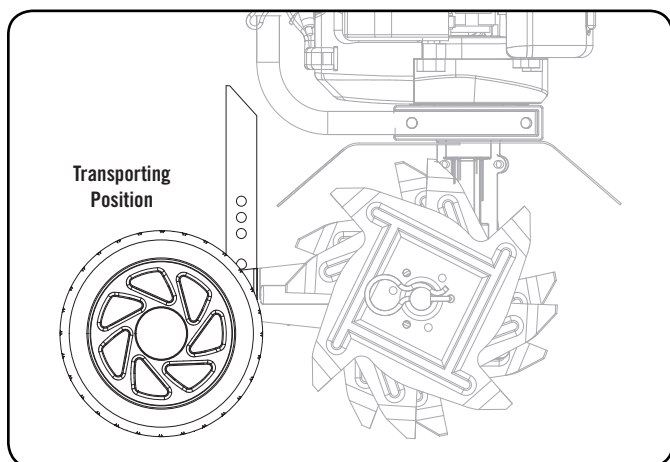
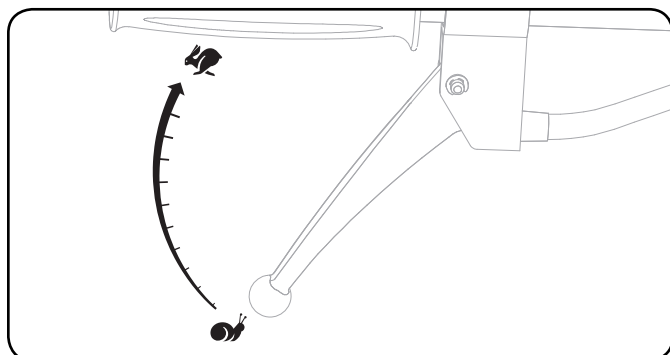

You Can Even Control Depth Cont'd.

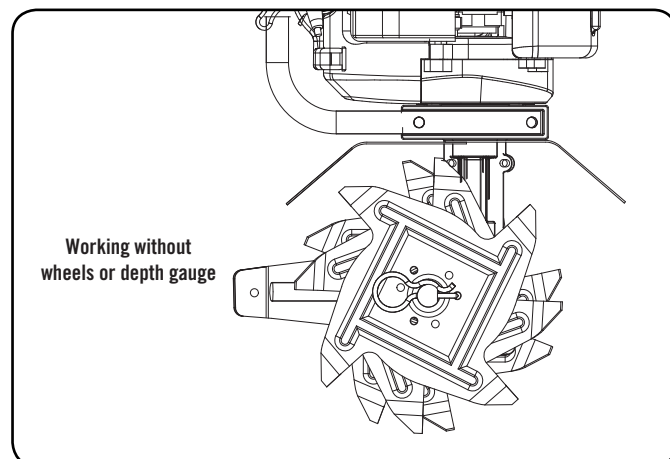

Remember, any cultivator will tangle in tall grass, stringy vines, or overly large weeds. So, if you plan to cultivate in these conditions first use a pruner or brush cutter to chop up the overgrowth. If the tines become tangled, turn the engine off and allow the tines to full come to a stop before trying to clear them.

WARNING

If your tines get jammed or entangled, shut off the engine at once.

Remove the obstruction while the engine is off.

NEVER try to remove an obstruction while the engine is running. **SERIOUS INJURY CAN RESULT.**

Cultivator Maintenance

How to Check, Clean and Change the Air Filter

Check the air filter every 25 hours of use or more frequently if used under dusty conditions. A clogged air filter may increase fuel consumption while cutting down the engine power. Never operate the cultivator without the air filter or with a deformed filter element because unfiltered dusty air will quickly ruin the engine.

Cleaning Air Filter

1. Remove the air cleaner cover by pulling the tab on side and take out the filter element.
2. Use mild detergent and warm water to clean the filter element. After cleaning, air dry the element completely and moisten with a small amount of motor oil.
3. Place the filter element into the air cleaner housing and press the cover against the housing until it clicks.

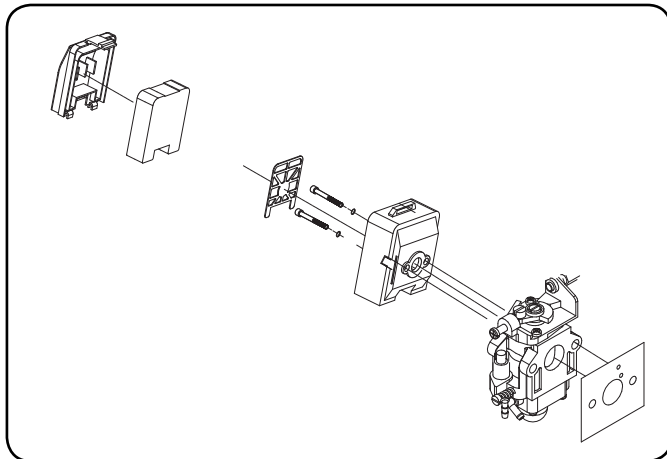

Idle Speed Adjustment

1. Warm up engine before adjusting idle speed.
2. The idle speed adjustment screw controls the throttle opening at idle position.
3. When the engine tends to stop frequently at idling mode, turn the adjusting screw clock wise.
4. If the tines continue to rotate after releasing the trigger, turn the adjusting screw counter-clockwise.

Clear Blockages From the Fuel Line & Filter

1. After you've used your cultivator for a few seasons, check for blockages in the fuel tank and fuel filter. Such blockages can keep your cultivator from starting and running properly.
2. Clear any blockages you see in the tank or fuel line, replace the fuel filter if needed.

Clear Blockages From the Fuel Line & Filter Cont'd.

NOTE

The fuel filter is located inside the tank.

Spark Plug

1. Starting failure and mis-firing are often caused by a fouled spark plug. Clean the spark plug and check the that the plug gap is in the correct range, replace the plug if necessary (0.5 - 0.7 mm {0.020 - 0.028 in.}).
2. To install the spark plug first turn the plug until it is finger tight, then tighten it a quarter turn more with a socket wrench (19 mm).

CAUTION

DO NOT overtighten the spark plug.

NOTE

The cultivator uses NHSP L8RTC or NGK BPMR7A spark plug. Use an exact replacement and replace annually.

Muffler

- Inspect periodically the muffler for loose fasteners, any damage or corrosion or blockage caused by insect nests. If any sign of exhaust leakage is found, stop using the machine and have it repaired immediately.

WARNING

Note that failing to do so may result in the engine catching on fire.

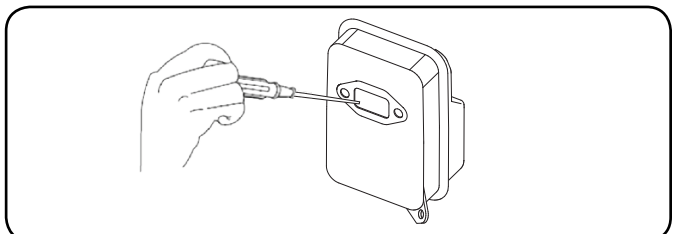
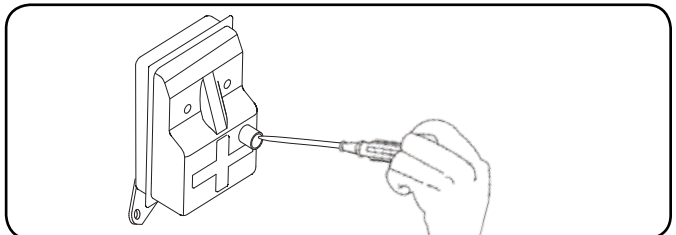

MAINTENANCE AND STORAGE

Intake Air Cooling Vent

- Never touch the cylinder, muffler, or spark plugs with your bare hands immediately after stopping the engine. The engine can become very hot when in operation, and doing so could result in severe burns.
- When checking the machine before using it, check the area around the muffler and remove any debris. Failing to do so could cause the muffler to become overheated, and that this in turn could cause the engine to catch on fire. Always make sure that the muffler is clean and free of debris before use.
- Check the intake air cooling vent and the area around the cylinder cooling fins after every 25 hours of use for blockage. Note that it is necessary to remove the engine cover in order to view the upper part of the cylinder.

Procedures to be Performed After Every 100 Hours of Use

1. Remove the muffler, insert a screwdriver into the vent, and wipe away any carbon buildup. Wipe away any carbon buildup on the muffler exhaust vent and cylinder exhaust port at the same time.
2. Tighten all screws, bolts, and fittings.
3. Check to see if any oil or grease has worked its way in between the clutch lining and drum, and if it has, wipe it away using oil-free, lead-free gasoline.

Maintenance Schedule

Follow the service intervals indicated in the schedule below. Service your cultivator more frequently when operating in adverse conditions. Contact our help line at **1-877-338-0999** to locate the nearest Champion Power Equipment authorized service dealer for your cultivator or engine maintenance needs.

Before use	
	Wipe out fuel leaks, fuel spillage.
	Inspect and clean fuel tank, air filter and fuel filter.
Every 25 hours	
	Clean cylinder fins and intake air cooling vent.
Every 50 hours	
	Clean and readjust spark plug gap (gap: 0.5 - 0.7 mm {0.020 - 0.028 in.} replace if necessary).
	Clean exhaust port.
Annually	
	Replace spark plug.

Time intervals shown are maximum. Actual use and your experience will determine the frequency of required maintenance.

Cultivator Storage

Each fall — or before you store your cultivator for any long period — be sure to take these measures:

1. Do not store your cultivator with fuel still in it. Even under ideal conditions, stored fuel containing ethanol or MTBE can start to go stale in as little as 30 days. Since stale fuel has a high gum content, it can clog the carburetor, this, will in turn restrict fuel flow. So, when you're ready to store your cultivator, or will not be using it for more than 2 weeks, drain the fuel tank completely.

NOTE

You can store the unit with 50:1 TruFuel because it is pretreated with stabilizer and has NO ethanol content.

2. Remove fuel from the carburetor and fuel lines by starting the engine and letting the cultivator run out of fuel. This will prevent gum deposits forming inside of the carburetor and possible engine damage.
3. Disconnect spark plug wire and remove the spark plug (use a 19 mm spark-plug wrench). Pour about a teaspoon of clean, air-cooled, two cycle oil through the spark-plug hole into the combustion chamber. Slowly pull the starter cord two or three times to coat the inside of the cylinder wall.
4. Inspect the spark plug, and, if necessary, clean it. The cultivator uses NHSP L8RTC or NGK BPMR7A spark plug. Use an exact replacement and replace annually.
5. Install the spark plug, but leave the spark plug wire disconnected.
6. Clean the air filter as described on page 14.
7. Clean dirt, grass, and other materials from the entire machine.
8. Wipe the tines with oil or spray them with WD-40, to prevent rusting.
9. Oil the throttle cable and all visible moving parts. (Do not remove the engine cover.)
10. Store your cultivator — in an upright position — in a clean, dry place.
11. Do you have fuel left over from last season? Dispose of it properly. Buy fresh oil and gasoline next season.

How to Prepare Your Cultivator for Restarting

In the Spring, when you take your cultivator out of storage, remove the spark plug. Pull the starter cord three or four times to clean oil from the combustion chamber. Wipe oil from the spark plug. Place the spark plug back into the cylinder. Reconnect the spark plug wire back on the spark plug. Then follow the steps to refuel and restart your cultivator.

Re-Starting problems after storage

If your cultivator won't restart in the Spring - or if it lacks its usual power - the carburetor may need attention or the spark plug may be at fault. Check to see if the plug is fouled with oily black deposits. Clean or replace it if it is.

Also, check whether the center electrode is rounded at the end, or if the ground electrode is worn. If either is the case, you should replace it with a NHSP L8RTC or NGK BPMR7A spark plug. Use a 19 mm spark-plug wrench to install it. Adjust the plug gap to 0.5 - 0.7 mm (0.020 - 0.028 in.). To install the spark plug first turn the plug until it is finger tight, then tighten it a quarter turn more with a socket wrench.

NOTE

To avoid possible damage to the threads, do not try to remove the plug from a hot aluminum cylinder head.

TROUBLESHOOTING

Starting Problems

If you follow the normal starting procedure, you should have no problem starting your cultivator. But, just in case you do have problems, here's what to do:

1. Make sure the engine switch is in the "ON" position. If the switch was in the "STOP" position when you pulled the cord, you may have flooded the engine. Even if the engine switch is in the "ON" position, it is possible to flood the engine. The smell of fuel can be a sign the engine is flooded.

a. Flooded Engine Procedure:

- i. First, examine the spark plug. Use a 19 mm spark plug wrench.
- ii. Remove the cap over the spark plug.

IMPORTANT

To avoid possible damage to the threads, do not try to remove the plug from a hot engine.

- iii. Unscrew the spark plug.
 - iv. If the end of the spark plug is wet, the engine may be flooded. Make sure the switch is in the "Stop" position, disconnect spark plug wire and remove plug. Use a paper towel or a clean rag to dry the spark plug, then, with the spark plug out of the engine, pull the starter cord several times. Shake the fuel out of the inside of the plug and air dry. Next, replace the spark plug. Use the wrench to tighten it and replace the cap. Next, put the switch in the "Start" position and pull the choke lever into the "Start" position. Pull the starter cord three or four times until the engine coughs or sputters. Open the choke (move the choke lever to the "Run" position) and pull the cord a few times. The engine should start and run.
2. If the end of the spark plug is dry, check to see if the fuel line is blocked. The fuel line runs from the fuel tank to the carburetor. Pull it off at the carburetor end. Fuel should drip slowly from the line. Wipe off any excess or spilled fuel.
If fuel does not drip from the line, check the line for any bends or pinches. Kinks in the line restrict the flow of fuel to the engine. Just straighten out the line. Reconnect. Then follow the normal starting procedure.

Starting Problems Cont'd

If fuel drips too freely, the line may be disconnected from the fuel filter. You'll find the fuel filter inside the fuel tank. Just re-attach the line to the filter, and put the filter back in the tank. Then follow the normal starting procedure.

WARNING

Make sure the engine switch is in the top position. Keep plug wire away from engine to avoid unintentional spark.

IMPORTANT

Never use starting fluids. Starting fluids will cause permanent engine damage. Using them will void the warranty.

Problem	Check	Cause	Solution
Starting Failure	Fuel tank	Incorrect fuel	Drain and fill with correct fuel
	Fuel filter	Fuel filter is clogged	Replace fuel filter
	Flooded engine	Multiple	Let unit sit to air out (15 minutes) or remove spark plug and clean per instruction in manual
	Sparking (no spark)	Spark plug is fouled/ wet, plug gap is incorrect	Clean/ dry, correct gap: 0.5 - 0.7 mm (0.020 - 0.028 in.)
Engine starts but does not keep running/ hard re-starting	Fuel Tank	Incorrect fuel	Drain and fill with correct fuel
	Muffler, cylinder (exhaust port)	Carbon is built-up or insect nest in exhaust port	Wipe away and or clean out
	Air cleaner	Clogged with dust	Wash with mild detergent and water, dry thoroughly

For further technical support:**Technical Service**

Mon – Fri 8:30 AM – 5:00 PM (PST/PDT)

Toll Free: 1-877-338-0999

tech@championpowerequipment.com

SPECIFICATIONS**Engine Specifications**

- Model 1E40F-2E
- Displacement 43cc
- Type 2-Stroke
- Start Type Recoil

Cultivator Specifications

- Fuel/Oil Ratio 50:1
- Fuel Capacity 0.3 gal. (1.1 L)
- Gross Weight 43.4 lb. (19.7 kg)
- Net Weight 36.4 lb. (16.5 kg)
- Height 38.6 in. (98 cm)
- Width 18.9 in. (48 cm)
- Length 30.3 in. (77 cm)

Spark Plugs**OEM spark plug:** NHSP L8RTC**Replacement spark plug:** NGK BPMR7A or equivalent.

Make certain the spark plug gap is 0.5 - 0.7 mm (0.020 - 0.028 in.)

SPECIFICATIONS

Parts Diagram

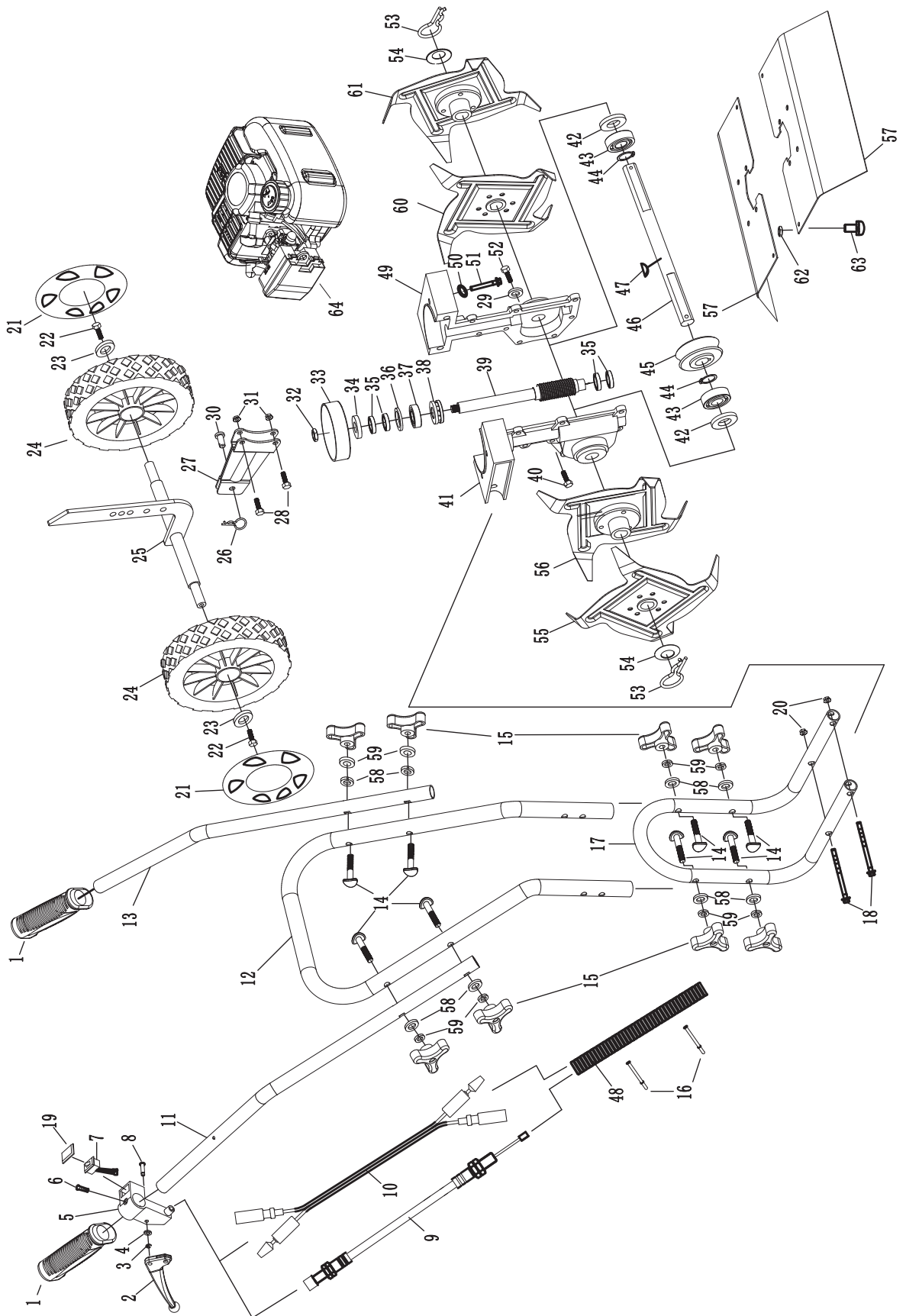

#	Part Number	Description	Qty
1	711.200702.00	Cover, Handle	2
2	711.324010.00	Throttle Lever	1
3	1.896.035	Circlip Ø3.5	1
4	1.971.05	Washer Ø5	1
5	711.324020.00	Throttle Bracket	1
6	1.15865.1.4819	Screw ST4.8 x 19	1
7	5.1010.005	Switch Assembly	1
8	711.324030.00	Pin	1
9	711.324040.00	Throttle Cable Assembly	1
10	100378.21.10	Connector Wire	1
11	711.321010.00	Right Handle	1
12	711.321020.00	Middle Handle	1
13	711.321030.00	Left Handle	1
14	2.08.084	Capscrew M8 x 45	8
15	2.02.035	Knob-Handle M8	8
16	2.99.002	Tie Strap	2
17	711.321040.00	Lower Handle	1
18	1.5789.08150.1	Bolt M8 x 150	2
19	5.1010.005.00	Waterproof Cover, Switch	1
20	1.6187.1.08.1	Lock Nut M8	2
21	711.323012.00	Wheel Cap	2
22	1.29.2.0612.1	Screw M6 x 12	2
23	1.96.06.1	Washer Ø6	2
24	711.323011.00	Wheel Assembly	2
25	711.323020.00	Axle Assembly	1
26	2.16.003	Pin Ø3 , "R" Shape	1
27	711.323030.00	Bracket Assembly	1
28	1.5786.0630	Bolt M6 x 30	2
29	1.971.06	Sealing Washer Ø6	2
30	711.323040.00	Clevis Pin 8 x 18	1
31	1.6187.1.06	Lock Nut M6	2
32	1.6172.1.10	Nut M10	1
33	711.322001.00	Clutch Drum	1
34	711.322002.00	Big Bushing, Cuprum	1
35	711.322008.00	Roller Bearing 61802-2RZ	4
36	711.322004.00	Washer	1
37	711.322005.00	Roller Bearing 6002-2RS	1
38	711.322006.00	Worm Thrust Bearing 51202	1
39	711.322009.00	Worm Shaft	1
40	1.9074.13.0618	Bolt M6 x 18	6
41	711.322013.00	Left Gear Housing	1
42	711.322015.00	Seal, Bearing	2
43	711.322007.00	Turbine Bearing 6203-2RS	2
44	1.894.1.20	Snapping	2
45	711.322011.00	Turbine	1
46	711.322012.00	Transmission Shaft	1
47	2.14.016	Key 5 x 6.5 x 16	1

#	Part Number	Description	Qty
48	5.1330.114	Housing, Throttle Cable & Connector Wire	1
49	711.322014.00	Right Gear Housing	1
50	1.93.06	Lock Washer Ø6	4
51	1.5789.0640.1	Bolt M6 x 40	4
52	1.9074.13.0610	Bolt/Washer Assembly M6 x 10	2
53	2.16.004	Pin, "R" Shape	2
54	2.03.059	Butterfly Type Washer Ø20	2
55	711.325010.05	Tine Assembly, D	1
56	711.325010.04	Tine Assembly, C	1
57	711.321050.00.48	Fender Guard, Yellow	2
58	1.971.1.08	Washer Ø8	8
59	1.93.08	Lock Washer Ø8	8
60	711.325010.03	Tine Assembly, B	1
61	711.325010.02	Tine Assembly, A	1
62	1.6170.05	Lock Nut M5	2
63	1.9074.13.0510	Bolt M5 x 10	2
64	3WG430.7	Engine	1

SPECIFICATIONS

Engine Parts Diagram

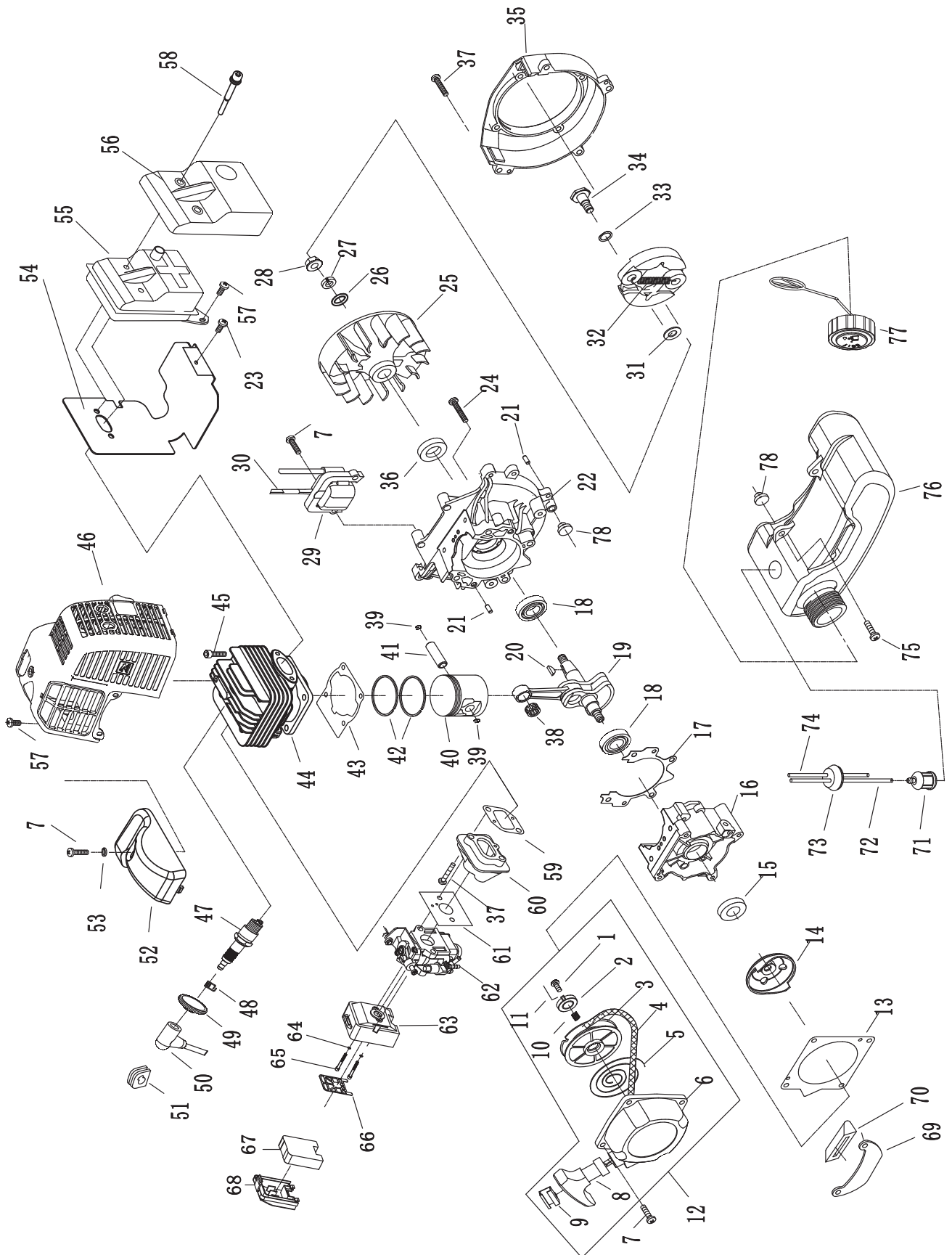

#	Part Number	Description	Qty
1	1E36FE.9-3	Screw	1
2	1E36FE.9-4	Ratchet	1
3	1E36FE.9-1	Starter Rope Reel	1
4	1E36FE.9-5	Starter Rope	1
5	1E36FE.9-7	Recoil Spring	1
6	1E36FE.9-8	Starter Cover Assembly	1
7	GB70+GB93+GB97	Screw M5 x 20	5
8	CG520-HL.5-1	Start Handle	1
9	1E40FP-3Z.4-10	Hodler, Rope	1
10	1E36FE.9-6	Spring	1
11	1E36FE.9-2	Start pole	2
12	CG520-HL.5	Starter Assembly	1
13	1E40F-5-10	Gasket, Starter	1
14	1E36FE.7	Start Reel	1
15	1E36F.2	Oil Seal	1
16	1E40F-E.6-2	Crankcase, Rear	1
17	1E40F-5.8-4	Gasket, Crankcase	1
18	GB/T276	Bearing 6202/P6	2
19	1E40F-E.4.1A	Crankshaft/Connecting Rod Assembly	1
20	GB1099	Key 3 x 5 x 13	1
21	GB119	Pin 4h8 x 10	4
22	1E40F-E.6-1	Crankcase, Front	1
23	GB70+GB93+GB97	Screw M4 x 12	1
24	GB/T70.1	Screw M5 x 30	4
25	HA46.2.1.1	Fan, Engine	1
26	GB/T97.1	Washer Ø8	1
27	GB/T859	Lock Washer Ø8	1
28	GB6170	Nut M8	1
29	1E40F-E.3.1-2	Ignition Coil Component	1
30	1E36F-2.3.1	Cord Component	1
31	1E36F-3	Flat Washer B	2
32	1E40F-5.6C	Expander	1
33	1E40F-5-11	Wave Spring Washer	2
34	P40-18	Screw Pin	2
35	1E40F-5-9	Fan Cover	1
36	1E40F-5.9	Oil Seal	1
37	GB70+GB93+GB97	Screw M5 x 25	2
38	1E44F-2A.2-3	Bearing	1
39	P40.6-4	Circlip, Piston Pin	2
40	1E40F-E.4-1	Piston	1
41	1E46FP.6-3	Piston Pin	1
42	1E40FP-3Z.3-5	Piston Ring Assembly	1
43	1E40F-E-3	Gasket, Cylinder	1
44	1E40F-2E-1	Cylinder	1
45	GB/T70.1	Screw M5 x 20	4
46	1E44FL-E.1A	Guide Cover Assembly	1
47	L8RTC	Spark Plug L8RTC	1
48	1E40F-3A.8-2	Spring, Spark Plug	1
49	1E34F.5-3	Spark Plug Cap	1
50	1E34F.5-2	Cap	1

#	Part Number	Description	Qty
51	1E40F-5.3-1A	Plug	1
52	1E40F-E-4	Top Cover	1
53	1E36F-2C-1	Insulation Gasket	1
54	1E40F-E-2	Gasket, Muffler	1
55	1E40F-2E-DZ.2A	Muffler Assembly	1
56	1E40F-2E-DZ-1	Cover, Muffler	1
57	GB70+GB93+GB97	Screw M5 x 12	2
58	GB70+GB97	Screw M6 x 60-12.9	2
59	1E40-5-2	Gasket, Admitting Pipe	1
60	1E44F-E-PBJ.7	Admitting Pipe	1
61	1E40-5A-1	Gasket, Carburetor	1
62	1E40F-2E.1A	Carburetor Assembly	1
63	3WG430.7.2.1	Air Cleaner Housing	1
64	GB/T97.1	Washer Ø5	2
65	GB/T70.1	Bolt M5 x 55	2
66	3WG430.7.2-5	Plate, Filter	1
67	MC25.9-1	Filter	2
68	3WG430.7.2-1	Air Cleaner Cover	1
69	1E36F-E-5	Stand, Fuel Tank	1
70	1E40F-5A-2	Rubber Cover	1
71	P40.12.2-3A	Fuel Filter	1
72	1E44F-E.5.1-1A-EPA	Fuel Inlet Pipe	1
73	1E36FF.8.1-1	Seal Plug	1
74	1E44F-E.5.1-2-EPA	Fuel Return Pipe	1
75	GB70.1+GB93+GB96	Screw M5 x 16	2
76	1E40F-2E-YF.1-1	Fuel Tank	1
77	1E40F-2E-YF.1.1	Fuel Tank Cap Assembly	1
78	1E40F-5A-3	Rubber washer	2

WARRANTY

WARRANTY*

CHAMPION POWER EQUIPMENT
2 YEAR LIMITED WARRANTY

Warranty Qualifications

Champion Power Equipment (CPE) will register this warranty upon receipt of your Warranty Registration Card and a copy of your sales receipt from one of CPE's retail locations as proof of purchase.

Please submit your warranty registration and your proof of purchase within ten (10) days of the date of purchase.

Repair/Replacement Warranty

CPE warrants to the original purchaser that the mechanical and electrical components will be free of defects in material and workmanship for a period of two years (parts and labor) from the original date of purchase. Transportation charges on product submitted for repair or replacement under this warranty are the sole responsibility of the purchaser. This warranty only applies to the original purchaser and is not transferable.

Do Not Return The Unit To The Place Of Purchase

Contact CPE's Technical Service and CPE will troubleshoot any issue via phone or e-mail. If the problem is not corrected by this method, CPE will, at its option, authorize evaluation, repair or replacement of the defective part or component at a CPE Service Center. CPE will provide you with a case number for warranty service. Please keep it for future reference. Repairs or replacements without prior authorization, or at an unauthorized repair facility, will not be covered by this warranty.

Warranty Exclusions

This warranty does not cover the following repairs and equipment:

Normal Wear

Products with mechanical and electrical components need periodic parts and service to perform well. This warranty does not cover repair when normal use has exhausted the life of a part or the equipment as a whole.

This limited warranty does not cover the cases:

- 1) Tune-ups - Spark Plugs, Carburetor Adjustments or Filters
- 2) Normal Wear items like Starter Ropes and Pulleys, Fuel Lines, Fuel Filters, Air Filters and Cultivator Tines

Installation, Use and Maintenance

This warranty will not apply to parts and/or labor if the product is deemed to have been misused, neglected, involved in an accident, abused, loaded beyond the product's limits, modified, installed improperly or connected incorrectly to any electrical component. Normal maintenance is not covered by this warranty and is not required to be performed at a facility or by a person authorized by CPE.

Other Exclusions

This warranty excludes:

- Cosmetic defects such as paint, decals, etc.
- Wear items such as filter elements, o-rings, etc.
- Accessory parts such as starting batteries, and storage covers.
- Failures due to acts of God and other force majeure events beyond the manufacturer's control.
- Problems caused by parts that are not original Champion Power Equipment parts.

When applicable, this warranty does not apply to products used for prime power in place of a utility.

Limits of Implied Warranty and Consequential Damage

Champion Power Equipment disclaims any obligation to cover any loss of time, use of this product, freight, or any incidental or consequential claim by anyone from using this product. THIS WARRANTY AND THE ATTACHED U.S. EPA, CARB and/or ECCC EMISSION CONTROL SYSTEM WARRANTIES (WHEN APPLICABLE) ARE IN LIEU OF ALL OTHER WARRANTIES, EXPRESS OR IMPLIED, INCLUDING WARRANTIES OF MERCHANTABILITY OR FITNESS FOR A PARTICULAR PURPOSE.

A unit provided as an exchange will be subject to the warranty of the original unit. The length of the warranty governing the exchanged unit will remain calculated by reference to the purchase date of the original unit.

This warranty gives you certain legal rights which may change from state to state or province to province. Your state or province may also have other rights you may be entitled to that are not listed within this warranty.

Contact Information

Address

Champion Power Equipment, Inc.
Customer Service
12039 Smith Ave.
Santa Fe Springs, CA 90670 USA
www.championpowerequipment.com

Customer Service

Mon – Fri 8:30 AM – 5:00 PM (PST/PDT)
Toll Free: 1-877-338-0999
info@championpowerequipment.com
Fax no.: 1-562-236-9429

Technical Service

Mon – Fri 8:30 AM – 5:00 PM (PST/PDT)
Toll Free: 1-877-338-0999
tech@championpowerequipment.com
24/7 Tech Support: 1-562-204-1188

*Except as otherwise stipulated in any of the following enclosed Emission Control System Warranties (when applicable) for the Emission Control System: U.S. Environment Protection Agency (EPA), California Air Resources Board (CARB) and/or Environment and Climate Change Canada (ECCC).

**Champion Power Equipment, Inc. (CPE),
United States Environment Protection Agency (U.S. EPA)
Emission Control System Warranty**

Your Champion Power Equipment (CPE) engine complies with U.S. EPA emission regulations.

YOUR WARRANTY RIGHTS AND OBLIGATIONS:

The US EPA AND CPE are pleased to explain the Federal Emission Control Systems Warranty on your 2017 small off-road engine and engine powered equipment. New engines and equipment must be designed, built and equipped, at the time of sale, to meet U.S. EPA regulations for small non-road engines. CPE warrants the emission control system on your small off-road engine and equipment for the period of time listed below, provided there has been no abuse, neglect, unapproved modification, or improper maintenance of your equipment.

Your emission control system may include parts such as the carburetor, fuel-injection system, the ignition system, catalytic converter and fuel lines. Also included may be hoses, belts, connectors and other emission related assemblies. Where a warrantable condition exists, CPE will repair your small off-road engine at no cost to you including diagnosis, parts and labor.

MANUFACTURER'S EMISSION CONTROL SYSTEM WARRANTY COVERAGE:

This emission control system is warranted for two years, subject to provisions set forth below. If, during the warranty period, emission related part on your engine is defective in materials or workmanship, the part will be repaired or replaced by CPE.

OWNER WARRANTY RESPONSIBILITIES:

As the small off-road engine owner, you are responsible for the performance of the required maintenance listed in your Owner's Manual. CPE recommends that you retain all your receipts covering maintenance on your small off-road engine, but CPE cannot deny warranty solely for the lack of receipts or for your failure to ensure the performance of all scheduled maintenance.

As the small off-road engine owner, you should however be aware that CPE may deny you warranty coverage if your small, off-road engine or a part has failed due to abuse, neglect, improper maintenance or unapproved modifications.

You are responsible for presenting your small off-road engine to an Authorized CPE service outlet or alternate service outlet as described in (3)(f.) below, CPE dealer or CPE, Santa Fe Springs, Ca. as soon as a problem exists. The warranty repairs should be completed in a reasonable amount of time, not to exceed 30 days.

If you have any questions regarding your warranty rights and responsibilities, you should contact:

Champion Power Equipment, Inc.
Customer Service
12039 Smith Ave.
Santa Fe Springs, CA 90670
1-877-338-0999
tech@championpowerequipment.com

EMISSION CONTROL SYSTEM WARRANTY

The following are specific provisions relative to your Emission Control System (ECS) Warranty Coverage.

1. APPLICABILITY: This warranty shall apply to 1997 and later model year small off-road engines. The ECS Warranty Period shall begin on the date the new engine or equipment is delivered to its original, end-use purchaser, and shall continue for 24 consecutive months thereafter.

2. GENERAL EMISSIONS WARRANTY COVERAGE

CPE warrants to the original, end-use purchaser of the new engine or equipment and to each subsequent purchaser that each of its small off-road engines is:

- a. Designed, built and equipped so as to conform to U.S. EPA emissions standards for spark-ignited engines at or below 19 kilowatts.
- b. Free from defects in materials and workmanship that cause the failure of a warranted part to be identical in all material respects to the part as described in the engine manufacturer's application for certification for a period of two years.

3. THE WARRANTY ON EMISSION-RELATED PARTS WILL BE INTERPRETED AS FOLLOWS:

a. Any warranted part that is not scheduled for replacement as required maintenance in the Owners Manual shall be warranted for the ECS Warranty Period. If any such part fails during the ECS Warranty Period, it shall be repaired or replaced by CPE according to Subsection "d" below. Any such part repaired or replaced under the ECS Warranty shall be warranted for any remainder of the ECS Warranty Period.

b. Any warranted, emissions-related part which is scheduled only for regular inspection as specified in the Owners Manual shall be warranted for the ECS Warranty Period. A statement in such written instructions to the effect of "repair or replace as necessary", shall not reduce the ECS Warranty Period. Any such part repaired or replaced under the ECS Warranty shall be warranted for the remainder of the ECS Warranty Period.

c. Any warranted, emissions-related part which is scheduled for replacement as required maintenance in the Owner's Manual shall be warranted for the period of time prior to the first scheduled replacement point for that part. If the part fails prior to the first scheduled replacement, the part shall be repaired or replaced by CPE according to Subsection "d" below. Any such emissions-related part repaired or replaced under the ECS Warranty, shall be warranted for the remainder of the ECS Warranty Period prior to the first scheduled replacement point for such emissions-related part.

d. Repair or replacement of any warranted, emissions-related part under this ECS Warranty shall be performed at no charge to the owner at a CPE Authorized Service Outlet.

e. The owner shall not be charged for diagnostic labor which leads to the determination that a part covered by the ECS Warranty is in fact defective, provided that such diagnostic work is performed at a CPE Authorized Service Outlet.

f. CPE shall pay for covered emissions warranty repairs at non-authorized service outlets under the following circumstances:

i. The service is required in a population center with a population over 100,000 according to U.S. Census 2000 without a CPE Authorized Service Outlet AND

ii. The service is required more than 100 miles from a CPE Authorized Service Outlet. The 100 mile limitation does not apply in the following states: Alaska, Arizona, Colorado, Hawaii, Idaho, Montana, Nebraska, Nevada, New Mexico, Oregon, Texas, Utah and Wyoming.

g. CPE shall be liable for damages to other original engine components or approved modifications proximately caused by a failure under warranty of an emission-related part covered by the ECS Warranty.

h. Throughout the ECS Warranty Period, CPE shall maintain a supply of warranted emission-related parts sufficient to meet the expected demand for such emission-related parts.

i. Any CPE Authorized and approved emission-related replacement part may be used in the performance of any ECS Warranty maintenance or repair and will be provided without charge to the owner. Such use shall not reduce CPE's warranty obligation.

j. Unapproved add-on or modified parts may not be used to modify or repair a CPE engine. Such use voids this ECS Warranty and shall be sufficient grounds for disallowing an ECS Warranty claim. CPE shall not be liable hereunder for failures of any warranted parts of a CPE engine caused by the use of such an unapproved add-on or modified part.

EMISSION-RELATED PARTS INCLUDE THE FOLLOWING: (using those portions of the list applicable to the engine)

Systems covered by this warranty	Parts Description
Fuel Metering System	Fuel regulator, Carburetor and internal parts
Air Induction System	Air cleaner, Intake manifold
Ignition System	Spark plug and parts, Magneto ignition system
Exhaust System	Exhaust manifold, catalytic converter
Miscellaneous Parts	Tubing, Fittings, Seals, Gaskets, and Clamps associated with these listed systems.
Evaporative Emissions	Fuel Tank, Fuel Cap, Fuel Line, Fuel Line Fittings, Clamps, Pressure Relief Valves, Control Valves, Control Solenoids, Electronic Controls, Vacuum Control Diaphragms, Control Cables, Control Linkages, Purge Valves, Vapor Hoses, Liquid/Vapor Separator, Carbon Canister, Canister Mounting Brackets, Carburetor Purge Port Connector

TO OBTAIN WARRANTY SERVICE:

You must take your CPE engine or the product on which it is installed, along with your warranty registration card or other proof of original purchase date, at your expense, to any Champion Power Equipment dealer who is authorized by Champion Power Equipment, Inc. to sell and service that CPE product during his normal business hours. Alternate service locations defined in Section (3)(f.) above must be approved by CPE prior to service. Claims for repair or adjustment found to be caused solely by defects in material or workmanship will not be denied because the engine was not properly maintained and used.

If you have any questions regarding your warranty rights and responsibilities, or to obtain warranty service, please write or call Customer Service at Champion Power Equipment, Inc.

**Champion Power Equipment, Inc.
12039 Smith Ave.
Santa Fe Springs, CA 90670
1-877-338-0999
Attn.: Customer Service
tech@championpowerequipment.com**

**Champion Power Equipment, Inc (CPE) and Environment and Climate Change Canada (ECCC)
Emission Control System Warranty**

Your Champion Power Equipment (CPE) engine complies with Environment and Climate Change Canada (ECCC) emission regulations.

YOUR WARRANTY RIGHTS AND OBLIGATIONS:

CPE is pleased to explain the Emission Control Systems Warranty on your 2017 small off-road engine. New engines must be designed, built and equipped, at the time of sale, to meet ECCC regulations for small non-road engines. CPE must warrant the emission control system on your small off-road engine for the period of time listed below, provided there has been no abuse, neglect, unapproved modification, or improper maintenance of your small off-road engine.

Your emission control system may include parts such as the carburetor, fuel-injection system, the ignition system, catalytic converter and fuel lines. Also included may be hoses, belts, connectors and other emission related assemblies. Where a warrantable condition exists, CPE will repair your small off-road engine at no cost to you including diagnosis, parts and labour.

MANUFACTURER'S EMISSION CONTROL SYSTEM WARRANTY COVERAGE:

This emission control system is warranted for two years, subject to provisions set forth below. If, during the warranty period, emission related part on your engine is defective in materials or workmanship, the part will be repaired or replaced by CPE.

OWNER WARRANTY RESPONSIBILITIES:

As the small off-road engine owner, you are responsible for the performance of the required maintenance listed in your Owner's Manual. CPE recommends that you retain all your receipts covering maintenance on your small off-road engine, but CPE cannot deny warranty solely for the lack of receipts or for your failure to ensure the performance of all scheduled maintenance.

As the small off-road engine owner, you should however be aware that CPE may deny you warranty coverage if your small, off-road engine or a part has failed due to abuse, neglect, improper maintenance or unapproved modifications.

You are responsible for presenting your small off-road engine to an Authorized CPE service outlet, CPE dealer or CPE, Santa Fe Springs, CA., USA as soon as a problem exists. The warranty repairs should be completed in a reasonable amount of time, not to exceed 30 days.

If you have any questions regarding your warranty rights and responsibilities, you should contact:

Champion Power Equipment, Inc.
Customer Service
12039 Smith Ave.
Santa Fe Springs, CA 90670
USA
Tel: 1-877-338-0999
tech@championpowerequipment.com

EMISSION CONTROL SYSTEM WARRANTY

The following are specific provisions relative to your Emission Control System Warranty Coverage.

Emission Control System Warranty (ECS Warranty):

1. APPLICABILITY: The ECS Warranty Period shall begin on the date the new engine or equipment is delivered to its original, end-use purchaser, and shall continue for 24 consecutive months thereafter.

2. GENERAL EMISSIONS WARRANTY COVERAGE

CPE warrants to the original, end-use purchaser of the new engine or equipment and to each subsequent purchaser that each of its small off-road engines is:

a. Designed, built and equipped so as to conform at the time of sale with applicable regulations under the Canadian Environmental Protection Act, 1999 (CEPA 1999).

b. Free from defects in materials and workmanship that cause the failure of a warranted part to be identical in all material respects to the part as described in the engine manufacturer's application for certification for a period of two years.

3. THE WARRANTY ON EMISSION-RELATED PARTS WILL BE INTERPRETED AS FOLLOWS:

a. Any warranted part that is not scheduled for replacement as required maintenance in the Owners Manual shall be warranted for the ECS Warranty Period. If any such part fails during the ECS Warranty Period, it shall be repaired or replaced by CPE according to Subsection "d" below. Any such part repaired or replaced under the ECS Warranty shall be warranted for any remainder of the ECS Warranty Period.

b. Any warranted, emissions-related part which is scheduled only for regular inspection as specified in the Owners Manual shall be warranted for the ECS Warranty Period. A statement in such written instructions to the effect of "repair or replace as necessary", shall not reduce the ECS Warranty Period. Any such part repaired or replaced under the ECS Warranty shall be warranted for the remainder of the ECS Warranty Period.

c. Any warranted, emissions-related part which is scheduled for replacement as required maintenance in the Owner's Manual shall be warranted for the period of time prior to the first scheduled replacement point for that part. If the part fails prior to the first scheduled replacement, the part shall be repaired or replaced by CPE according to Subsection "d" below. Any such emissions-related part repaired or replaced under the ECS Warranty, shall be warranted for the remainder of the ECS Warranty Period prior to the first scheduled replacement point for such emissions-related part.

d. Repair or replacement of any warranted, emissions-related part under this ECS Warranty shall be performed at no charge to the owner at a CPE Authorized Service Outlet.

e. The owner shall not be charged for diagnostic labour which leads to the determination that a part covered by the ECS Warranty is in fact defective, provided that such diagnostic work is performed at a CPE Authorized Service Outlet.

f. CPE shall be liable for damages to other original engine components or approved modifications proximately caused by a failure under warranty of an emission-related part covered by the ECS Warranty.

g. Throughout the ECS Warranty Period, CPE shall maintain a supply of warranted emission-related parts sufficient to meet the expected demand for such emission-related parts.

h. Any CPE Authorized and approved emission-related replacement part may be used in the performance of any ECS Warranty maintenance or repair and will be provided without charge to the owner. Such use shall not reduce CPE's warranty obligation.

i. Unapproved add-on or modified parts may not be used to modify or repair a CPE engine. Such use voids this ECS Warranty and shall be sufficient grounds for disallowing an ECS Warranty claim. CPE shall not be liable hereunder for failures of any warranted parts of a CPE engine caused by the use of such an unapproved add-on or modified part.

EMISSION-RELATED PARTS INCLUDE THE FOLLOWING: (using those portions of the list applicable to the engine)

Systems covered by this warranty	Parts description
Fuel Metering System	Fuel regulator, carburetor and internal parts
Air Induction System	Air cleaner, intake manifold
Ignition System	Spark plug and parts, magneto ignition system
Exhaust System	Exhaust manifold, catalytic converter
Miscellaneous Parts	Tubing, fittings, seals, gaskets, and clamps associated with these listed systems.
Evaporative Emissions	Fuel tank, fuel cap, fuel line, fuel line fittings, clamps, pressure relief valves, control valves, control solenoids, electronic controls, vacuum control diaphragms, control cables, control linkages, purge valves, vapour hoses, liquid/ vapour separator, carbon canister, canister mounting brackets, carburetor purge port connector

TO OBTAIN WARRANTY SERVICE:

You must take your CPE engine or the product on which it is installed, along with your warranty registration card or other proof of original purchase date, at your expense, to any Champion Power Equipment dealer who is authorized by Champion Power Equipment, Inc. to sell and service that CPE product during his normal business hours. Claims for repair or adjustment found to be caused solely by defects in material or workmanship will not be denied because the engine was not properly maintained and used.

If you have any questions regarding your warranty rights and responsibilities, or to obtain warranty service, please write or call Customer Service at Champion Power Equipment, Inc.

**Champion Power Equipment, Inc.
12039 Smith Ave.
Santa Fe Springs, CA 90670
USA
1-877-338-0999
Attn: Customer Service
tech@championpowerequipment.com**